



—
your partner
in sensor
technology.

+ Datasheet EE210

Humidity and Temperature Sensor
for Demanding Climate Control



EE210

Humidity and Temperature Sensor for Demanding Climate Control

The EE210 humidity (RH) and temperature (T) sensor is designed to meet the highest requirements in demanding climate control applications. Besides the accurate measurement of RH and T EE210 calculates various RH related parameters such as dew point temperature, absolute humidity and mixing ratio.

Outstanding Measurement Performance

Excellent performance of EE210 in polluted or aggressive environment is ensured by the encapsulated measurement electronics inside the sensing probe and the long-term stable E+E sensing element with proprietary coating.

Analogue, Digital Outputs and Display

All measured and calculated values are available on the RS485 interface with Modbus RTU protocol, two of them on the analogue voltage or current outputs, while up to three values can be shown simultaneously on the optional display.

Versatility

EE210 is available for wall or duct mount, with remote probe, as well as an outdoor version. The IP65/NEMA 4X enclosure minimizes installation costs and provides outstanding protection against contamination and condensation.

Easy Configuration and Adjustment

With an optional USB-C configuration stick, the user can set the RS485 interface parameters and output scaling, perform an offset or two point adjustment for RH and T and change display layout.



EE210 wall mount (type T1)



EE210 duct mount (type T2)



EE210 with remote probe (type T3)



EE210 outdoor with radiation shield (type T13)

Features

Display

- Selectable display layout
- Measurands freely selectable
- Backlight optional

Knockout for 1/2" conduit fitting (US)

External mounting holes

- Mounting with closed cover
- Electronics protected against construction site pollution
- Easy and fast mounting

Enclosure

- Protection rating IP65/NEMA 4X
- Type T13 compatible with radiation shield H010501

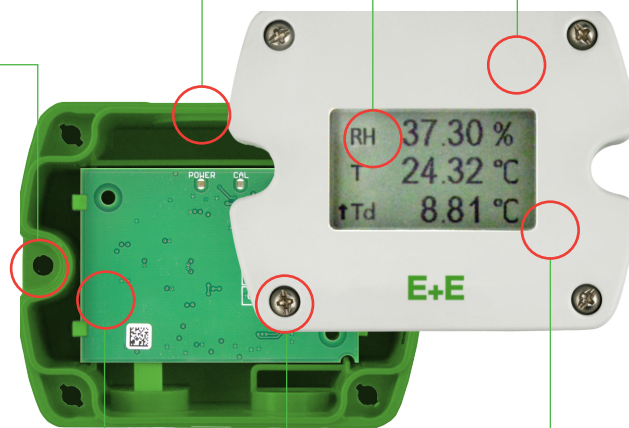

Electronics on the underside of the PCB

- Optimum protection against mechanical damage during installation

Smooth cover surface

- No accumulation of dust in protruding edges

Bayonet screws

- Open/close with a 1/4 rotation

Cast electronics

- Mechanical protection
- Condensation-resistant

E+E RH and T Sensing Element

- Outstanding long-term stability
- Protected solder pads
- Tested according to automotive standard AEC-Q200



Watertight cable outlet

Inspection certificate

according DIN EN 10204-3.1

Features

Protective Sensor Coating

The E+E proprietary sensor coating is a protective layer applied to the active surface of the sensing element. The coating substantially extends sensor lifetime and ensures optimal measurement performance in corrosive environment (salts, offshore applications). Additionally, it improves the sensors' long term stability in dusty, dirty or oily applications by preventing stray impedance caused by deposits on the active sensor surface.

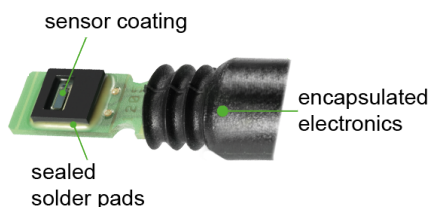

Accredited Traceable Calibration Certificate



Internationally recognised certificates for the calibration of measuring instruments from accredited laboratories document the traceability of the measurements to the International System of Units (SI). The E+E Elektronik calibration laboratory offers two levels of traceable calibrations.

- As a Designated Institute (DI) of the Republic of Austria, the E+E calibration laboratory maintains Austria's national measurement standards for humidity, dew point temperature, air velocity and CO₂. This authorises the E+E calibration laboratory to issue calibration certificates at the level of a National Metrological Institute (NMI).
- The E+E calibration laboratory is accredited by Akkreditierung Austria in accordance with DIN EN ISO/IEC 17025 with the identification number 0608. This allows the laboratory to issue ISO 17025 certificates for the measurands humidity, temperature, dew point temperature, air velocity, flow, pressure and CO₂.

Visit www.eplusecal.com for detailed information on calibration and to enquire a certificate of accredited traceable calibration for the EE210 from the Designated Institute.

ISO 9001 Calibration Certificate

An ISO 9001 calibration certificate documents the comparative measurement of a device against high quality reference equipment (factory level standard). The comparison is performed in accordance with internal procedures that comply with ISO 9001 and provides information on the specimen's measuring accuracy. The reference equipment is traceable to national standards, however, the calibration process is not accredited. Therefore, an ISO 9001 calibration is neither traceable nor internationally comparable.

Visit www.epluse.com/iso9001cal for detailed information on calibration and to enquire an ISO 9001 calibration certificate.

Dimensions

Values in mm (inch)

Type T1 (wall mount)

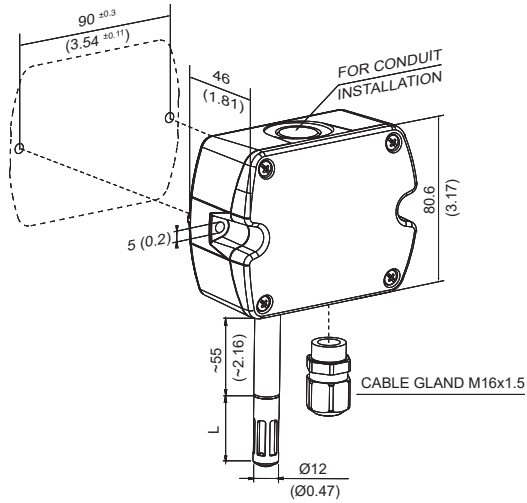

Type T2 (duct mount)

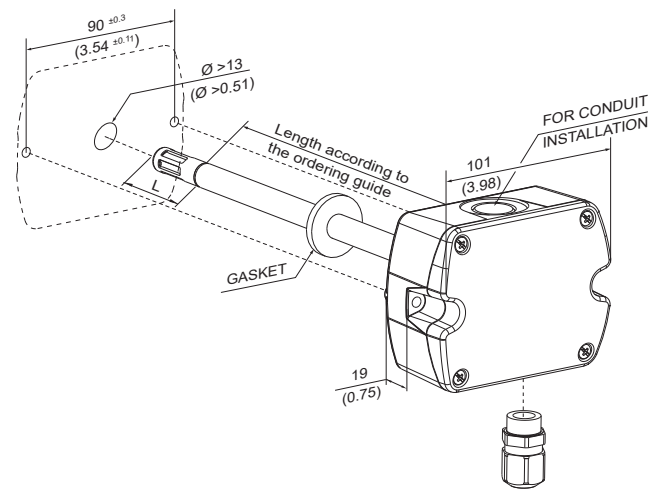

L = filter cap length	mm (inch)
Membrane	34 (1.34)
Stainless steel	31 (1.22)
Metal grid	33 (1.30)

Dimensions

Values in mm (inch)

Type T3 (remote probe)

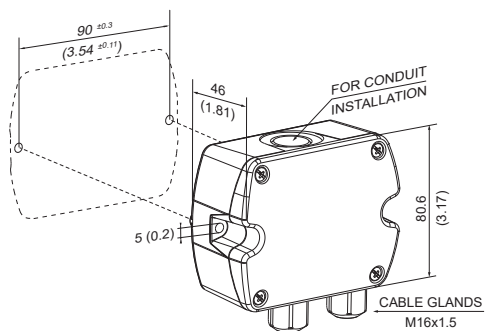

PE210

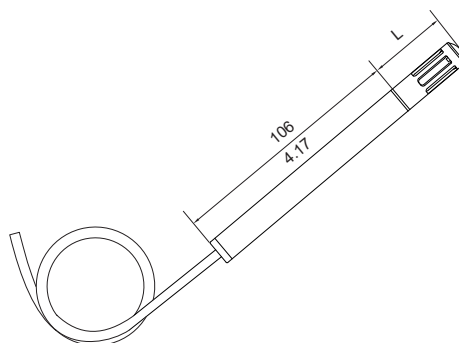

Type T13 (outdoor)

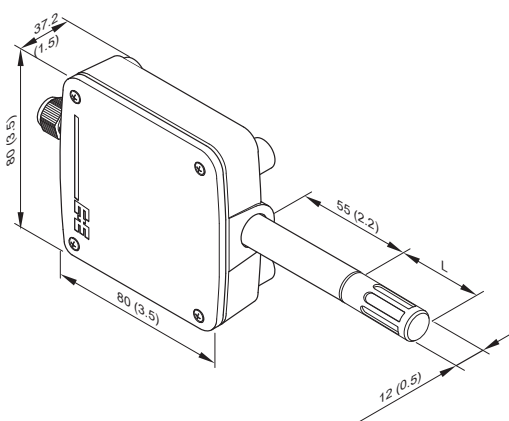

Mounting flange

in the scope of supply for type T2 and T3

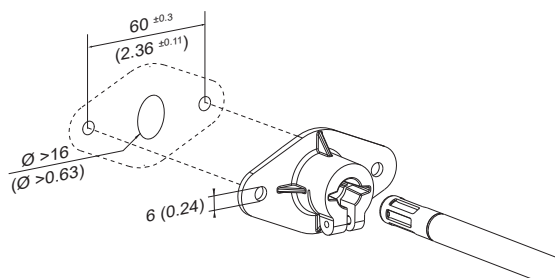

Radiation shield HA010501 for type T13 (outdoor)

needs to be ordered separately

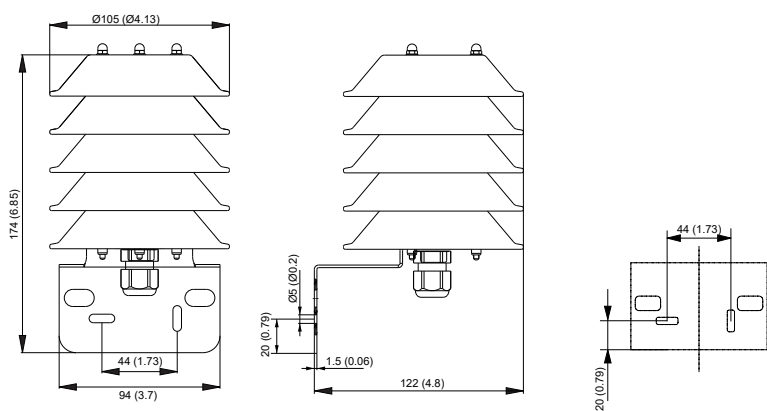

Technical Data

Measurands

Relative humidity (RH)

Measuring range	0...100 % RH
Accuracy¹⁾ incl. hysteresis, non-linearity and repeatability	
Type T1, T2 -15...+40 °C (+5...+104 °F), ≤90 %RH -15...+40 °C (+5...+104 °F), >90 %RH -40...+60 °C (-40...+140 °F)	±(1.3 + 0.003*measured value) %RH ±2.3 %RH ±(1.5 + 0.015*measured value) %RH
Type T3 @ 20 °C (68 °F)	±2.5 %RH
Type T13 -15...+40 °C (+5...+104 °F), ≤90 %RH -15...+40 °C (+5...+104 °F), ≥90 %RH -40...+60 °C (-40...+140 °F)	±(1.6 + 0.005*measured value) %RH ±3 %RH ±(2.3 + 0.008*measured value) %RH

1) Traceable to international standards, administrated by NIST, PTB, BEV,...
The accuracy statement includes the uncertainty of the factory calibration with an coverage factor k=2 (2-times standard deviation).
The accuracy was calculated in accordance with EA-4/02 and with regard to GUM (Guide to the Expression of Uncertainty in Measurement).
For Type T13: @ 24 V DC and RL=250 Ω for A6 Versions.

Temperature (T)

Measuring range	Type T1, T2, T13 -40...+60 °C (-40...+140 °F) Type T3 (probe) -40...+80 °C (-40...+176 °F) Type T3 (enclosure) -40...+60 °C (-40...+140 °F)
Accuracy	<p>Type T1,T2</p> <p>Type T3</p> <p>Type T13</p>

Technical Data

Measurands

Calculated measurands

		from		up to		unit	
Dew point temperature	T _d ¹⁾	-40	(-40)	60	(140)	°C	(°F)
Frost point temperature	T _f ²⁾	-40	(-40)	0	(32)	°C	(°F)
Wet bulb temperature	T _w	0	(32)	60	(140)	°C	(°F)
Water vapour partial pressure	e	0	(0)	200	(3)	mbar	(psi)
Mixing ratio	r	0	(0)	160	(1200)	g/kg	(gr/lb)
Absolute humidity	dv	0	(0)	150	(60)	g/m ³	(gr/ft ³)
Specific enthalpy	h	-40	(-10)	500	(200)	kJ/kg	(BTU/lb)

1) T_d accuracy according to RH and T uncertainties, please use the [E+E Humidity Calculator](#) for details.
 2) Equals T_d above 0 °C (32 °F).

Outputs

Analogue



Two freely selectable and scalable outputs	0 - 5 V / 0 - 10 V	-1 mA < I _L < 1 mA	I _L = load current R _L = load resistance
	4 - 20 mA (2-wire)	R _L ≤ 500 Ω	
	0 - 20 mA (3-wire)	250 ≤ R _L ≤ 500 Ω recommended for type T13 R _L ≤ 500 Ω	

Digital

Digital interface	RS485 (EE210 = 1 unit load)
Protocol	Modbus RTU
Factory settings	Baud rate according to ordering guide, parity even, 1 stop bit, Modbus address 242
Supported Baud rates	9600, 19200 and 38400
Data types for measured values	FLOAT32 and INT16

Technical Data

General

Power supply class III  USA & Canada: Class 2 supply necessary, max. voltage 30 V DC	4 - 20 mA (2-wire)	$(10\text{ V} + R_L \cdot 20\text{ mA}) < V+ < 30\text{ V DC}$ for type T13: 24 V DC $\pm 10\%$ recommended	
	0 - 5 V / 0 - 10 V 0 - 20 mA (3-wire) RS485	15 - 35 V DC or 24 V AC $\pm 20\%$	
Current consumption at 24 V	Voltage output	DC supply max. 12 mA AC supply max. 34 mA _{rms}	with display max. 23 mA with display max. 49 mA _{rms}
	Current output 2-wire	DC supply max. 40 mA	with display max. 40 mA
	Current output 3-wire	DC supply typ. 33 mA AC supply typ. 65 mA _{rms}	with display max. 44 mA with display max. 84 mA _{rms}
	Digital interface	DC supply typ. 5 mA AC supply typ. 15 mA _{rms}	with display max. 20 mA with display max. 35 mA _{rms}
Electrical connection	Screw terminals, max. 1.5 mm ²		
Cable gland	M16x1.5		
Display¹⁾	Available for type T1/T2/T3 1, 2 or 3 lines, user configurable Optional with backlight		
Temperature ranges		Without display	With display
	Operation	-40...+60 °C (-40...+140 °F) -40...+80 °C (-40...+176 °F) for probe PE210	-20...+50 °C (-4...+122 °F) -40...+80 °C (-40...+176 °F) for probe PE210
	Storage	-40...+60 °C (-40...+140 °F)	-20...+60 °C (-4...+140 °F)
Enclosure	Material Protection rating	PC (Polycarbonate), UL94 V-0 (with display UL94 HB) approved IP65/NEMA 4X	
Electromagnetic compatibility	EN 61326-1 FCC Part15 Class A	EN 61326-2-3 ICES-003 Class A	Industrial environment
Conformity	 		

1) For display operation with EE210-M1xA6 (4 - 20 mA, 2-wire) both outputs must be connected.

Ordering Guide

Feature	Description	Code			
		EE210-			
Model	RH + T	M1			
Type	Wall mount	T1			
	Duct mount		T2		
	Remote probe ¹⁾		T3		
	Outdoor			T13	
Probe length	50 mm (1.97")		L50		
	200 mm (7.84")		L200		
Output	0 - 5 V		A2		
	0- 10 V		A3		A3
	0 - 20 mA (3-wire)		A5		
	4 - 20 mA (2-wire)		A6		A6
	RS485		J3		
Filter	Membrane	F2			
	Metal grid	F3			F3
	Stainless steel sintered	F4			
Display²⁾	Without display	No code			
	Without backlight ³⁾		D1		
	With backlight ⁴⁾		D2		
Output 1 measurand	Relative humidity RH [%]	No code			
	Temperature T [°C]	MA1			
	Temperature T [°F]	MA2			
	Other measurands (xx see measurand code)	MAxx			
Output 1 scaling low	0	No code			
	Value	SALValue			
Output 1 scaling high	100	No code			
	Value	SAHValue			
Output 2 measurand	Temperature T [°C]	No code			
	Temperature T [°F]	MB2			
	Other measurands (xx see measurand code)	MBxx			
Output 2 scaling low	Value	SBLValue			
Output 2 scaling high	Value	SBHValue			
Protocol	Modbus RTU ⁵⁾	P1			
Baud rate	9600	BD5			
	19200	BD6			
	38400	BD7			
Units	Metric (SI)	No code			
	Non metric (US/GB)	U2			
Accredited Traceable Calibration Certificate in accordance with DIN EN ISO/IEC 17025		see www.epluse.com			
ISO 9001 Calibration Certificate		see www.epluse.com/iso9001cal			

- 1) The PE210 probe has to be ordered as separate position.
- 2) Factory setup: For analogue output versions the display shows the measurands selected for output 1 and output 2. For digital output versions the display shows RH and T.
- 3) Not with output A5.
- 4) Not with output A6.
- 5) Modbus Map and setup instructions: See User Guide and Modbus Application Note at www.epluse.com/ee210.

Ordering Guide PE210

Feature	Description	Code
		PE210-
Model	RH + T	M1
Filter	Membrane	F2
	Metal grid	F3
	Stainless steel sintered	F4
Connection cable length	1.5 m (4.9 ft)	KL150
	3 m (9.8 ft)	KL300

Measurand Code

For Output 1 and 2 in the Ordering Guide

Measurand	Unit	Code
		MAxx / MBxx
Relative humidity	%	10
Temperature	°C °F	1 2
Dew point	Td °C °F	52 53
Frost point	Tf °C °F	65 66
Mixing ratio	r g/kg gr/lb	60 61
Absolute humidity	dv g/m³ gr/ft³	56 57
Wet bulb temperature	Tw °C °F	54 55
Water vapour partial pressure	e mbar psi	50 51
Specific enthalpy	h kJ/kg BTU/lb	62 64

i PLEASE NOTE

No mix of SI/US units allowed.

Order Examples

Type T1 and T2

EE210-M1T1A3F2D2SBL-40SBH60

Feature	Code	Description
Model	M1	RH + T
Type	T1	Wall mount
Output	A3	0 - 10 V
Filter	F2	Membrane
Display	D2	With backlight
Output 1 measurand	No code	Relative humidity RH [%]
Output 1 scaling low	No code	0 %RH
Output 1 scaling high	No code	100 %RH
Output 2 measurand	No code	Temperature T [°C]
Output 2 scaling low	SBL-40	-40 °C
Output 2 scaling high	SBH60	60 °C

Order Examples

Type T3 Position 1: Basic Device

EE210-M1T3A6MB52SBL-10SBH50

Feature	Code	Description
Model	M1	RH + T
Type	T3	Remote probe
Output	A6	4 - 20 mA (2-wire)
Display	No code	Without display
Output 1 measurand	No code	Relative humidity RH [%]
Output 1 scaling low	No code	0 %RH
Output 1 scaling high	No code	100 %RH
Output 2 measurand	MB52	Dew Point Temperature Td [°C]
Output 2 scaling low	SBL-10	-10 °C
Output 2 scaling high	SBH50	50 °C

Position 2: Remote Probe

PE210-M1F3KL150

Feature	Code	Description
Model	M1	RH + T
Filter	F3	Metal grid
Connection cable length	KL150	1,5 m (4.9 ft)

Type T13 Position 1:

EE210-M1T13A6F3SBL-40SBH60

Feature	Code	Description
Model	M1	RH + T
Type	T13	Outdoor
Output	A6	4 - 20 mA (2-wire)
Filter	F3	Metal grid
Display	No code	Without display
Output 1 measurand	No code	Relative humidity RH [%]
Output 1 scaling low	No code	0 %RH
Output 1 scaling high	No code	100 %RH
Output 2 measurand	No code	Temperature T [°C]
Output 2 scaling low	SBL-40	-40 °C
Output 2 scaling high	SBH60	60 °C

Position 2:

HA010501

Radiation shield for EE210 Outdoor.

Accessories

For further information refer to "[Accessories](#)" the datasheet.

Accessories	Code
USB-C configuration stick	HA011070
Product Configuration Software (Free download: www.epluse.com/pcs10)	PCS10
Radiation shield for EE210 Outdoor (Type T13)	HA010501
Power supply adapter 24 V DC	V03
Protection cap for Ø12 mm (0.47") probe, RAL6018	HA010783



Company Headquarters &
Production Site

E+E Elektronik Ges.m.b.H.
Langwiesen 7
4209 Engerwitzdorf | Austria
T +43 7235 605-0
F +43 7235 605-8
info@epluse.com
www.epluse.com

Subsidiaries

E+E Sensor Technology (Shanghai) Co., Ltd.
T +86 21 6117 6129
info@epluse.cn

E+E Elektronik France SARL
T +33 4 74 72 35 82
info.fr@epluse.com

E+E Elektronik Deutschland GmbH
T +49 6171 69411-0
info.de@epluse.com

E+E Elektronik India Private Limited
T +91 990 440 5400
info.in@epluse.com

E+E Elektronik Italia S.r.l.
T +39 02 2707 86 36
info.it@epluse.com

E+E Elektronik Korea Ltd.
T +82 31 732 6050
info.kr@epluse.com

E+E Elektronik Corporation
T +1 847 490 0520
info.us@epluse.com



—
your partner
in sensor
technology.