



Ultrasonic Distance Sensor

Featuring LoRaWAN[®]

EM400-UDL

User Guide



Safety Precautions

Milesight will not shoulder responsibility for any loss or damage resulting from not following the instructions of this operating guide.

- ❖ The device must not be disassembled or remodeled in any way.
- ❖ In order to protect the security of the device, please change the device password when first configuration. Default password is 123456.
- ❖ The device is not intended to be used as a reference sensor, and Milesight won't should responsibility for any damage which may result from inaccurate readings.
- ❖ Do not place the device close to objects with naked flames.
- ❖ Do not place the device in where the temperature is below/above the operating range.
- ❖ Make sure both batteries are newest when install, or battery life will be reduced.
- ❖ The device must never be subjected to shocks or impacts.

Declaration of Conformity

EM400-UDL is in conformity with the essential requirements and other relevant provisions of the CE, FCC, and RoHS.

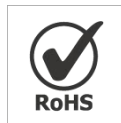

Copyright © 2011-2023 Milesight. All rights reserved.

All information in this guide is protected by copyright law. Whereby, no organization or individual shall copy or reproduce the whole or part of this user guide by any means without written authorization from Xiamen Milesight IoT Co., Ltd.

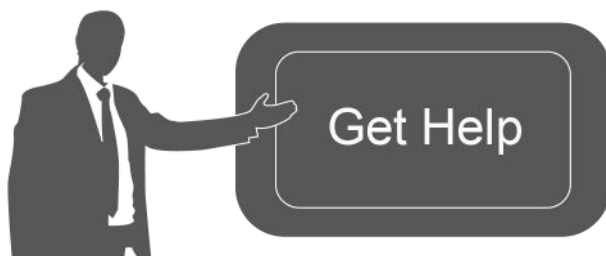

For assistance, please contact

Milesight technical support:

Email: iot.support@milesight.com

Support Portal: support.milesight-iot.com

Tel: 86-592-5085280

Fax: 86-592-5023065

Address: Building C09, Software Park III,
Xiamen 361024, China

Revision History

Date	Doc Version	Description
March 16, 2023	V 1.0	Initial version

Contents

1. Product Introduction	4
1.1 Overview	4
1.2 Features	4
2. Hardware Introduction	4
2.1 Packing List	4
2.2 Hardware Overview	5
2.3 Dimensions (mm)	5
2.4 Power Button	5
3. Operation Guide	5
3.1 NFC Configuration	5
3.2 LoRaWAN Settings	6
3.3 Basic Settings	10
3.4 Advanced Settings	10
3.4.1 Calibration Settings	10
3.4.2 Threshold Settings	11
3.5 Maintenance	11
3.5.1 Upgrade	11
3.5.2 Backup	12
3.5.3 Reset to Factory Default	13
4. Installation	13
5. Device Payload	14
5.1 Basic Information	14
5.2 Sensor Data	15
5.3 Downlink Commands	16

1. Product Introduction

1.1 Overview

EM400-UDL is a designed non-contact ultrasonic distance sensor featuring LoRaWAN[®]. With this low power consumption technology, EM400-UDL can work up to 10 years with two 9000 mAh batteries. With multiple probes optional and different detecting ranges, it can satisfy different requirements.

With high protection IP rating and waterproof enclosure, EM400-UDL is widely used for outdoor applications such as water level, fill level of tanks and silos, presence of objects or snow level. Combining with Milesight LoRaWAN[®] gateway and Milesight IoT Cloud solution, users can manage all sensor data remotely and visually.

1.2 Features

- Optional probes vary from 25 to 1000cm for multiple applications
- Equipped with NTC Thermistor for the detection and alarm of burning
- Built-in 3-axis accelerometer sensor to monitor device tilt status
- Damp-proof coating inside and IP67 waterproof enclosure for outdoor applications
- Built-in two 9000 mAh replaceable batteries and work for 10 years without replacement
- Ultra-wide-distance wireless transmission up to line of sight of 15km
- Equipped with NFC for one touch configuration, support card emulation mode
- Function well with standard LoRaWAN[®] gateway and network servers
- Compatible with Milesight IoT Cloud

2. Hardware Introduction

2.1 Packing List



1 × EM400-UDL
Device

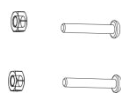

2 × Mounting
Kits



1 × Warranty
Card



1 ×
Quick Guide



If any of the above items is missing or damaged, please contact your sales representative.

2.2 Hardware Overview

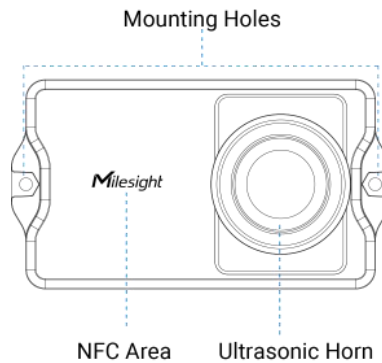

2.3 Dimensions (mm)

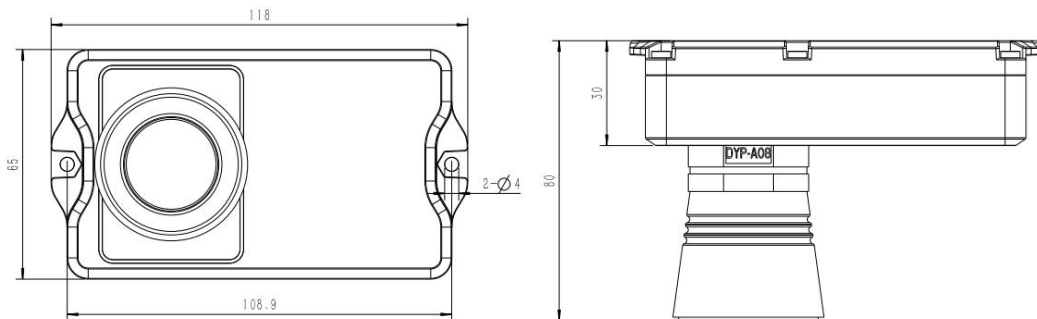

2.4 Power Button

EM400-UDL can be switched on/off via NFC. Besides, users can use power button to switch on/off and reset the device manually.

Function	Action	LED Indication
Switch On	Press and hold the button for more than 3 seconds.	Off → On
Switch Off	Press and hold the button for more than 3 seconds.	On → Off
Reset	Press and hold the button for more than 10 seconds.	Quickly Blinks
Check On/Off Status	Quickly press the power button.	Light On: Device is on Light Off: Device is off

3. Operation Guide

3.1 NFC Configuration

EM400-UDL can be configured via NFC.

1. Download and install “Milesight ToolBox” App from Google Play or App Store.
2. Enable NFC on the smartphone and open “Milesight ToolBox” App.
3. Attach the smartphone with NFC area to the device to read the basic information.



4. Basic information and settings of devices will be shown on ToolBox if it's recognized successfully. You can switch on/off, read and write the device by tapping the button on the Apps. In order to protect the security of devices, password validation is required when configuring via unused phone. Default password is **123456**.

Status	Setting	Maintenance
SN	6329C42903640033	
Model	EM400-UDL-470M	
PN		C050
Device EUI	24E124329C429036	
Firmware Version		V1.1-a4
Hardware Version		V1.0
Device Status		ON <input checked="" type="checkbox"/>

Note:

- 1) Ensure the location of smartphone NFC area and it's recommended to take off phone case.
- 2) If the smartphone fails to read/write configurations via NFC, keep the phone away and back to try again.
- 3) EM400-UDL can also be configured by dedicated NFC reader provided by Milesight IoT or you can configure it via TTL interface inside the device.

3.2 LoRaWAN Settings

LoRaWAN settings is used for configuring the transmission parameters in LoRaWAN® network.

Basic LoRaWAN Settings:

Go to **Device > Setting > LoRaWAN Settings** of ToolBox App to configure join type, App EUI, App Key and other information. You can also keep all settings by default.

Device EUI

* APP EUI

* Application Port 85

Join Type

* Application Key

LoRaWAN Version

Work Mode

RX2 Data Rate

RX2 Frequency

Confirmed Mode

Rejoin Mode

Set the number of detection signals sent

ADR Mode

Spreading Factor

TXPower

Parameters	Description
Device EUI	Unique ID of the device which can also be found on the label.
App EUI	Default App EUI is 24E124C0002A0001.
Application Port	The port used for sending and receiving data, default port is 85.
Join Type	OTAA and ABP mode are available.
Application Key	Appkey for OTAA mode, default is 5572404C696E6B4C6F52613230313823.
Device Address	DevAddr for ABP mode, default is the 5 th to 12 th digits of SN.
Network Session Key	Nwkskey for ABP mode, default is 5572404C696E6B4C6F52613230313823.
Application Session Key	Appskey for ABP mode, default is 5572404C696E6B4C6F52613230313823.
LoRaWAN Version	V1.0.2, V1.0.3 are available.
Work Mode	It's fixed as Class A.
RX2 Data Rate	RX2 data rate to receive downlinks.
RX2 Frequency	RX2 frequency to receive downlinks. Unit: Hz
Spread Factor	If ADR is disabled, the device will send data via this spread factor.
Confirmed Mode	If the device does not receive ACK packet from network server, it will resend data once.
Rejoin Mode	Reporting interval \leq 30 mins: the device will send a specific number of LinkCheckReq MAC packets to the network server every 30 mins to validate connectivity; if there is no response, the device will re-join the network. Reporting interval $>$ 30 mins: the device will send a specific number of LinkCheckReq MAC packets to the network server every reporting interval to validate connectivity; if there is no response, the device will re-join the network.
Set the number of packets sent	When rejoin mode is enabled, set the number of LinkCheckReq packets sent.
ADR Mode	Allow network server to adjust datarate of the device.
Tx Power	Transmit power of device.

Note:

- 1) Please contact sales for device EUI list if there are many units.
- 2) Please contact sales if you need random App keys before purchase.
- 3) Select OTAA mode if you use Milesight IoT cloud to manage devices.
- 4) Only OTAA mode supports rejoin mode.

LoRaWAN Frequency Settings:

Go to **Setting > LoRaWAN Settings** of ToolBox App to select supported frequency and select channels to send uplinks. Make sure the channels match the LoRaWAN® gateway.

* Support Frequency

EU868

868.1

868.3

868.5

863

If frequency is one of CN470/AU915/US915, you can enter the index of the channel that you want to enable in the input box, making them separated by commas.

Examples:

1, 40: Enabling Channel 1 and Channel 40

1-40: Enabling Channel 1 to Channel 40

1-40, 60: Enabling Channel 1 to Channel 40 and Channel 60

All: Enabling all channels

Null: Indicates that all channels are disabled

* Support Frequency

AU915

Enable Channel Index ⓘ

0-71

Index	Frequency/MHz ⓘ
0 - 15	915.2 - 918.2
16 - 31	918.4 - 921.4
32 - 47	921.6 - 924.6
48 - 63	924.8 - 927.8

3.3 Basic Settings

Go to **Device > Setting > General Settings** to change the reporting interval, etc.

Reporting Interval min

Tilt & Distance Switch i

Change Password

Parameters	Description
Reporting Interval	Reporting interval of transmitting data to network server. Default: 10 mins
Tilt & Distance Switch	When detecting that the offset angle is greater than 20 degrees, turn off the distance sensor.
Change Password	Change the password for ToolBox App or software to access this device.

3.4 Advanced Settings

3.4.1 Calibration Settings

Go to **Device > Settings > Calibration Settings** to enable calibration. EM400-UDL supports two calibration types.

- **Numerical Calibration:** users can define calibration value to correct every distance.

Calibration Settings ^

Distance

Numerical Calibration

Current Value: 3.164 m

Calibration Value

m

Final Value: 3.164 m

- **Measure Outlier Calibration:** users can define either outlier range or value. When the device distance value exceeds the outlier range (or range) comparing to last value, the device will measure the distance again.

Measure Outlier Calibration (i)

Maximum Range: 5 m

Outlier Range / % (i)Outlier Value / m (i)

3.4.2 Threshold Settings

Go to **Device > Setting > Threshold Settings** to enable the threshold settings and input the distance threshold. EM400-UDL will detect whether the distance reaches the threshold according to collecting interval. If threshold is triggered, it uploads the current data once instantly.

Distance

Over / m

Below / m

Collecting Interval 10 minThreshold Dismiss Report (i)

Parameters	Description
Collecting Interval	Collecting interval of ultrasonic sensor to detect distance. Range: 1~1080min
Threshold Dismiss Report	When the collected value changes from outside the threshold to within the threshold, a threshold release packet will be reported.

3.5 Maintenance

3.5.1 Upgrade

1. Download firmware from Milesight website to your smartphone.
2. Open Toolbox App, go to **Device > Maintenance** and click **Browse** to import firmware and

upgrade the device.

Note:

- 1) Operation on ToolBox is not supported during a firmware upgrade.
- 2) Only Android version ToolBox supports the upgrade feature.

Status	Setting	Maintenance
SN	6329C42903640033	
Model	EM400-UDL-470M	
Firmware Version	V1.1-a4	
Hardware Version	V1.0	
Manual Upgrade		

Browse

3.5.2 Backup

EM400-UDL support configuration backup for easy and quick device configuration in bulk. Backup is allowed only for devices with the same model and LoRaWAN® frequency band.

1. Go to **Template** page on the App and save current settings as a template. You can also edit the template file.
2. Select one template file which saved in the smartphone and click **Write**, then attach to another device to write configuration.

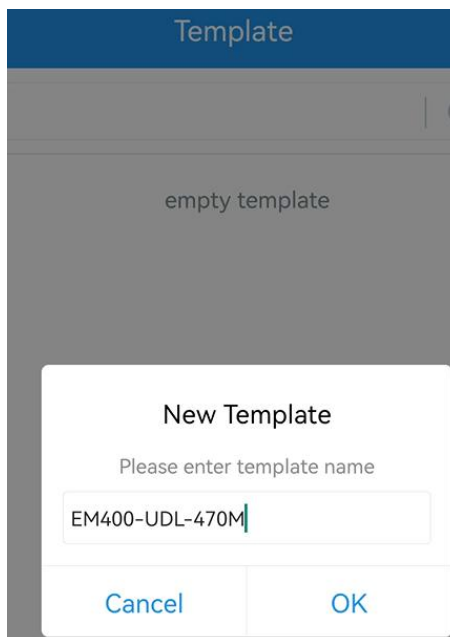

Note: Slide the template item left to edit or delete the template. Click the template to edit the configurations.

Template	
<input type="text"/>	<input type="button" value="Q"/>
e: 2023-03-08 09:33:28	<input type="button" value="Edit"/> <input type="button" value="Delete"/>
<input type="button" value="[-"/> EM400-MUD	Last Modified Time: 2023-03-08 09:33:46
<input type="button" value="[-"/> EM400-UDL_20230308	Last Modified Time: 2023-03-08 09:35:10

3.5.3 Reset to Factory Default

Please select one of following methods to reset device:

Via Hardware: Hold on power button (internal) for more than 10s.

Via Toolbox App: Go to **Device > Maintenance** to click **Reset**, then attach smartphone with NFC area to device to complete reset.

Status	Setting	Maintenance
SN	6329C42903640033	
Model	EM400-UDL-470M	
Firmware Version	V1.1-a4	
Hardware Version	V1.0	
Manual Upgrade		
<input type="button" value="Browse"/>		
Restore Factory Default		
<input type="button" value="Reset"/>		

4. Installation

1. Drill two holes on the container cover according to the location of device mounting holes.
2. Put the device under container cover and align the holes in order to perfectly screw the bolts into the holes from the other side of the cover.

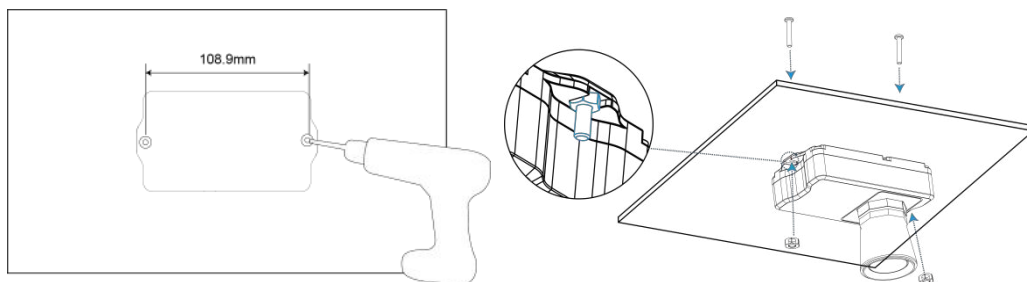

Besides, the device can also be fixed by two M4 mounting screws and wall plugs.

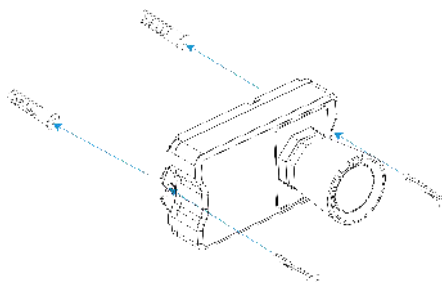

Installation Note:

- In order to provide the best data transmission, please ensure the device is deployed within the signal range of the LoRaWAN® gateway and keep it away from metal objects and obstacles.
- The device must be placed in a horizontal position above the detected object so that it has a clear path to the object.
- The device should be installed at least 30cm away from the side-wall without obstructions blocking the ultrasonic signal. If the device needs to be installed on the side wall, please ensure the ultrasonic horn is away from the side wall.
- Do not install the ultrasonic sensor above the influent stream to ensure the measured surface rather than the incoming stream.

5. Device Payload

All data are based on following format (HEX):

Channel1	Type1	Data1	Channel2	Type2	Data2	Channel 3	...
1 Byte	1 Byte	N Bytes	1 Byte	1 Byte	M Bytes	1 Byte	...

For decoder examples please find files on <https://github.com/Milesight-IoT/SensorDecoders>.

5.1 Basic Information

EM400-UDL reports basic information of sensor whenever it joins the network.

Channel	Type	Description
---------	------	-------------

ff	01(Protocol Version)	01=>V1
	09 (Hardware Version)	01 40 => V1.4
	0a (Software Version)	01 14 => V1.14
	0b (Power On)	Device is on
	0f (Device Type)	00: Class A, 01: Class B, 02: Class C
	16 (Device SN)	16 digits

Example:

ff0bff ff0101 ff166329c42903640033 ff090100 ff0a0101 ff0f00					
Channel	Type	Value	Channel	Type	Value
ff	0b (Power On)	ff (Reserved)	ff	01 (Protocol Version)	01 (V1)
Channel	Type	Value	Channel	Type	Value
ff	16 (Device SN)	6329c42903 640033	ff	09 (Hardware version)	0100 (V1.0)
Channel	Type	Value	Channel	Type	Value
ff	0a (Software version)	0101 (V1.1)	ff	0f (Device Type)	00 (Class A)

5.2 Sensor Data

EM400-UDL reports sensor data according to reporting interval (10 mins by default).

Channel	Type	Description
01	75(Battery Level)	UINT8, Unit: %
03	67 (Temperature)	INT16, Unit: °C
04	82 (Distance)	INT16, Unit: mm
05	00 (Device Position)	00: Normal (horizontal offset angle < 20°) 01: Tilt (horizontal offset angle ≥ 20°)

Example:

017564 0367f800 04820101 050001					
Channel	Type	Value	Channel	Type	Value
01	75 (Battery)	64 => 100%	03	67 (Temperature)	f8 00 => 00 f8 = 248 * 0.1 =24.8 °C
Channel	Type	Value	Channel	Type	Value
04	82 (Distance)	01 01 => 01 01 =257mm	05	00 (Device Position)	01=Tilt

		=0.257m			
--	--	---------	--	--	--

Threshold Packet:

When collected distance exceeds threshold, EM400-UDL will report a distance alarm packet; besides, it will also report a alarm dismiss packet if distance returns back to normal value. When the abrupt change of temperature is greater than 5 °C, it will report a temperature alarm packet.

Channel	Type	Description
84	82 (Distance)	3 Bytes, Distance (2 Bytes) + Alarm Status (1 Byte) Distance: unit -- mm Alarm Status: 00 -Alarm dismiss 01 -Alarm
83	67 (Temperature)	3 Bytes, Temperature (2 Bytes) + Alarm Status (1 Byte) Temperature: unit -- °C Alarm Status: 00 -Alarm dismiss 01 -Alarm

Example:

1. Distance Threshold

8482330701		
Channel	Type	Value
84	82 (Distance)	Distance: 33 07 =>07 33 = 1843mm = 1.843m Alarm Status: 01= Alarm

2. Temperature Threshold

8367220101		
Channel	Type	Value
83	67 (Temperature)	Temperature: 22 01 =>01 22 = 290 * 0.1 = 29°C Alarm Status: 01= Alarm

5.3 Downlink Commands

EM400-UDL supports downlink commands to configure the device. Application port is 85 by default.

Channel	Type	Description
---------	------	-------------

ff	10 (Reboot)	ff (Reserved)
	03 (Set Reporting Interval)	2 Bytes, unit: s
	3e (Set Tilt & Distance Switch)	00 = Disable; 01 = Enable
	06 (Set Threshold Alarm)	9 Bytes, CTRL(1B)+Min(2B)+Max(2B)+00000000(4B) CTRL: Bit2~Bit0: 000-disable 001-below 010-above 011-within 100-below or above Bit5~Bit3=001 Bit6=0 Bit7: 0 - disable threshold dismiss report 1 - enable threshold dismiss report

Example:

1. Set reporting interval as 20 minutes.

ff03b004		
Channel	Type	Value
ff	03 (Set Reporting Interval)	b0 04 => 04 b0 = 1200s = 20 minutes

2. Reboot the device.

ff10ff		
Channel	Type	Value
ff	10 (Reboot)	ff (Reserved)

3. Enable "Tilt & Distance Switch" feature.

ff3e01		
Channel	Type	Value
ff	3e (Set Tilt & Distance Switch)	01 = Enable

4. When the distance is below 1 m or above 3 m, the sensor will trigger threshold alarm.

ff06 8c e803 b80b 0000 0000		
Channel	Type	Value
ff	06 (Set Threshold Alarm)	CTRL: 8c=10 001 100 100=below or above 10=enable threshold dismiss report Min: e8 03=> 03 e8 =1000mm =1m Max: b80b => 0b b8 =3000mm =3m

-END-