

Hydroponics Sensor Transmitter & Controller Temperature, pH, EC (+ORP) & Flow



Shown with options



Contents

Warnings & Notices	2	Temperature Calibration	12
Features	3	pH Calibration	12
Technical Information	3	Conductivity Calibration	13
Specifications	3	O.R.P. Calibration	13
Storage and Disposal	3	Advanced Calibration	14
Installation Instructions	4	Analog Output Calibration	14
Mounting the Transmitter	4	Setup Menu	15
DIN Rail Mounting Kit	4	Time / Date	15
Connecting Sensor Probes	4	Units	15
PPX Probe Pontoon	5	Logging Interval	16
PBX Probe Manifolds	5	COMM Mode	17
Optional Power Supply	6	Device Address	17
Connection to ADi Pump	6	Manufacturing Info	17
Connection to GrowControl™ GCX	7	Display Back Light Timer	18
GrowNET™ Hubs	7	Connection to 4-20mA Outputs	19
pH & ORP Probe Preparation	8	Connection to USB AgrowLINK	19
LCD Menu Operation Instructions	9	Connection to MODBUS RTU	20
High / Low History	9	Serial Speed & Format	20
Graphing	9	Supported Commands	21
Main Menu	10	Register Types	21
Alarms Menu	10	Sensor Value Registers	21
Alarms Configuration	10	Calibration Registers	21
Alarm Buzzer	11	MODBUS Holding Registers	23
Calibration Menu	11	Maintenance	24
Clear Calibration	11	Probe Cleaning	24
		pH Probe Reconditioning	24
		Warranty	25

KEEP THESE INSTRUCTIONS

This product is intended for commercial use only.

REV 03/26

Warnings & Notices

This is a precision electronic instrument which requires proper installation and care to maintain reliability.

READ & UNDERSTAND ENTIRE MANUAL PRIOR TO INSTALLATION OR OPERATION.

Failure to read, understand and comply with warnings and installation requirements may result in property damage, personal injury or death.

WARNING

Do not use a power supply other than the intended or included power supply. Do not exceed the maximum ratings on the product serial label or specifications listed in this manual. Any power supply with energy levels exceeding the specifications must be current limited or fused to prevent overcurrent to the device.

NOTICE

GrowNET™ ports use standard RJ-45 connections but are NOT compatible the Ethernet network equipment. *Do not connect GrowNET™ ports to Ethernet ports or network switch gear.*

DIELECTRIC GREASE

Dielectric grease is recommended on RJ-45 GrowNET™ connections when used in humid environments. Place a small amount of grease onto the RJ-45 plug contacts before inserting into the GrowNET™ port. *Non-conductive grease is designed to prevent corrosion from moisture in electrical connectors.*

- Loctite LB 8423
- Dupont Molykote 4/5
- CRC 05105 Di-Electric Grease
- Super Lube 91016 Silicone Dielectric Grease
- Other Silicone or Lithium based insulating grease

INDOOR LOCATIONS ONLY

This product is designed for indoor mounting only and must be protected from weather and direct sunlight.

WARNING

This product may contain chemicals known to the State of California to cause cancer and birth defects or other reproductive harm.



Wear skin and eye protection when working with hazardous chemicals.

NOTICE

pH and ORP probes must remain wet to avoid damage. Do not allow probe tips to dry. *Minimum recommended moisture content in rockwool 40% VWC.*

WARNING

pH and ORP probe tips contain a delicate glass bulb. Do not impact the glass bulb or breakage may occur resulting in hazardous glass shards and permanent probe damage.

Features

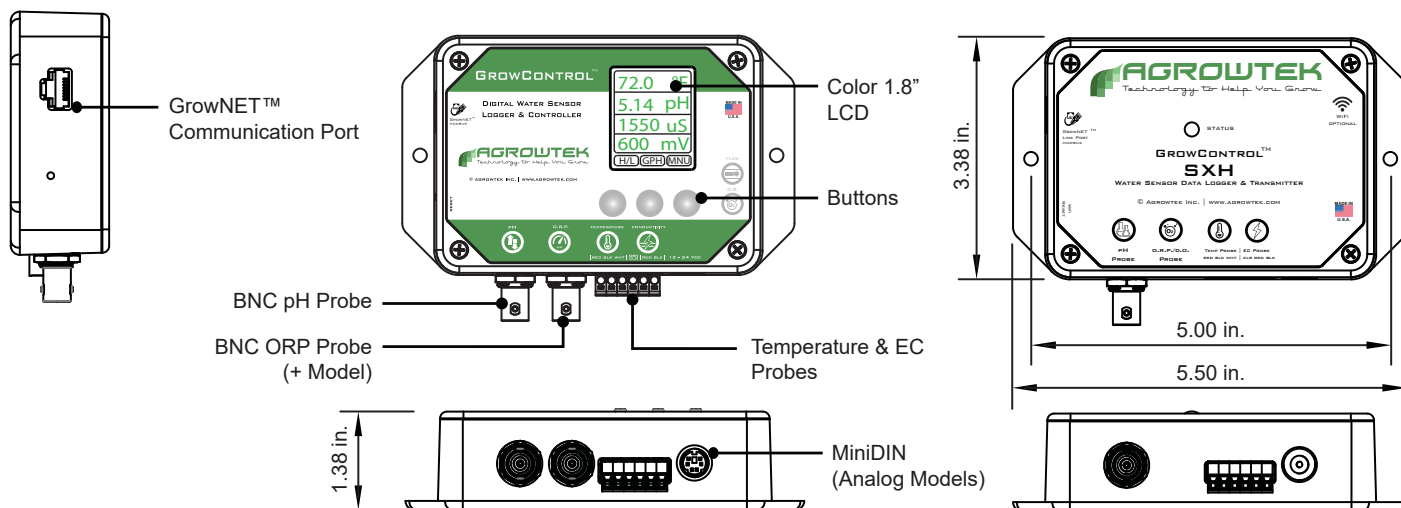

Technical Information

Specifications

Power	24Vdc, ~2W (5W w/LCD)
Max Cable Distance	1000ft
Optional Interface	LCD w/3 Buttons
Temperature Range	-20 - 60°C
Temperature Accuracy	±2°C, 0.1° resolution
pH Range	0 - 14pH
pH Accuracy	±0.03pH, 0.01pH resolution
Conductivity Range	0 - 7,000 uS (0 - 3500ppm) 0 - 80,000 uS (high salinity / salt water model)
Conductivity Accuracy	< 2000uS ±20uS, >2000uS ±50uS; 2uS resolution
+ORP Range	-1000 - +1000mV
+ORP Accuracy	±10mV, 1mV resolution
4-20mA Output Resolution	12 bit , 0.005mA
Interface	GrowNET™ or MODBUS RTU

Storage and Disposal

Storage

Store equipment in a clean, dry environment with ambient temperature between 10-50°C.

Disposal

This industrial control equipment may contain traces of lead or other metals and environmental contaminants and must not be discarded as unsorted municipal waste, but must be collected separately for the purpose of treatment, recovery and environmentally sound disposal. Wash hands after handling internal components or PCB's.

Installation Instructions

Install with the transmitter in the orientation shown in dimension drawings with the temperature probe connections facing down to reduce the risk of water permeating the enclosure.

Avoid locations with dripping water or heavy splash risk; the transmitter is best kept dry for longest life and highest accuracy. Mounting in an enclosure is recommended in extreme humidity or splash/spray locations.

Mounting the Transmitter

Wall mounting tabs are provided for installing against a vertical wall surface.

1. Measure out the hole locations per the dimensions, or mark the holes using the transmitter as a template.
2. Drill holes and install anchors (if required, not included.) Keep the transmitter away from dust during work.
3. Install the transmitter to the wall surface using appropriate screws.

DIN Rail Mounting Kit

A DIN rail mounting kit installs onto the mounting flanges with the provided hardware for mounting the device on a standard DIN rail.

1. Screw the DIN rail brackets onto the flanges using the provided screws.
2. Snap the transmitter into place on a DIN rail.
3. Use the latches on the DIN brackets to release the transmitter from the DIN rail.



Connecting Sensor Probes

pH and ORP or DO sensors are equipped with "BNC" style connectors which push on and then turn 1/4 rotation CW to lock them in place.

Temperature and EC probes have a screw terminal block; make the connections according to the label on the transmitter. The terminal block may be removed for easier wire installation or for service.

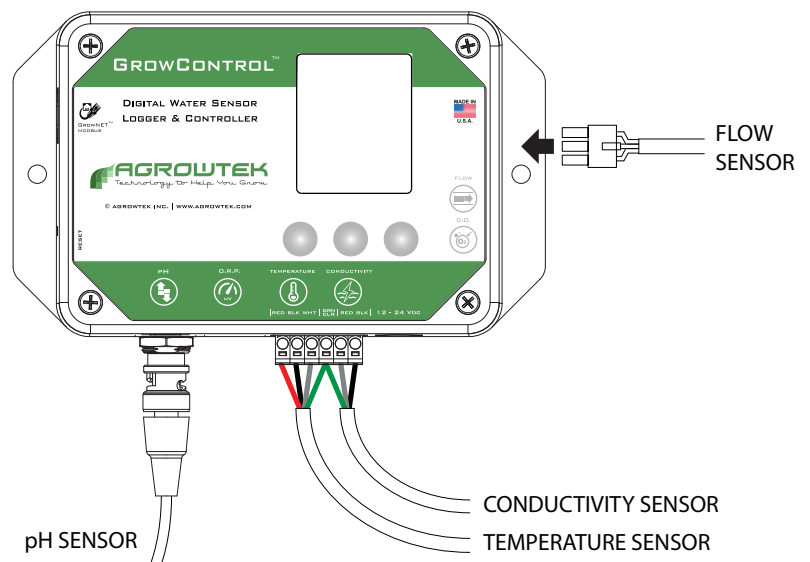

NOTE:

1. Some EC probes may not have a **"clear" wire** and may only have a red and black wire.
2. Temperature probes with **green wire** connect to the "CLR" terminal.

PPX Probe Pontoon

Sensors may be “floated” directly in a water tank using a “probe pontoon” which is designed to keep the probes in contact with the water as the depth changes.

Serpentine shape allows the pontoon to be installed through narrow diameter tank openings.

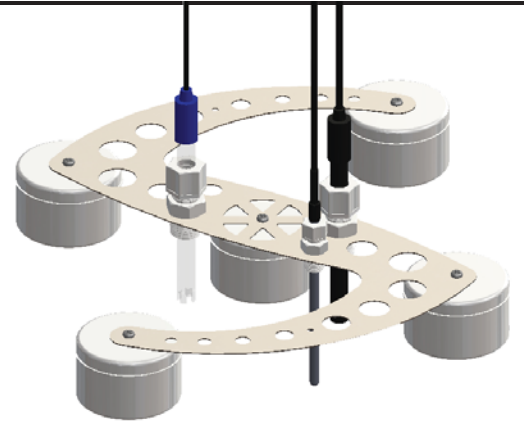

PBX Probe Manifolds

Sensors may be installed “inline” with flow using 1” PBX series probe manifolds. Manifolds include removable compression fittings to seal the probes, and o-ring seals on the manifolds for easy removal during calibration.

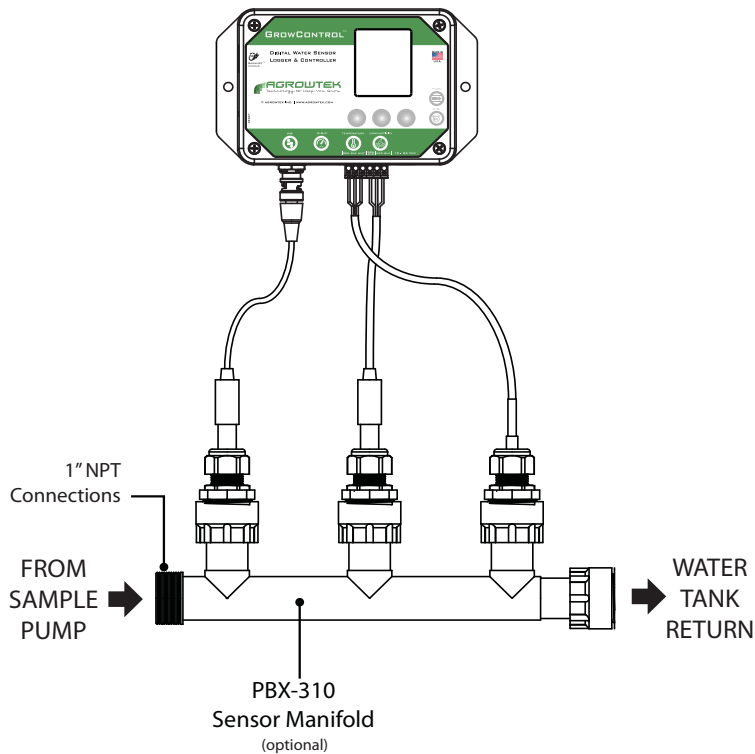
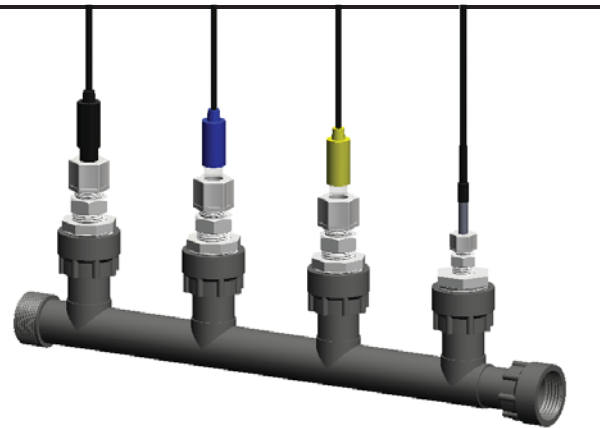

IMPORTANT NOTE: For flow rates above 20 gpm, ensure probe tips are raised out of the flow path to prevent turbulence altering the sensor readings.

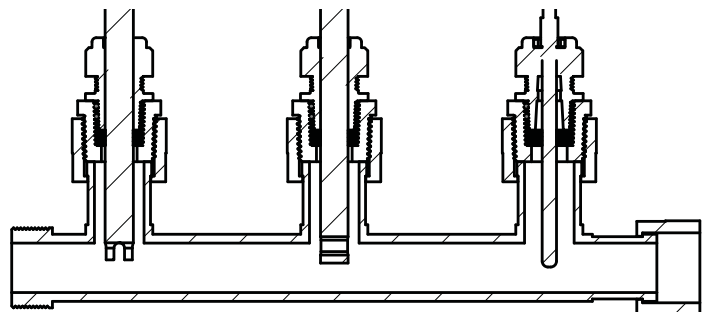

Optional Power Supply

If the SXH will not be connected to a control system with the GrowNET™ RJ-45 jack, the device will need power from the optional external power supply. The external power supply plugs into the DC barrel jack on the bottom of the unit.



Power Supply: 24Vdc 1Amp max

Connection to ADi Pump

When a GCX control system is not present, a direct-link connection between a SXHM sensor and ADi pump is possible with Agrowtek's cross-over adapter between the devices. See 'mini-master' mode configuration.

⚠ IMPORTANT! ONLY use cross-over adapters provided by Agrowtek. Do not use other cross-over adapters or cross-over cables unless they are constructed exactly as diagramed on the cross-over diagram. Incorrect cross-over adapters or cables can cause damage to the equipment.



The SXHM controller will receive power from the ADi pump bank through the RJ-45 cable.

Connection to GrowControl™ GCX

All GrowNET™ devices are connected using standard CAT5 Ethernet cable with RJ-45 connections. Devices can be connected directly to the GrowNET™ ports on the bottom of the controller, or through HX8 GrowNET™ hubs. It is typical to simplify cabling by locating hubs centrally in hall ways and rooms allowing single runs from an 8-port device hub back to a central hub or back to the controller.

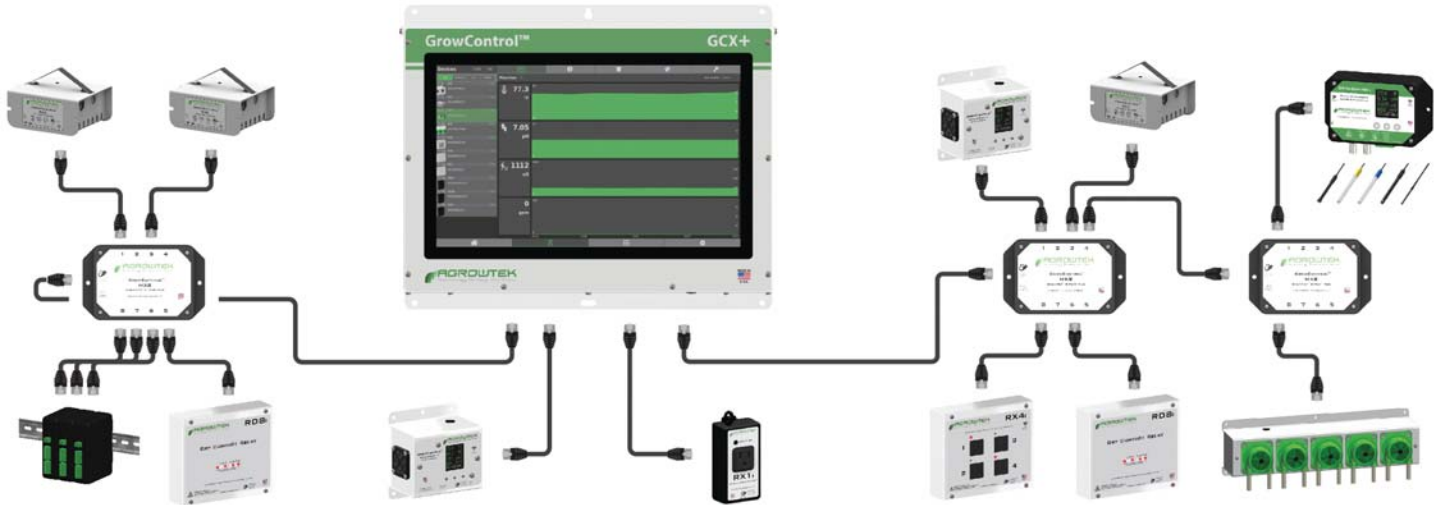

Refer to the GCX controller manual for details on adding the device to the system.

GrowNET™ Hubs

HX8 GrowNET™ hubs expand a single port into eight more ports. Hubs can be daisy-chained to form a network of up to 100 devices per GrowNET™ bus. Individually buffered port transceivers provide excellent signal integrity and extended communication strength and range. Hubs provide up to 1A of power for operating sensors and most relays directly over the CAT5 cable.

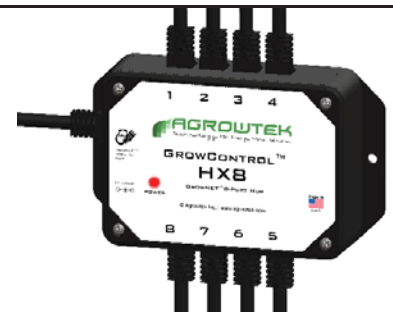

⚠ NOTICE

GrowNET™ ports use standard RJ-45 connections but are NOT compatible the Ethernet network equipment. Do not connect GrowNET™ ports to Ethernet ports or network switch gear.

pH & ORP Probe Preparation

Probe Shipping & Storage

pH & ORP probes are shipped in a plastic bottle containing a solution of pH 4 buffer and potassium chloride. The electrode should remain in the bottle until it is used.

If the electrode is used infrequently, the bottle and its solution should be saved and the electrode stored in it. If the solution in the soaker bottle is missing, fill the bottle with pH 4 buffer.

Take out electrode by loosening plastic top on bottle counter-clockwise and pulling electrode out. Slide cap and O-ring off electrode and save.

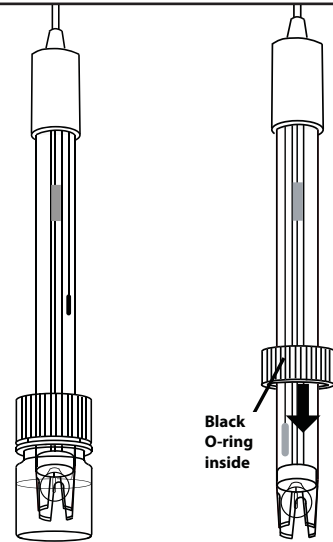

Air Bubble

During shipment the air bubble in the electrode's stem may move into the bulb area.

If bubbles are seen in the bulb area, hold the electrode by its top cap and shake while pointed downward.

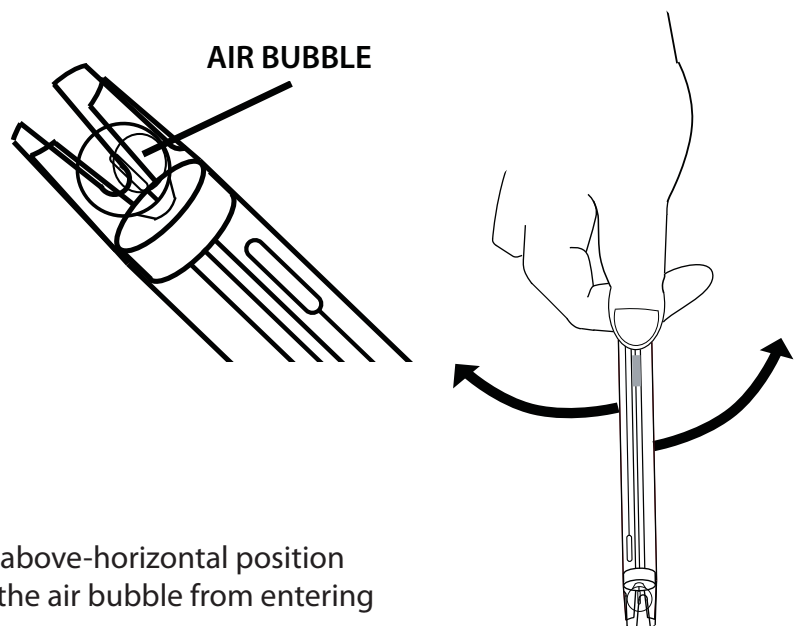

⚠ Installation/Operation Angle

pH & ORP sensor probes must be installed in an above-horizontal position with the probe tip facing downward to prevent the air bubble from entering the the bulb area.

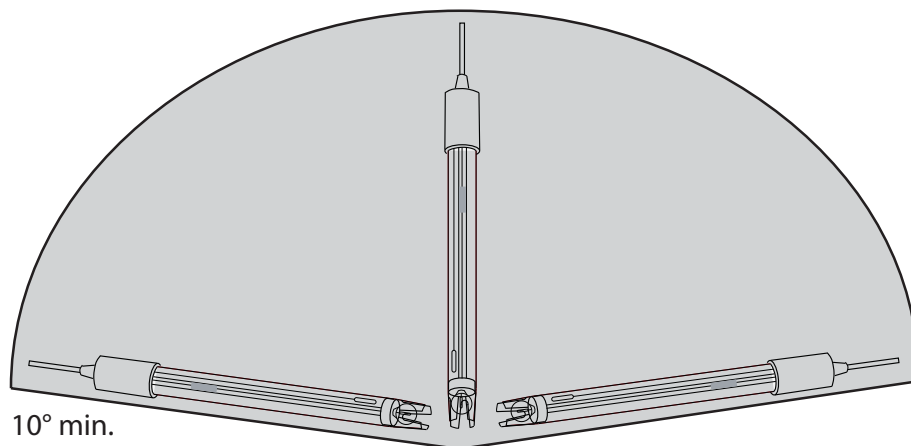

⚠ pH & ORP probes must remain wet to avoid damage. Do not allow probe tips to dry.

LCD Menu Operation Instructions

SXHM models with the optional 3-button/LCD display interface may be used for stand-alone monitoring applications or as part of a control solution.

Connect to Agrowtek's GrowControl facility control systems, or directly to Agrowtek's AgrowDose pumps for automatic nutrient and pH control.



The main screen displays the real-time sensor readings from the attached sensors. Each button is labeled at the bottom of the display to describe its function on the current screen or menu.

High / Low History

H/L

Simple minimum and maximum recorded values are stored until the user resets the values to the current readings. To view the minimum and maximum values since the last reset, press the button labeled **H/L**.

To clear the min/max history, press the **RST** button to reset. The min and max values will all be set to the current readings and will update with higher or lower readings as they occur.

LOW	HIGH	
68.4	72.0	°F
4.21	4.85	pH
551	657	uS
404	480	mV

EXIT **RST**

Graphing

GPH

The display can graph the most recent 120 data points from the sensor's internal data point memory. With the default logging interval of 60 seconds, the graph displays the last two hours of data.

The sensor value is plotted in green. Temperature, if overlaid on the plot, is red. Alarm levels as set by the user are plotted in yellow. Pressing the **RFH** button refreshes the data and replots the graph.

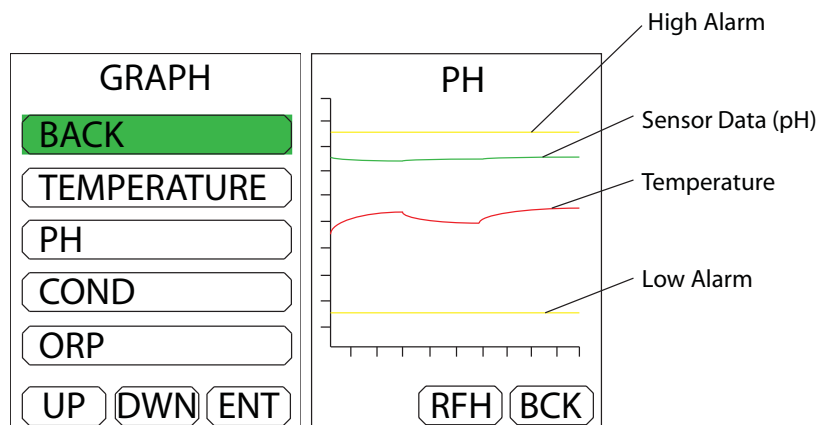

Main Menu

MNU

The main menu is how the alarms are set, sensors are calibrated and general settings such as time, date and units are configured.

If a dosing pump is directly connected to the SXHM GrowNET port, the pump settings are also accessed by the main menu.

Use the UP or DWN buttons to navigate the menu.

Use the ENT button to enter a selection.

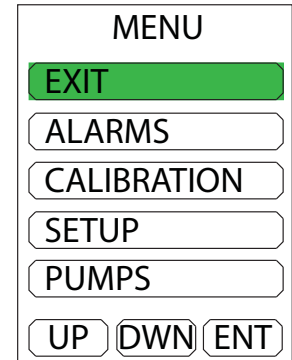

Alarms Menu

MNU ► ALARMS

High and low alarm set points may be configured for each sensor value to activate an internal buzzer or send alerts with the optional wifi module.

The out-of-range value will be displayed in red to indicate the cause for the alarm.

Additionally, alarm limits are plotted on the graphs to indicate values are within the desired range.

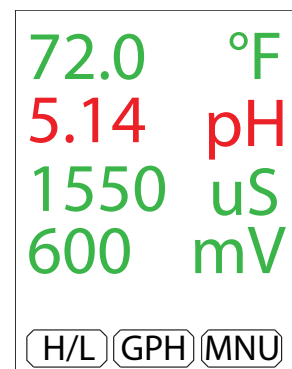

Alarms Configuration

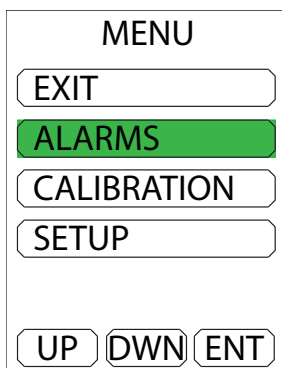

1. Select **ALARMS** from the main menu.

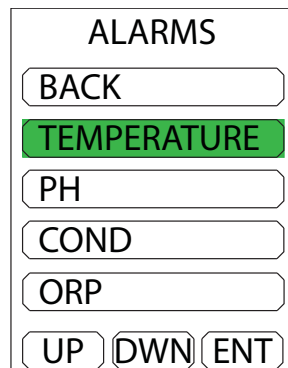

2. Select a sensor to configure set points.

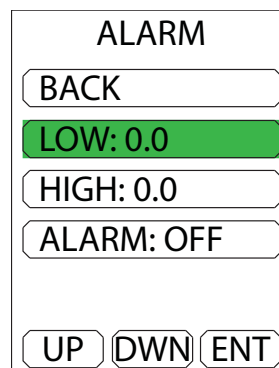

3. Select the setting to adjust.

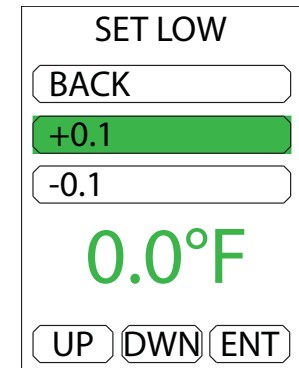

4. Adjust to the desired value. Hold UP or DWN to jog the value.

Alarm Buzzer

ALARM

BACK

LOW: 0.0

HIGH: 0.0

ALARM: OFF

UP DWN ENT

1. Select **ALARM: OFF**

SET ALARM

BACK

SET ON

SET OFF

OFF

UP DWN ENT

2. Select **SET ON** then press **BACK** to exit.

To disable the alarm buzzer, set the alarm to OFF.

Calibration Menu

MNU ► CALIBRATION

Calibration can be performed for each sensor with the LCD interface using either standard calibration wizards, or advanced manual calibration methods for non-standard calibration solutions.

The date of the last calibration for each sensor is stored in memory and displayed at the start of each calibration wizard.

MENU

EXIT

ALARMS

CALIBRATION

SETUP

UP DWN ENT

CALIBRATION

BACK

TEMPERATURE

PH

COND

CLEAR ALL

UP DWN ENT

Clear Calibration

MNU ► CALIBRATION ► NEXT

Calibration can be restored to factory defaults by selecting **CLEAR ALL**.

CALIBRATION

BACK

TEMPERATURE

PH

COND

CLEAR ALL

UP DWN ENT

1. Select **CLEAR ALL** from the calibration menu.

RESTORE TO
FACTORY
CALIBRATION?

YES NO

2. Press **YES** to restore factory calibration.

Temperature Calibration

MNU ► CALIBRATION ► TEMPERATURE

CALIBRATION

BACK

CALIBRATE

ADVANCED

UP DWN ENT

1. Select **CALIBRATE** from calibration menu.

TEMPERATURE

LAST CALIBRATION
10/19/2017

PRESS NEXT TO
ADJUST
TEMPERATURE
READING.

EXIT NEXT

2. Press **NEXT** to continue.

OFFSET

BACK

+0.1

-0.1

72.2°F

UP DWN ENT

3. Adjust to the desired value. Hold **ENT** to jog the value by 10x.

CONFIRM?

OLD
68.1 °F

NEW
72.2 °F

YES NO

4. Confirm the new reading or press **NO**.

pH Calibration

MNU ► CALIBRATION ► PH

pH calibration is a two-point process requiring both pH 7 and pH 4.01 calibration solutions. The temperature probe must be inserted into the calibration solution at the same time as the pH probe.

CALIBRATION

BACK

CALIBRATE

ADVANCED

UP DWN ENT

1. Select **CALIBRATE** from calibration menu.

PH

LAST CALIBRATION
10/19/2017

STEP 1:
PUT TEMPERATURE
AND PH PROBE IN
PH7 SOLUTION.

EXIT NEXT

2. Follow the instructions then press **NEXT**.

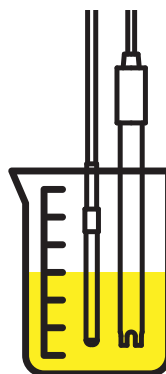

pH 7 Calibration Solution

PH

7.12 pH

WAIT FOR READING
TO STABILIZE THEN
PRESS NEXT.

EXIT NEXT

3. When the reading is stable, press **NEXT**.

PH

7.00 pH

STEP 2:
PUT TEMPERATURE
AND PH PROBE IN
PH4.01 SOLUTION.

EXIT NEXT

4. Clean the probes with DI/RO and change calibration solution.

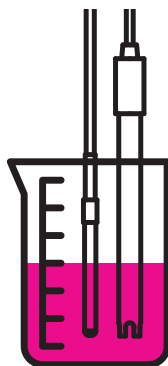

pH 4.01 Calibration Solution

PH

4.14 pH

WAIT FOR READING
TO STABILIZE THEN
PRESS DONE.

EXIT DNE

5. When the reading is stable, press **DONE** to calibrate pH 4.01 and finish calibration.

Conductivity Calibration

MNU ► CALIBRATION ► COND

Conductivity calibration is a single point process requiring 1413 uS calibration solution. The temperature probe must be inserted into the calibration solution at the same time as the conductivity probe.

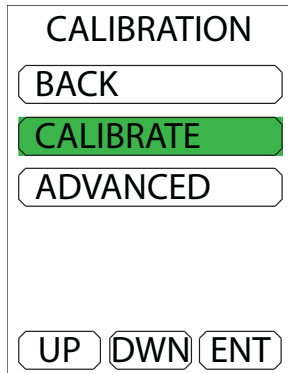

1. Select **CALIBRATE** from the conductivity calibration menu.

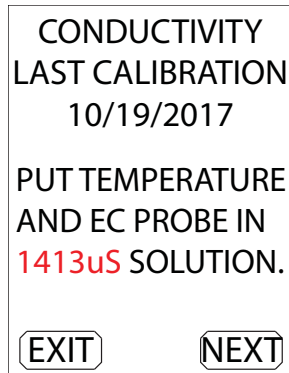

2. Follow the instructions then press **NEXT** to continue.

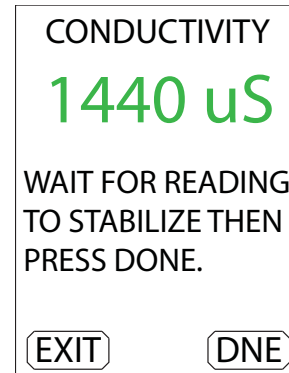
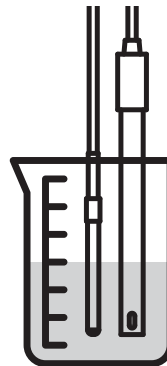

3. When the reading is stable, press **DONE** to complete the calibration.

O.R.P. Calibration

MNU ► CALIBRATION ► NEXT ► ORP

ORP (optional) calibration is a single point process requiring 470 mV calibration solution.

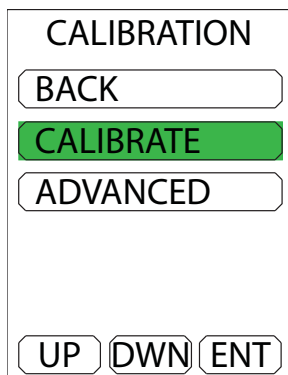

1. Select **CALIBRATE** from the conductivity calibration menu.

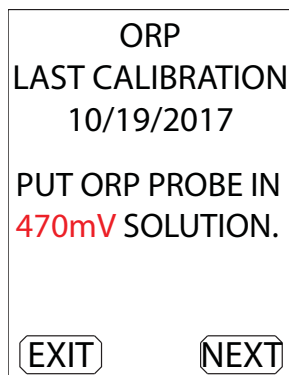

2. Follow the instructions then press **NEXT** to continue.

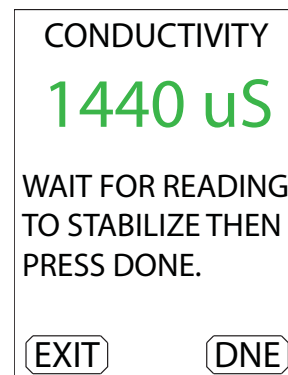
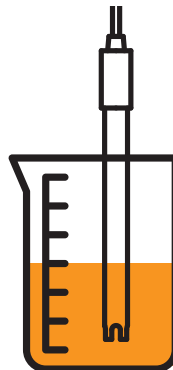

3. When the reading is stable, press **DONE** to complete the calibration.

Advanced Calibration

Sensors values may be manually calibrated to alternate standards using the advance calibration features.

OFFSET calibration applies a linear offset adjustment to the value.
SPAN calibration applies an adjustment to the slope of the sensor value.

Note: pH and conductivity are temperature compensated (ATC) sensors. For accurate calibration, the temperature probe must be in the pH and conductivity calibration standards. Allow all readings to stabilize before performing an offset or span calibration operation.

CALIBRATION
BACK
CALIBRATE
ADVANCED
UP DWN ENT

PH

CAL 7 sets the pH 7 calibration (offset.) Cal 7 automatically clears span calibration point prior performing pH 7 calibration.

SPAN calibration is performed typically at pH 4.01 or 10.0 (*Always perform pH 7 calibration first.*)

CONDUCTIVITY

SET CAL 0 calibrates a dry EC probe if required. (not recommended)

SPAN calibration is recommended at 1413uS. If using ppm standards, ensure the display is in the correct units.

DISSOLVED OXYGEN (D.O.)

OFFSET calibration is recommended in zero oxygen solution.

SPAN calibration is recommended at a known DO level or in air.

OXIDATION REDUCTION POTENTIAL (O.R.P.)

OFFSET is recommended at 270mV

SPAN is recommended at 470mV

Analog Output Calibration

4-20mA analog outputs may also be calibrated with a positive or negative offset to compensate for variation in DAC's/ADC's. The sensors' current output may be incrementally increased or decreased in steps of 0.005mA over a range of +/-2mA.

1 Offset bit = 0.005mA, Range = +/-400 bits (+/-2mA)

This calibration procedure is optional and only for use with custom PLC applications.

1. Observe the PLC's input or data readings.
2. Increase or decrease the offset value to incrementally adjust the current output until the values match.

ANALOG
BACK
+1
-1
-5
UP DWN ENT

Setup Menu

MNU ► SETUP

The setup menu is where the time and date are set, the units are configured, logging interval is adjusted and advanced communications settings are available.

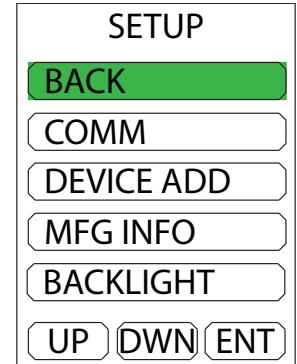
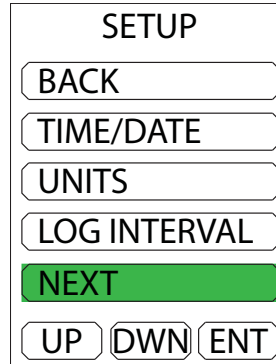

Time / Date

MNU ► SETUP ► TIME/DATE

Sensors include a precision real-time clock with battery back-up for time-stamping the data log information with the time and date. The last calibration for each sensor is also time stamped.

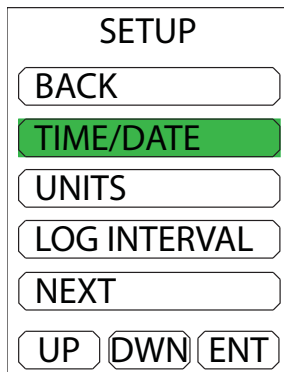

1. Select **TIME/DATE** from the setup menu.

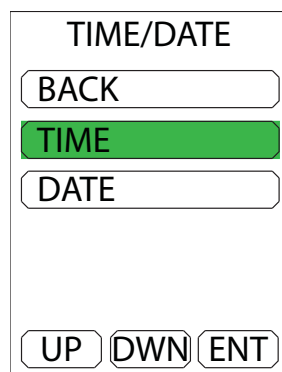

2. Select **TIME** or **DATE** to adjust.

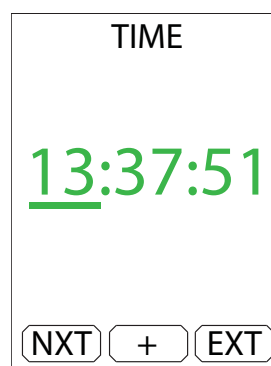

3. Use **NXT** to select the value to adjust. Use **+** to increment the value.

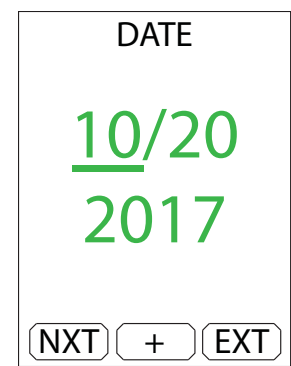

4. Use **EXT** to exit the menu.

Units

MNU ► SETUP ► UNITS

Temperature and Conductivity may be displayed in alternate units.

Select a sensor value to change the default display and working units.

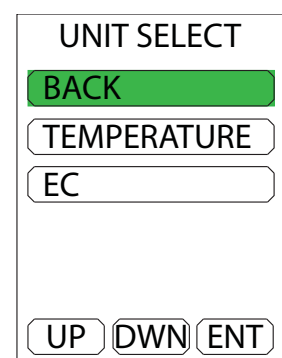
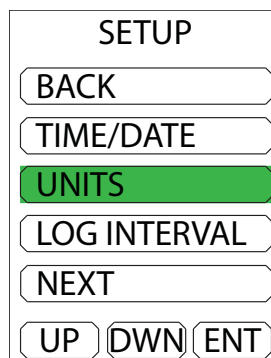

Configure temperature units:

Temperature may be displayed in °F or °C.

Note: Check alarm settings when converting temperature units.

UNIT SELECT

BACK

TEMPERATURE

EC

UP DWN ENT

1. Select **TEMPERATURE** from the units menu.

UNIT SELECT

BACK

°C

°F

68.0°F

UP DWN ENT

2. Select the desired units and press **ENT**.

Configure conductivity units:

Conductivity may be displayed in default units of microSiemens (uS) or total dissolved solids in parts per million (ppm.)

The TDS conversion factor used by this meter is 500.

$$\text{TDSppm} = \text{uS} \times 0.5$$

UNIT SELECT

BACK

TEMPERATURE

EC

UP DWN ENT

1. Select **EC** from the units menu.

UNIT SELECT

BACK

US

TDS

654 ppm

UP DWN ENT

2. Select the desired units and press **ENT**.

Logging Interval

MNU ► SETUP ► LOG INTERVAL

Adjust the interval for recording data points in the on-board memort. Acceptable values are from 1 - 65535 seconds.

21,600 data points can be stored for each sensor value. The most recent 120 data points are shown on the graphical history.

The entire data history may be downloaded from the sensor to a .csv file with the LX1 USB AgrowLINK and free software.

Note: 60 second intervals = 15 days of data storage.

SETUP

BACK

TIME/DATE

UNITS

LOG INTERVAL

NEXT

UP DWN ENT

1. Select **LOG INTERVAL** from the setup menu.

LOGGIN INTERVAL

BACK

+1

-1

60 SEC

UP DWN ENT

2. Adjust the value then select **BACK**.

COMM Mode

MNU ► SETUP ► NEXT ► COMM

COMM mode specifies whether the sensor is a normal passive device or “mini-master” device.

NORMAL Use with GrowControl master controller systems or stand-alone and data logging applications.

MINI-MASTER Use with MDX mini-dosing system. (GrowNET cross-over adapter required.)

SETUP

BACK

COMM

DEVICE ADD

MFG INFO

UP DWN ENT

1. Select **COMM** from the setup menu.

COM MODE

NORMAL

MINI MASTER

UP DWN ENT

2. Select a mode and press **ENT**.

Device Address

MNU ► SETUP ► NEXT ► DEVICE ADD

Sensors are digitally addressable from 1-249 and will be assigned an address automatically by Agrowtek’s control systems, or can be configured manually for MODBUS applications via the menu.

NOTE: All of Agrowtek’s devices use address 254 as a broadcast address.

SETUP

BACK

COMM

DEVICE ADD

MFG INFO

BACKLIGHT

UP DWN ENT

1. Select **DEVICE ADD** from the setup menu.

DEVICE ADDRESS

BACK

+1

-1

0 Addr

UP DWN ENT

2. Adjust the value then select **BACK**.

Manufacturing Info

MNU ► SETUP ► NEXT ► MFG INFO

Manufacturer information such as serial number, date of manufacture, hardware and firmware versions can be read from the MFG INFO page.

SETUP

BACK

COMM

DEVICE ADD

MFG INFO

BACKLIGHT

UP DWN ENT

1. Select **MFG INFO** from the setup menu.

SERIAL NUMBER:
17090554
DATE OF MFG:
09/15/17
HW VERSION:
C
FW VERSION:
02.03.84

EXIT

2. Press **EXIT** to return.

Display Back Light Timer

MNU ► SETUP ► NEXT ► BACKLIGHT

The display back light can be programmed to turn off after a specified time of inactivity from the last time a button is pressed.

The delay can be set from 1-255 minutes, or set to 0 to disable the back light timer and keep the display on continuously.

SETUP

BACK

COMM

DEVICE ADD

MFG INFO

BACKLIGHT

UP DWN ENT

BACKLIGHT

BACK

+1

-1

60 Min

UP DWN ENT

Connection to 4-20mA Outputs

Converting sensors to current output requires the LX4 4-20mA Analog Module.

The LX4 module will convert any Agrowtek GrowNET™ sensor device into an analog output signal for 4-20mA PLC inputs. The LX4 features four channels of output for sensors with up to four values. Simply plug into the Agrowtek device and the LX4 will begin transmitting sensor data. See LX4 manual for more detail.

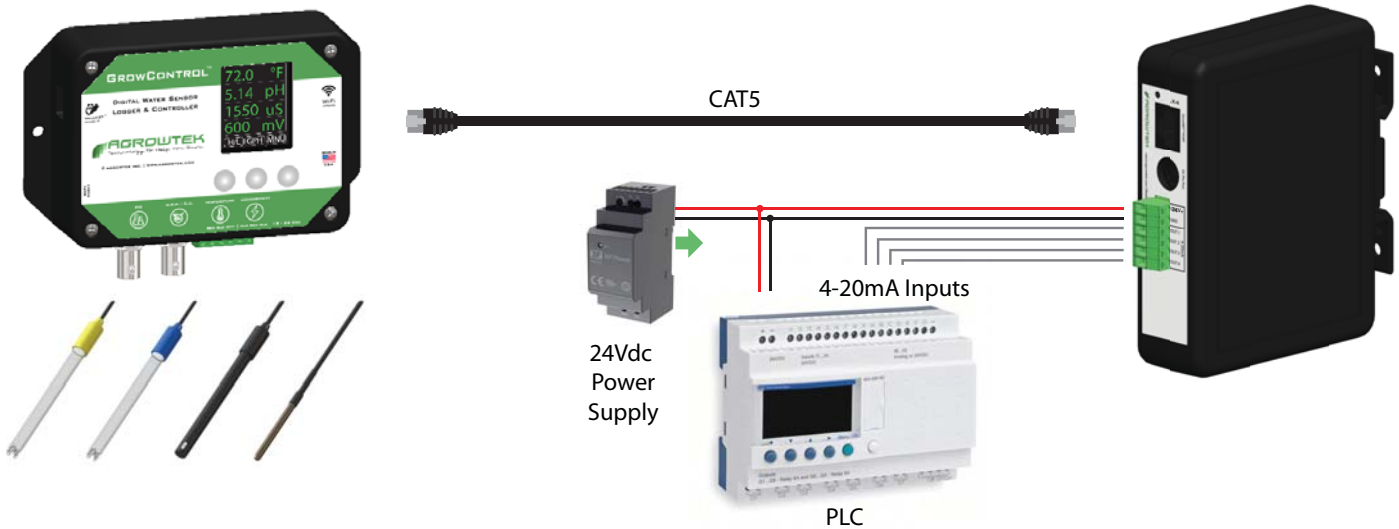

Connection to USB AgrowLINK

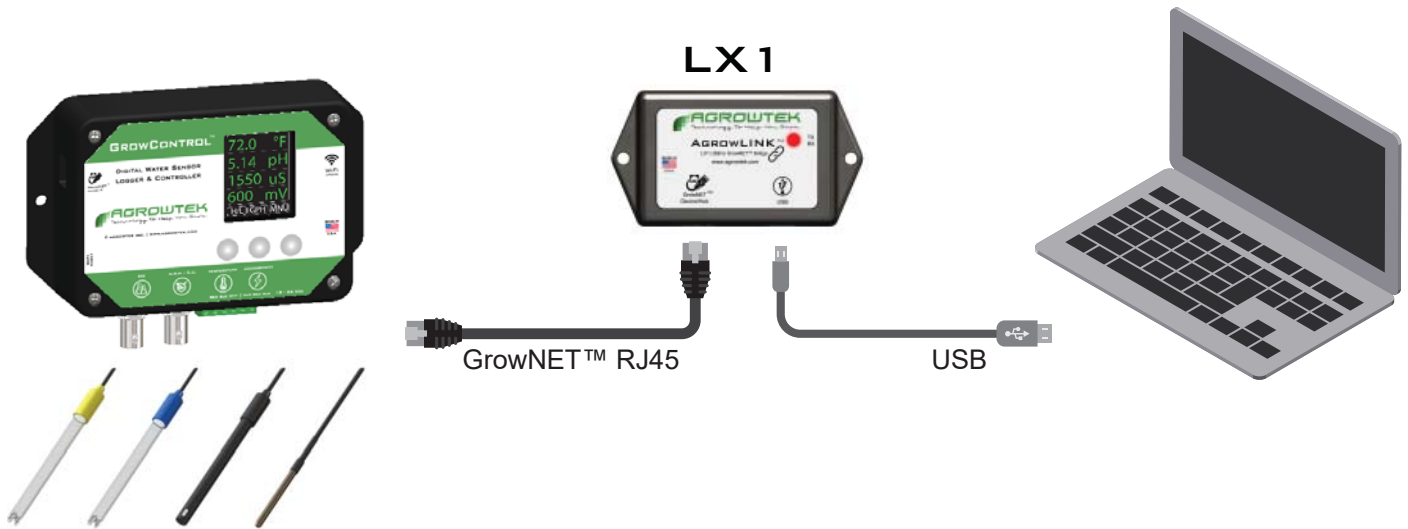

LX1 USB AgrowLINK connects Agrowtek's devices to a computer's USB port for:

- Firmware Updates
- Calibration
- Configuration
- Data Logging Download
- More

Connection to MODBUS RTU

RS-485

Use the LX2 ModLINK to connect MODBUS devices to the GrowNET™ port.

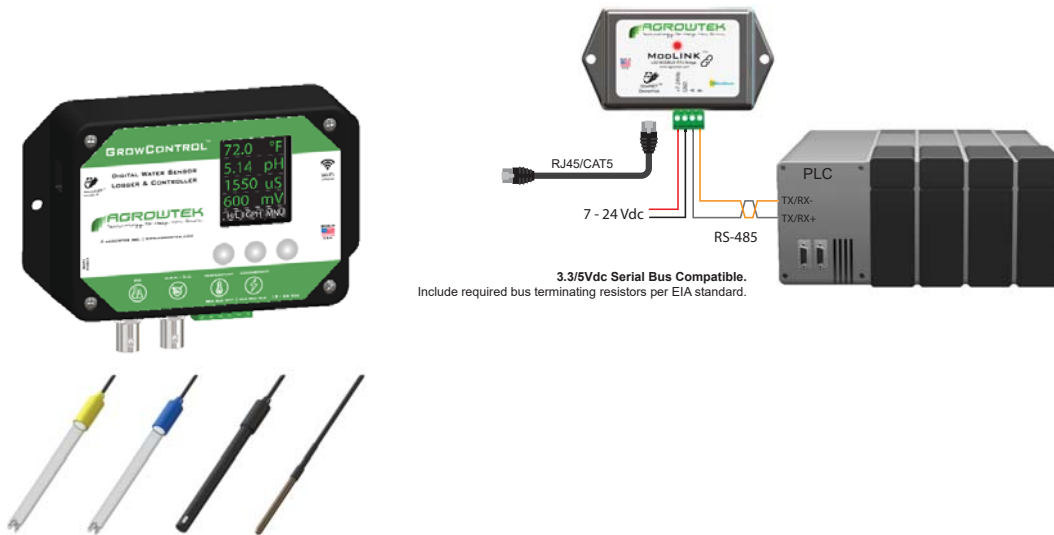

Serial Speed & Format

The default serial data format for the LX2 ModLINK interface is: **19,200 baud, 8-N-1.**

Alternate speeds and formats between 9,600 - 115,200 baud may be configured with the free AgrowLINK PC utility using a LX1 USB AgrowLINK and the cross-over adapter supplied with the LX2 ModLINK.

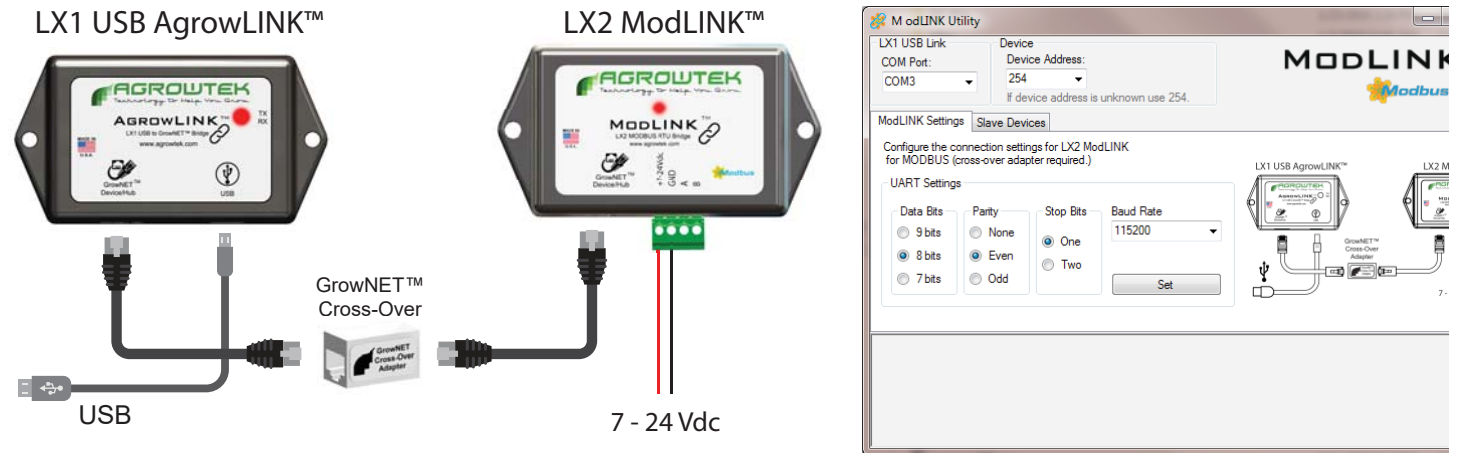

See MODBUS manual for more information.

 [MODBUS Manual](#)

Supported Commands

0x03 Read Multiple Registers
0x06 Write Single Register

A request to use a function that is not available will return an illegal function exception.

Register Types

All registers are 16 bits wide with addresses using the standard MODICON protocol. Floating point values use the standard IEEE 32-bit format occupying two contiguous 16 bit registers. ASCII values are stored with two characters (bytes) per register in hexadecimal format.

Sensor Value Registers

Sensor values are available in integer or floating point formats depending on the register requested (see map.)

Sensor #	Type	Integer Scale	Range
1	Temperature	x100	-2000 - 6000 (-20 - 60°C) / -400 - 14000 (-4 - 140°F)
2	pH	x100	0 - 1400 (0 - 14.00pH)
3	Conductivity	x1	0 - 5000 microSiemens
4	O.R.P.	x1	-1000 - +1000 mV
	D.O.	x100	0 - 4000 (0 - 40.00 mg/L max, per cal)

For example: an integer temperature value of 2417 is equal to a temperature reading of 24.17°C.

Calibration Registers

Calibration registers are 16-bit signed integers for the purpose of calibrating the sensor values or analog output channels. Calibration may be achieved by writing the desired calibrated value to the associated register. Writing to the calibration registers automatically invokes the calibration routine for that register.

Zero (Offset) Calibration

Zero calibration is an arithmetic positive or negative correction to the sensor reading.

Operations performed using the offset register are:

- Temperature calibration
- pH 7 calibration
- Conductivity, ORP or DO zero calibration

To perform a sensor offset calibration, simply write the corrected sensor value to the offset calibration register (taking into account the integer scaling.)

To set the temperature to a calibrated value of 25°C, write the value "2500."

To set the pH 7 calibration, write the value "700."

To set the conductivity zero calibration, write the value "0."

Span Calibration

Span, or slope calibration, corrects the slope of the sensor reading at a second point, away from the zero calibration. Operations performed using the span register are:

- pH 4.01 or 10.0 calibration
- Conductivity, ORP or DO calibration to solution standard

To set the pH 4.01 calibration, write the value "401."

To set the conductivity to a calibrated value of 1413uS, write the value "1413."

Note: perform any "zero" calibrations prior span calibrations.

Analog Calibration

Analog output calibration sends a positive or negative offset to the respective output channel's digital to analog converter (DAC.) The DAC has a resolution of 0.005mA/bit.

± 1 calibration bit = ± 0.005 mA adjustment

For example: to shift the analog output up by 0.1 mA, set the analog offset value to +20. ($0.1 / 0.005 = 20$)

Reset Calibration to Factory

To reset all calibration values, write a "1" value to the clear calibration register.

MODBUS Holding Registers

Parameter	Description	Range	Type	Access	Address
Address	Device Slave Address	1 - 247	8 bit	R/W	40001
Serial#	Device Serial Number	ASCII	8 char	R	40004
DOM	Date of Manufacture	ASCII	8 char	R	40008
HW Version	Hardware Version	ASCII	8 char	R	40012
FW Version	Firmware Version	ASCII	8 char	R	40016
Toggle Units	Toggle sensor units	1 - 4	16 bit, unsigned	W	41002
Sensor Reading, Integer	Temperature	-2000 - 6000 (-20 - 60°C)	16 bit, signed	R	40101
	pH	0 - 1400 (0 - 14.00pH)			40102
	Conductivity	0 - 5000 microSiemens 0 - 2500 ppm			40103
	O.R.P. / D.O.	-1000 - +1000 mV 0 - 4000 (0 - 40.00 mg/L)			40104
Sensor Reading, Float	Temperature	-20.00- 60.00 °C	32 bit, floating pt	R	40201
	pH	0 - 14.00pH			40203
	Conductivity	0 - 5000 microSiemens 0 - 2500 ppm			40205
	O.R.P. / D.O.	-1000 - +1000 mV 0 - 4000 (0 - 40.00 mg/L)			40207
Calibration Input, Zero	Temperature	See integer ranges above.	16 bit, signed	W	41101
	pH				41102
	Conductivity				41103
	O.R.P. / D.O.				41104
Calibration Input, Span Point	Temperature	See integer ranges above.	16 bit, signed	W	41201
	pH				41202
	Conductivity				41203
	O.R.P. / D.O.				41204
Calibration Input, Analog Output	Temperature	-255 - 255 (bits)	16 bit, signed	W	41301
	pH				41302
	Conductivity				41303
	O.R.P. / D.O.				41304
Clear Calibration	Reset All to Factory Default	Signed Int	16 bit	W	41401

A request to read or write a register that is not available will return an illegal address exception.

Maintenance

Sensor probes require periodic cleaning, reconditioning and calibration for reliable service. See calibration section for details on performing calibration service after cleaning.

Probe Cleaning

Coating of the pH or ORP bulbs can lead to erroneous readings including shortened span (slope). Coatings and blockages in the EC sensor can cause incorrect readings. The type of coating will determine the cleaning technique.

Soft coatings can be removed by vigorous stirring or by the use of a squirt bottle.

Organic chemical or hard coatings should be chemically removed. 5-10% hydrochloric acid (HCl) soak for a few minutes and often removes many coatings.

If cleaning does not restore pH sensor performance, reconditioning may be tried.

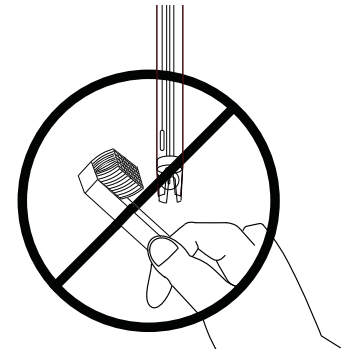

Do not use a brush or abrasive on pH or EC probes.

pH Probe Reconditioning

When reconditioning is required due to electrode aging the following chemical treatments can be tried. They are presented in the order of the severity of attack on the pH glass and may not improve (and in some cases actually further deteriorate) electrode performance.

⚠ DANGER: Use proper precautions when handling these hazardous chemicals. Ammonium bifluoride and HF (hydrofluoric acid) are extremely hazardous and should only be used by qualified personnel.

Reconditioning Method 1

Immerse the electrode tip in 0.1 N HCl for 15 seconds, rinse in tap water and then immerse tip in 0.1 M NaOH for 15 seconds and rinse in tap water. Repeat this sequence three times and then recheck the electrode's performance. If performance has not been restored, try method two.

Reconditioning Method 2

Immerse the tip in a 20% solution of NH₄F-HF (ammonium bifluoride) for two to three minutes, rinse in tap water and recheck performance. If performance has not been restored, try method three.

Reconditioning Method 3

Immerse electrode tip in 5% HF for 10-15 seconds, rinse well in tap water, quickly rinse in 5N HCl, rinse well in tap water and recheck performance. If performance has not been restored, it is time to get a new probe.

Warranty

Agrowtek Inc. warrants that all manufactured products are, to the best of its knowledge, free of defective material and workmanship and warrants this product for one (1) year from the date of purchase. This warranty excludes consumables (sensor probes) which are limited to a 120 day warranty period against defects. This warranty is extended to the original purchaser from the date of purchase. Returns not purchased directly from Agrowtek Inc. must include proof of purchase date otherwise purchase date is considered as date of manufacture. This warranty does not cover damages from abuse, accidental breakage, or items that have been modified, altered, or installed in a manner other than that which is specified in the installation instructions. This warranty is applicable only to products that have been properly stored, installed, and maintained per the installation and operation manual and used for their intended purpose. This limited warranty does not cover products installed in or operated under unusual conditions or environments including, but not limited to, excessive humidity or extreme temperature conditions outside of the specified limits. Agrowtek Inc. must be contacted prior to return shipment of any returns for a return authorization. No returns will be accepted without a return authorization. Customer is responsible for return shipment to Agrowtek Inc. for warranty service. Return authorization number(s) must be printed on the outside of the box or the return may be rejected and returned to the sender. Agrowtek Inc. is not responsible for supplying replacement products or parts in advance of return(s) for warranty claim. The products which have been claimed and comply with the aforementioned restrictions shall be replaced or repaired at the sole discretion of the Agrowtek Inc. at no charge. This warranty is provided in lieu of all other warranty provisions, express or implied. It is including but not limited to any implied warranty of fitness or merchantability for a particular purpose and is limited to the Warranty Period. In no event or circumstance shall Agrowtek Inc. be liable to any third party or the claimant for damages in excess of the price paid for the product, or for any loss of use, inconvenience, commercial loss, loss of time, lost profits or savings or any other incidental, consequential or special damages arising out of the use of, or inability to use, the product. This disclaimer is made to the fullest extent allowed by law or regulation and is specifically made to specify that the liability of Agrowtek Inc. under this limited warranty, or any claimed extension thereof, shall be to replace or repair the Product or refund the price paid for the Product.