LHT65N LoRaWAN Temperature & Humidity Sensor Manual

last modified by Mengting Qiu

on 2025/02/26 13:58

Table of Contents

1. Introduction	6
1.1 What is LHT65N LoRaWAN Temperature & Humidity Sensor	6
1.2 Features	6
1.3 Specification	7
2. Connect LHT65N to IoT Server	7
2.1 How does LHT65N work?	7
2.2 How to Activate LHT65N?	7
2.3 Example to join LoRaWAN network	8
2.3.1 Step 1: Create Device on TTN	9
2.3.2 Step 2: Add decoder	10
2.3.3 Step 3: Activate LHT65N by pressing the ACT button for more than 5 seconds.	11
2.4 Uplink Payload (Fport=2)	11
2.4.1 Decoder in TTN V3	11
2.4.2 BAT-Battery Info	12
2.4.3 Built-in Temperature	13
2.4.4 Built-in Humidity	13
2.4.5 Ext #	13
2.4.6 Ext value	13
2.5 Show data on Datacake	21
2.6 Datalog Feature	23
2.6.1 Ways to get datalog via LoRaWAN	24
2.6.2 Unix TimeStamp	24
2.6.3 Set Device Time	25
2.6.4 Poll sensor value	26
2.6.5 Datalog Uplink payload	26
2.7 Alarm Mode & Feature "Multi sampling, one uplink"	28
2.7.2 ALARM MODE (Before v1.3.1 firmware)	29
2.8 LED Indicator	30
2.9 installation	30
3. Sensors and Accessories	31
3.1 E2 Extension Cable	31
3.2 E3 Temperature Probe	31
3.3 E31F Temperature Probe	32
3.4 NE117 Temperature Probe (Model: LHT65N-NE117)	33
3.5 Dry Contact Probe (Model: LHT65N-DC)	33
3.6 Door Sensor (Model: LHT65N-DS)	35
3.6 NIS Certificate Probe (Model: LHT65N-NIS)	35
4. Configure LHT65N via AT command or LoRaWAN downlink	36
4.1 Set Transmit Interval Time	37
4.2 Set External Sensor Mode	37
4.3 Enable/Disable uplink DS18B20 Temperature probe ID	37
4.4 Set Password	38
4.5 Quit AT Command	38
4.6 Set to sleep mode	38
4.7 Set system time	39
4.8 Set Time Sync Mode	39
4.9 Set Time Sync Interval	39
4.10 Get data	39
4.11 Print data entries base on page	40
4.12 Print last few data entries	40
4.13 Clear Flash Record	40
4.14 Auto Send None-ACK messages	41

User Manual for LoRaWAN /NB -IoT End Nodes - LHT65N
LoRaWAN Temperature & Humidity Sensor Manual

4.15 Modified WMOD command for external sensor TMP117 or DS18B20 temperature alarm(Since firmware 1.3.0)	41
4.16 Get Firmware Version Info(Since V1.4.0)	42
4.17 Setting LEDAlarm	43
5. Battery & How to replace	43
5.1 Battery Type	43
5.2 Replace Battery	44
5.3 Battery Life Analyze	44
6. FAQ	45
6.1 How to connect to LHT65N UART interface?	45
6.3 How to use Downlink commands?	50
6.4 How to change the uplink interval?	53
6.5 How to upgrade firmware?	54
6.5.1 Burning firmware before V1.3 (including V1.3)	55
6.5.2 Updated firmware for V1.4 and above	56
6.6 Why can't I see the datalog information	60
6.7 How can i read sensor data without LoRaWAN? For Calibration Purpose	60
7. Order Info	61
8. Packing Info	61
9. Reference material	61
10. FCC Warning	61



Table of Contents:

- [1. Introduction](#)
 - [1.1 What is LHT65N LoRaWAN Temperature & Humidity Sensor](#)
 - [1.2 Features](#)
 - [1.3 Specification](#)

- [2. Connect LHT65N to IoT Server](#)
 - [2.1 How does LHT65N work?](#)
 - [2.2 How to Activate LHT65N?](#)
 - [2.3 Example to join LoRaWAN network](#)
 - [2.3.1 Step 1: Create Device on TTN](#)
 - [2.3.2 Step 2: Add decoder](#)
 - [2.3.3 Step 3: Activate LHT65N by pressing the ACT button for more than 5 seconds.](#)
 - [2.4 Uplink Payload \(Fport=2\)](#)
 - [2.4.1 Decoder in TTN V3](#)
 - [2.4.2 BAT-Battery Info](#)
 - [2.4.3 Built-in Temperature](#)
 - [2.4.4 Built-in Humidity](#)
 - [2.4.5 Ext #](#)
 - [2.4.6 Ext value](#)
 - [2.4.6.1 Ext=1, E3 Temperature Sensor](#)
 - [2.4.6.2 Ext=9, E3 sensor with Unix Timestamp](#)
 - [2.4.6.3 Ext=6, ADC Sensor\(use with E2 Cable\)](#)
 - [2.4.6.4 Ext=2 TMP117 Sensor\(Since Firmware v1.3\)](#)
 - [2.4.6.5 Ext=11 SHT31 Sensor \(Since Firmware v1.4.1\)](#)
 - [2.4.6.6 Ext=4 Interrupt Mode\(Since Firmware v1.3\)](#)
 - [2.4.6.7 Ext=8 Counting Mode\(Since Firmware v1.3\)](#)
 - [2.4.6.8 Ext=10, E2 sensor \(TMP117\)with Unix Timestamp\(Since firmware V1.3.2\)](#)
 - [2.5 Show data on Datacake](#)
 - [2.6 Datalog Feature](#)
 - [2.6.1 Ways to get datalog via LoRaWAN](#)
 - [2.6.2 Unix TimeStamp](#)
 - [2.6.3 Set Device Time](#)
 - [2.6.4 Poll sensor value](#)
 - [2.6.5 Datalog Uplink payload](#)
 - [2.7 Alarm Mode & Feature "Multi sampling, one uplink"](#)
 - [2.7.1 ALARM MODE \(Since v1.3.1 firmware\)](#)
 - [2.7.2 ALARM MODE \(Before v1.3.1 firmware\)](#)
 - [2.8 LED Indicator](#)
 - [2.9 installation](#)
- [3. Sensors and Accessories](#)
 - [3.1 E2 Extension Cable](#)
 - [3.2 E3 Temperature Probe](#)
 - [3.3 E31F Temperature Probe](#)
 - [3.4 NE117 Temperature Probe \(Model: LHT65N-NE117\)](#)
 - [3.5 Dry Contact Probe \(Model: LHT65N-DC\)](#)
 - [3.6 Door Sensor \(Model: LHT65N-DS\)](#)
 - [3.6 NIS Certificate Probe \(Model: LHT65N-NIS\)](#)
- [4. Configure LHT65N via AT command or LoRaWAN downlink](#)
 - [4.1 Set Transmit Interval Time](#)
 - [4.2 Set External Sensor Mode](#)
 - [4.3 Enable/Disable uplink DS18B20 Temperature probe ID](#)
 - [4.4 Set Password](#)
 - [4.5 Quit AT Command](#)
 - [4.6 Set to sleep mode](#)
 - [4.7 Set system time](#)
 - [4.8 Set Time Sync Mode](#)
 - [4.9 Set Time Sync Interval](#)
 - [4.10 Get data](#)
 - [4.11 Print data entries base on page](#)
 - [4.12 Print last few data entries](#)
 - [4.13 Clear Flash Record](#)
 - [4.14 Auto Send None-ACK messages](#)
 - [4.15 Modified WMOD command for external sensor TMP117 or DS18B20 temperature alarm\(Since firmware 1.3.0\)](#)
 - [4.16 Get Firmware Version Info\(Since V1.4.0\)](#)

- [4.17 Setting LEDAlarm](#)
- [5. Battery & How to replace](#)
 - [5.1 Battery Type](#)
 - [5.2 Replace Battery](#)
 - [5.3 Battery Life Analyze](#)
- [6. FAQ](#)
 - [6.1 How to connect to LHT65N UART interface?](#)
 - [6.2 How to use AT Commands?](#)
 - [6.3 How to use Downlink commands?](#)
 - [6.4 How to change the uplink interval?](#)
 - [6.5 How to upgrade firmware?](#)
 - [6.5.1 Burning firmware before V1.3 \(including V1.3\)](#)
 - [6.5.2 Updated firmware for V1.4 and above](#)
 - [6.5.2.1 Update firmware \(Assume device already have bootloader\)](#)
 - [6.5.2.2 Update firmware \(Assume device doesn't have bootloader\)](#)
 - [6.6 Why can't I see the datalog information](#)
 - [6.7 How can i read sensor data without LoRaWAN? For Calibration Purpose](#)
- [7. Order Info](#)
- [8. Packing Info](#)
- [9. Reference material](#)
- [10. FCC Warning](#)

1. Introduction

1.1 What is LHT65N LoRaWAN Temperature & Humidity Sensor

The Dragino **LHT65N Temperature & Humidity sensor** is a Long Range LoRaWAN Sensor. It includes a **built-in Temperature & Humidity sensor** and has an external sensor connector to connect to an external **Temperature Sensor**.

The LHT65N allows users to send data and reach extremely long ranges. It provides ultra-long range spread spectrum communication and high interference immunity whilst minimizing current consumption. It targets professional wireless sensor network applications such as irrigation systems, smart metering, smart cities, building automation, and so on.

LHT65N has a **built-in 2400mAh non-chargeable battery** which can be used for up to 10 years*.

LHT65N is full compatible with LoRaWAN v1.0.3 Class A protocol, it can work with a standard LoRaWAN gateway.

LHT65N supports **Datalog Feature**. It will record the data when there is no network coverage and users can retrieve the sensor value later to ensure no miss for every sensor reading.

*The actual battery life depends on how often to send data, please see the battery analyzer chapter.

1.2 Features

- LoRaWAN v1.0.3 Class A protocol
- Frequency Bands: CN470/EU433/KR920/US915/EU868/AS923/AU915
- AT Commands to change parameters
- Remote configure parameters via LoRaWAN Downlink
- Firmware upgradeable via program port
- Built-in 2400mAh battery for up to 10 years of use.
- Built-in Temperature & Humidity sensor
- Optional External Sensors
- Tri-color LED to indicate working status
- Datalog feature (Max 3328 records)

1.3 Specification

Built-in Temperature Sensor:

- Resolution: 0.01 °C
- Accuracy Tolerance : Typ ± 0.3 °C
- Long Term Drift: < 0.02 °C/yr
- Operating Range: -40 ~ 85 °C

Built-in Humidity Sensor:

- Resolution: 0.04 %RH
- Accuracy Tolerance : Typ ± 3 %RH
- Long Term Drift: < 0.25 RH/yr
- Operating Range: 0 ~ 96 %RH

External Temperature Sensor:

- Resolution: 0.0625 °C
- ± 0.5 °C accuracy from -10 °C to +85 °C
- ± 2 °C accuracy from -55 °C to +125 °C
- Operating Range: -55 °C ~ 125 °C

2. Connect LHT65N to IoT Server

2.1 How does LHT65N work?

LHT65N is configured as LoRaWAN OTAA Class A mode by default. Each LHT65N is shipped with a worldwide unique set of OTAA keys. To use LHT65N in a LoRaWAN network, first, we need to put the OTAA keys in LoRaWAN Network Server and then activate LHT65N.

If LHT65N is under the coverage of this LoRaWAN network. LHT65N can join the LoRaWAN network automatically. After successfully joining, LHT65N will start to measure environment temperature and humidity, and start to transmit sensor data to the LoRaWAN server. The default period for each uplink is 20 minutes.

2.2 How to Activate LHT65N?

The LHT65N has two working modes:

- **Deep Sleep Mode:** LHT65N doesn't have any LoRaWAN activation. This mode is used for storage and shipping to save battery life.
- **Working Mode:** In this mode, LHT65N works as LoRaWAN Sensor mode to Join LoRaWAN network and send out the sensor data to the server. Between each sampling/tx/rx periodically, LHT65N will be in STOP mode (IDLE mode), in STOP mode, LHT65N has the same power consumption as Deep Sleep mode.

The LHT65N is set in deep sleep mode by default; The ACT button on the front is to switch to different modes:



Behavior on ACT	Function	Action
Pressing ACT between 1s < time < 3s	Test uplink status	If LHT65N is already Joined to the LoRaWAN network, LHT65N will send an uplink packet, if LHT65N has external sensor connected, Blue led will blink once. If LHT65N has not external sensor, Red led will blink once.
Pressing ACT for more than 3s	Active Device	Green led will fast blink 5 times, LHT65N will enter working mode and start to JOIN LoRaWAN network. Green led will solidly turn on for 5 seconds after join in network.
Fast press ACT 5 times.	Deactivate Device	Red led will solid on for 5 seconds. Means LHT65N is in Deep Sleep Mode.

2.3 Example to join LoRaWAN network

This section shows an example of how to join the TTN V3 LoRaWAN IoT server. Use with other LoRaWAN IoT servers is of a similar procedure.

LHT65N in a LoRaWAN Network

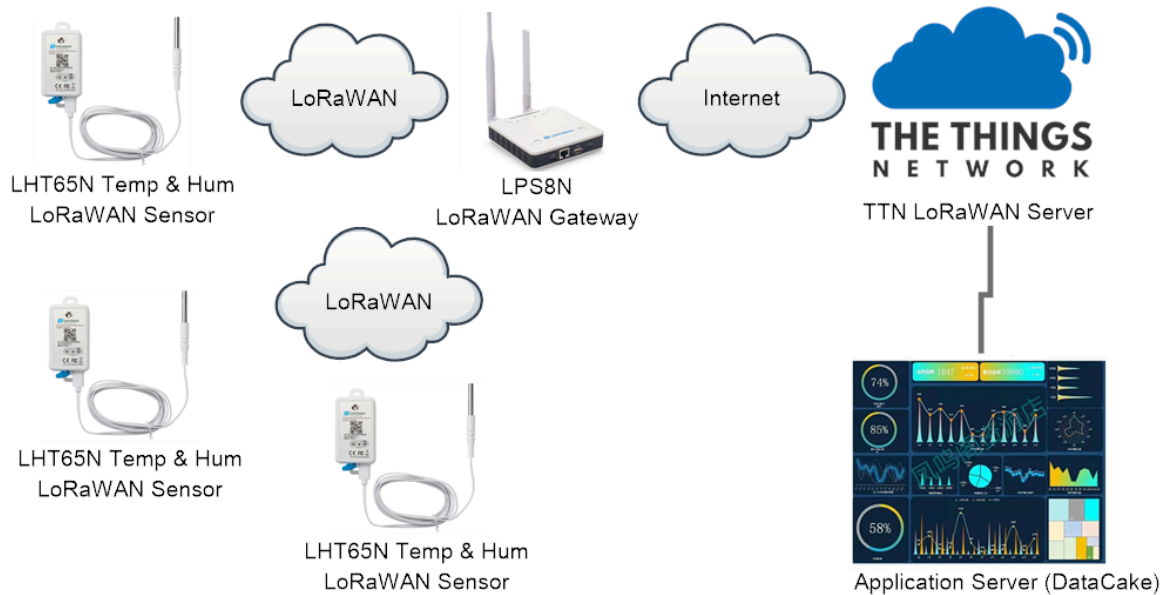

Assume the LPS8N is already set to connect to [TTN V3 network](#), So it provides network coverage for LHT65N. Next we need to add the LHT65N device in TTN V3:

2.3.1 Step 1: Create Device on TTN

Create a device in TTN V3 with the OTAA keys from LHT65N.

Each LHT65N is shipped with a sticker with its device EUJ, APP Key and APP EUJ as below:

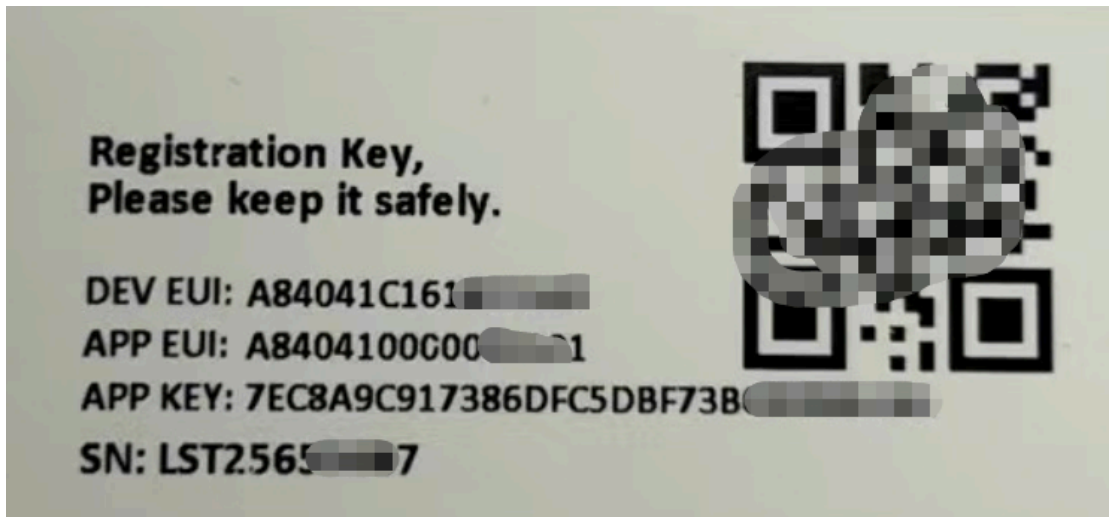

User can enter these keys in the LoRaWAN Server portal. Below is TTN V3 screenshot:

1. Create application

2. Add devices to the created Application.

3. Enter end device specifics manually.

2.3.2 Step 2: Add decoder

In TTN, user can add a custom payload so it shows friendly reading.

Click this link to get the decoder: [LHT65N decoder](#).

Below is TTN screen shot

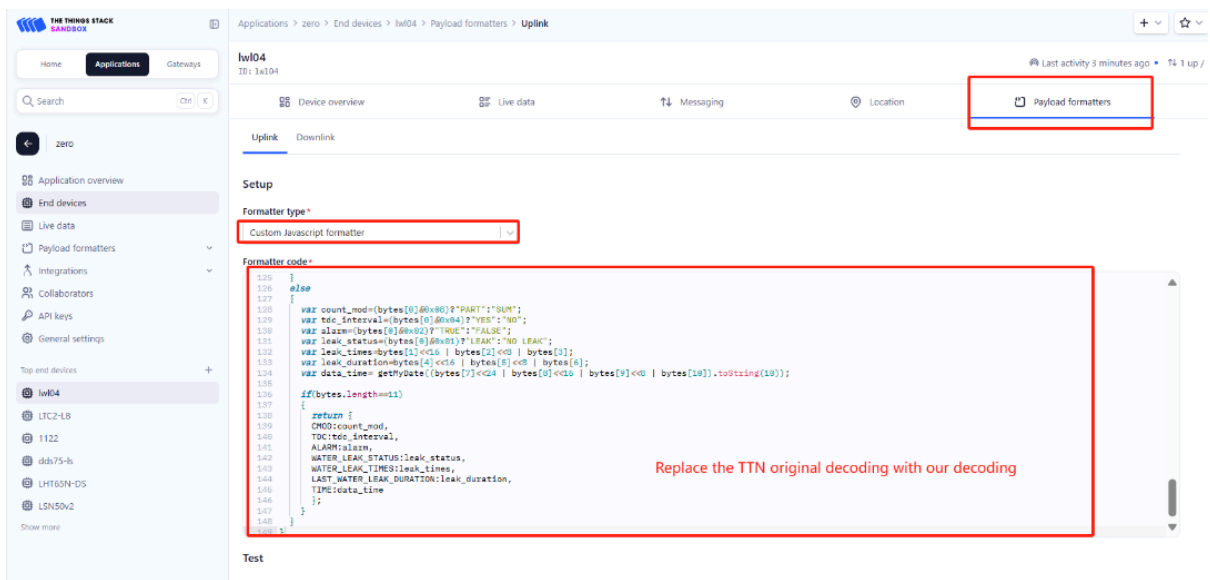

User Manual for LoRaWAN /NB -IoT End Nodes - LHT65N

LoRaWAN Temperature & Humidity Sensor Manual

Byte payload: 04 00 00 00 00 00 00 66 DE AF E6

FPort: 2

Decoded test payload:

```
{
  "ALARM": "FALSE",
  "CMD0": "SUM",
  "LAST_WATER_LEAK_DURATION": 0,
  "TDC": "YES",
  "TIME": "2024-09-09 08:28:54",
  "WATER_LEAK_STATUS": "NO LEAK",
  "WATER_LEAK_TIMES": 0
}
```

Complete uplink data:

```
{
  "f_port": 2,
  "frm_payload": "BAAAAAAAAAGbe+Y=",
  "decoded_payload": {
    "ALARM": "FALSE",
    "CMD0": "SUM",
    "LAST_WATER_LEAK_DURATION": 0,
    "TDC": "YES",
    "TIME": "2024-09-09 08:28:54",
    "WATER_LEAK_STATUS": "NO LEAK",
    "WATER_LEAK_TIMES": 0
  }
}
```

Save changes

2.3.3 Step 3: Activate LHT65N by pressing the ACT button for more than 5 seconds.

Use ACT button to activate LHT65N and it will auto-join to the TTN V3 network. After join success, it will start to upload sensor data to TTN V3 and user can see in the panel.

Time: 10:09:42

Type: Forward uplink data message

Data preview: C8 F4 0B D4 02 31 01 7F FF 7F FF

2.4 Uplink Payload (Fport=2)

The uplink payload includes totally 11 bytes. Uplink packets use FPORT=2 and every 20 minutes send one uplink by default.

After each uplink, the BLUE LED will blink once.

Size(bytes)	2	2	2	1	4
Value	BAT	Built-In Temperature	Built-in Humidity	Ext #	Ext value

- The First 6 bytes: has fix meanings for every LHT65N.
- The 7th byte (EXT #): defines the external sensor model.
- The 8th ~ 11th byte: the value for external sensor value. The definition is based on external sensor type. (If EXT=0, there won't be these four bytes.)

2.4.1 Decoder in TTN V3

User Manual for LoRaWAN /NB -IoT End Nodes - LHT65N LoRaWAN Temperature & Humidity Sensor Manual

When the uplink payload arrives TTNv3, it shows HEX format and not friendly to read. We can add LHT65N decoder in TTNv3 for friendly reading.

Below is the position to put the decoder and LHT65N decoder can be download from here: <https://github.com/dragino/dragino-end-node-decoder>

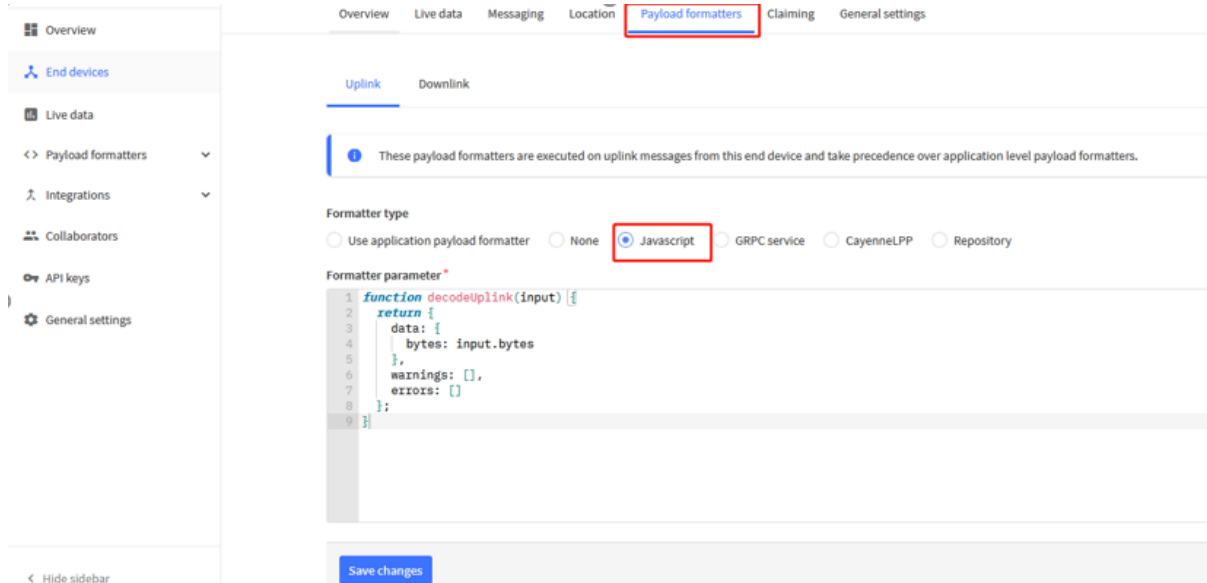

2.4.2 BAT-Battery Info

These two bytes of BAT include the battery state and the actually voltage.

Bit(bit)	[15:14]	[13:0]
Value	BAT Status 00(b): Ultra Low (BAT <= 2.50v) 01(b): Low (2.50v <=BAT <= 2.55v) 10(b): OK (2.55v <= BAT <=2.65v) 11(b): Good (BAT >= 2.65v)	Actually BAT voltage

(b)stands for binary

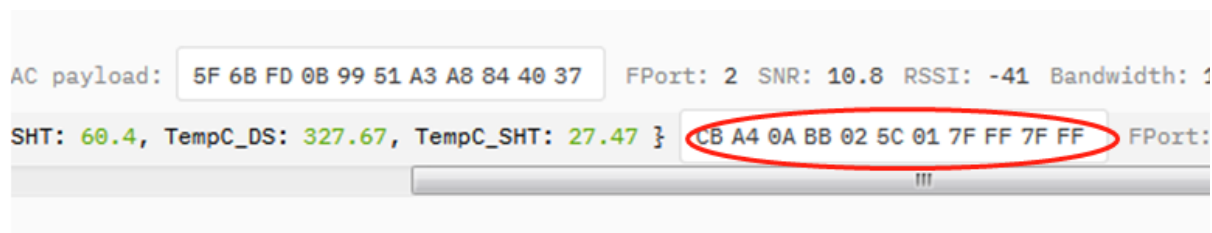

Check the battery voltage for LHT65N.

- BAT status=(0xcba4>>14)&0xFF=11 (BIN) , very good

- Battery Voltage =0xCBA4&0x3FFF=0x0BA4=2980mV

2.4.3 Built-in Temperature

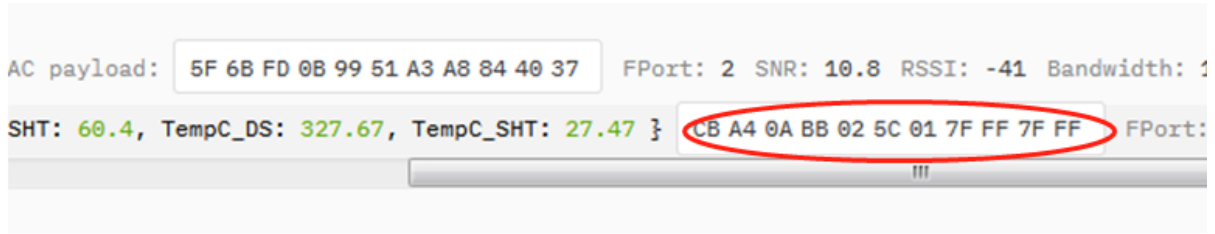

- Temperature: 0x0ABB/100=27.47°C

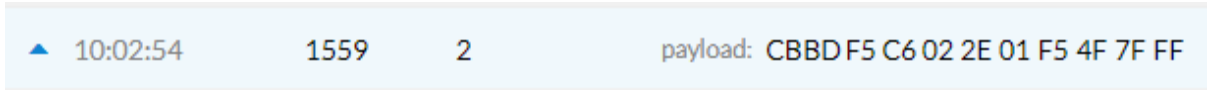

- Temperature: (0xF5C6-65536)/100=-26.18°C

2.4.4 Built-in Humidity

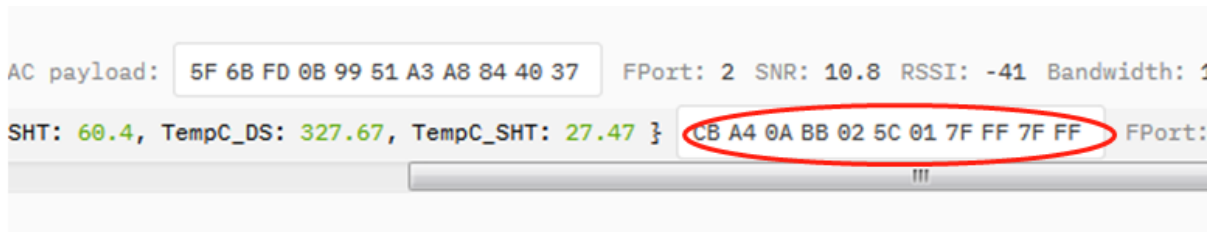

- Humidity: 0x025C/10=60.4%

2.4.5 Ext

Bytes for External Sensor:

EXT # Value	External Sensor Type
0x01	Sensor E3, Temperature Sensor
0x09	Sensor E3, Temperature Sensor, Datalog Mod
0x06	ADC Sensor(use with E2 Cable)
0x02	TMP117 Sensor
0x11	SHT31 Sensor
0x04	Interrupt Mode
0x08	Counting Mode
0x10	E2 sensor (TMP117)with Unix Timestamp

2.4.6 Ext value

2.4.6.1 Ext=1, E3 Temperature Sensor

Size(bytes)	2	2	2	1	2	2
Value	BAT & BAT Status	TempC_SHT	Hum_SHT	Status & Ext	TempC_DS	senseless

APPLICATION DATA

Filters				
uplink	downlink	activation	ack	error
time	counter	port		
▲ 08:38:57	375	2	payload: CB F6 0B 0D 03 76 01 0A DD 7F FF	

- DS18B20 temp=0x0ADD/100=27.81°C

The last 2 bytes of data are meaningless

▲ 10:02:54	1559	2	payload: CBBDF5 C6 02 2E 01 F5 4F 7F FF
------------	------	---	---

- External temperature= (0xF54F-65536)/100=-27.37°C

F54F: (F54F & 8000 == 1) , temp = (F54F - 65536)/100 = 27.37°C

(0105 & 8000: Judge whether the highest bit is 1, when the highest bit is 1, it is *negative*)

The last 2 bytes of data are meaningless

If the external sensor is 0x01, and there is no external temperature connected. The temperature will be set to 7FFF which is 327.67°C

2.4.6.2 Ext=9, E3 sensor with Unix Timestamp

Timestamp mode is designed for LHT65N with E3 probe, it will send the uplink payload with Unix timestamp. With the limitation of 11 bytes (max distance of AU915/US915/AS923 band), the time stamp mode will be lack of BAT voltage field, instead, it shows the battery status. The payload is as below:

Size(bytes)	2	2	2	1	4
Value	External temperature	Built-In Temperature	BAT Status & Built-in Humidity	Status & Ext	Unix Time Stamp

- **Battery status & Built-in Humidity**

Bit(bit)	[15:14]	[11:0]
Value	BAT Status 00(b): Ultra Low (BAT <= 2.50v) 01(b): Low (2.50v <=BAT <= 2.55v) 10(b): OK (2.55v <= BAT <=2.65v) 11(b): Good (BAT >= 2.65v)	Built-in Humidity

- **Status & Ext Byte**

Bits	7	6	5	4	[3:0]
Status&Ext	None-ACK Flag	Poll Message FLAG	Sync time OK	Unix Time Request	Ext: 0b(1001)

- **Poll Message Flag:** 1: This message is a poll message reply, 0: means this is a normal uplink.
- **Sync time OK:** 1: Set time_{ok}, 0: N/A. After time SYNC request is sent, LHT65N will set this bit to 0 until got the time stamp from the application server.

- **Unix Time Request:** 1: Request server downlink Unix time, 0 : N/A. In this mode, LHT65N will set this bit to 1 every 10 days to request a time SYNC. (AT+SYNCMOD to set this)

2.4.6.3 Ext=6, ADC Sensor(use with E2 Cable)

Size(bytes)	2	2	2	1	2	2
Value	BAT & BAT Status	TempC_SHT	Hum_SHT	Status & Ext	ADC_Value	senseless

In this mode, user can connect external ADC sensor to check ADC value. The 3V3_OUT can be used to power the external ADC sensor; user can control the power on time for this

sensor by setting:

AT+EXT=6,timeout **Time to power this sensor, from 0 ~ 65535ms**

For example:

AT+EXT=6,1000 will power this sensor for 1000ms before sampling the ADC value.

Or use **downlink command A2** to set the same.

The measuring range of the node is only about 0.1V to 1.1V The voltage resolution is about 0.24mv.

When the measured output voltage of the sensor is not within the range of 0.1V and 1.1V, the output voltage terminal of the sensor shall be divided The example in the following figure is to reduce the output voltage of the sensor by three times If it is necessary to reduce more times, calculate according to the formula in the figure and connect the corresponding resistance in series.

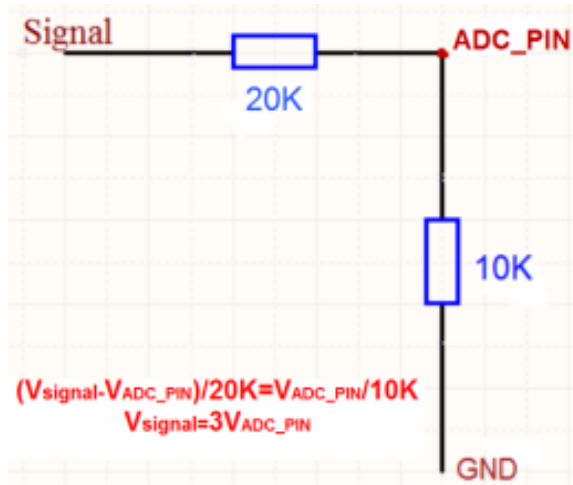

When ADC_IN1 pin is connected to GND or suspended, ADC value is 0

```

Payload: { ADC_V: 0, BatV: 3.106, Bat_status: 3, Hum_SHT: 45.2, TempC_SHT: 28.11, Work_mode: "ADC Sensor" }
    
```

When the voltage collected by ADC_IN1 is less than the minimum range, the minimum range will be used as the output; Similarly, when the collected voltage is greater than the maximum range, the maximum range will be used as the output.

1) The minimum range is about 0.1V. Each chip has internal calibration, so this value is close to 0.1V

```

Payload: { ADC_V: 0.084, BatV: 3.106, Bat_status: 3, Hum_SHT: 44.9, TempC_SHT: 28.13, Work_mode: "ADC Sensor" }
    
```

2) The maximum range is about 1.1V. Each chip has internal calibration, so this value is close to 1.1v

User Manual for LoRaWAN /NB -IoT End Nodes - LHT65N
LoRaWAN Temperature & Humidity Sensor Manual

```
Payload: { ADC_V: 1.085, BatV: 3.108, Bat_status: 3, Hum_SHT: 46.5, TempC_SHT: 28.16, Work_mode: "ADC Sensor" }
```

3) Within range

```
Payload: { ADC_V: 0.427, BatV: 3.099, Bat_status: 3, Hum_SHT: 45.1, TempC_SHT: 27.47, Work_mode: "ADC Sensor" }
```

2.4.6.4 Ext=2 TMP117 Sensor(Since Firmware v1.3)



Ext=2, Temperature Sensor(TMP117):

Size(bytes)	2	2	2	1	2	2
Value	BAT & BAT Status	TempC_SHT	Hum_SHT	Status & Ext	TempC_Temp117	senseless

```
Payload: { BatV: 3.054, Bat_status: 3, Ext_sensor: "Temperature Sensor", Hum_SHT: 59.9, TempC_SHT: 29.16, TempC_TMP117: 27.55 }
```

Interrupt Mode and Counting Mode:

The external cable NE2 can be use for MOD4 and MOD8

2.4.6.5 Ext=11 SHT31 Sensor (Since Firmware v1.4.1)



Ext=11, Temperature & Humidity Sensor(SHT31):

Size(bytes)	2	2	2	1	2	2
Value	BAT & BAT Status	TempC_SHT	Hum_SHT	Status & Ext	Ext_TempC_SHT	Ext_Hum_SHT

```
Payload: { BatV: 3.072, Bat_status: 3, Ext_Hum_SHT: 61.9, Ext_TempC_SHT: 27.58, Hum_SHT: 61.9, TempC_SHT: 28.26, Work_mode: "SHT31 Sensor" } CC 00 0B 0A 02 6B 0B 0A ...
```

2.4.6.6 Ext=4 Interrupt Mode(Since Firmware v1.3)

Note: In this mode, 3.3v output will be always ON. LHT65N will send an uplink when there is a trigger.

Interrupt Mode can be used to connect to external interrupt sensors such as:

Case 1: Door Sensor. 3.3v Out for such sensor is just to detect Open/Close.

In Open State, the power consumption is the same as if there is no probe

In Close state, the power consumption will be 3uA higher than normal.

User Manual for LoRaWAN /NB -IoT End Nodes - LHT65N
LoRaWAN Temperature & Humidity Sensor Manual

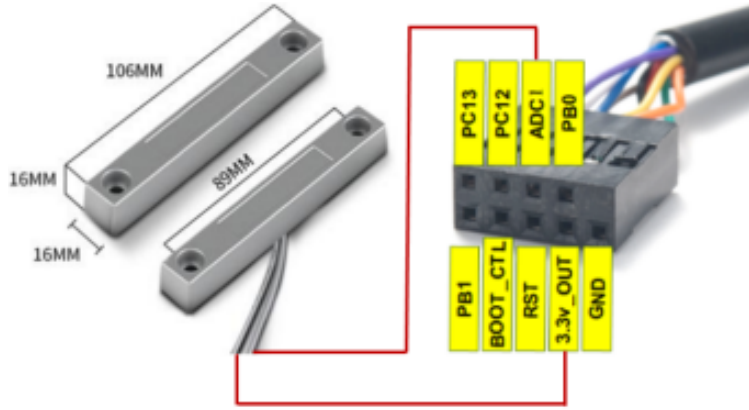

Ext=4, Interrupt Sensor:

AT+EXT=4,1	Sent uplink packet in both rising and falling interrupt						
AT+EXT=4,2	Sent uplink packet only in falling interrupt						
AT+EXT=4,3	Sent uplink packet only in rising interrupt						
Size(bytes)	2	2	2	1	1	1	2
Value	BAT & BAT Status	TempC_SHT	Hum_SHT	Status & Ext	Exti_pin_level	Exti_status	senseless

Trigger by falling edge:

```
Payload: { BatV: 3.078, Bat_status: 3, Exti_pin_level: "Low", Exti_status: "True", Hum_SHT: 48.4, TempC_SHT: 28.3, Work_mode: "Interrupt Sensor send" }
```

Trigger by raising edge:

```
Payload: { BatV: 3.079, Bat_status: 3, Exti_pin_level: "High", Exti_status: "True", Hum_SHT: 48.6, TempC_SHT: 28.3, Work_mode: "Interrupt Sensor send" }
```

BAT & BAT Status :

Check the battery voltage.

Ex1: 0x0B45 = 2885mV

Ex2: 0x0B49 = 2889mV

TempC_SHT :

The temperature detected by the built-in temperature and humidity sensor SHT31.

If payload is: 0105H: (0105 & 8000 == 0), temp = 0105H / 10 = 26.1 degree

If payload is: FF3FH : (FF3F & 8000 == 1) , temp = (FF3FH - 65536)/10 = -19.3 degrees.

(FF3F & 8000: Judge whether the highest bit is 1, when the highest bit is 1, it is negative)

Hum_SHT :

The humidity detected by the built-in temperature and humidity sensor SHT31.

Read:0295(H)=661(D) Value: 661 / 10=66.1, So 66.1%

Status & Ext :

Bits	7	6	5	4	[3:0]
-------------	----------	----------	----------	----------	--------------

User Manual for LoRaWAN /NB -IoT End Nodes - LHT65N
LoRaWAN Temperature & Humidity Sensor Manual

Status&Ext	None-ACK Flag	Poll Message FLAG	Sync time OK	Unix Time Request	Ext: 0b(1001)
------------	---------------	-------------------	--------------	-------------------	---------------

- **Poll Message Flag:** 1: This message is a poll message reply, 0: means this is a normal uplink.
- **Sync time OK:** 1: Set time_{ok}, 0: N/A. After time SYNC request is sent, LHT65N will set this bit to 0 until got the time stamp from the application server.
- **Unix Time Request:** 1: Request server downlink Unix time, 0 : N/A. In this mode, LHT65N will set this bit to 1 every 10 days to request a time SYNC. (AT+SYNCMOD to set this)

Exti_pin_level :

- **Wet contacts:** high and low levels . 1: high level; 0: low level.
- **Dry contacts:** 1: closed; 0: open

Exti_status :

Determines whether the uplink packet is generated by an interrupt.

1: Interrupt packet

0: Normal TDC uplink packet

senseless :

Reserved position, meaningless. The value is fixed to 0x7FFF.

2.4.6.7 Ext=8 Counting Mode(Since Firmware v1.3)

Note: In this mode, 3.3v output will be always ON. LHT65N will count for every interrupt and uplink periodically.

Case 1: Low power consumption Flow Sensor, such flow sensor has pulse output and the power consumption in uA level and can be powered by LHT65N.

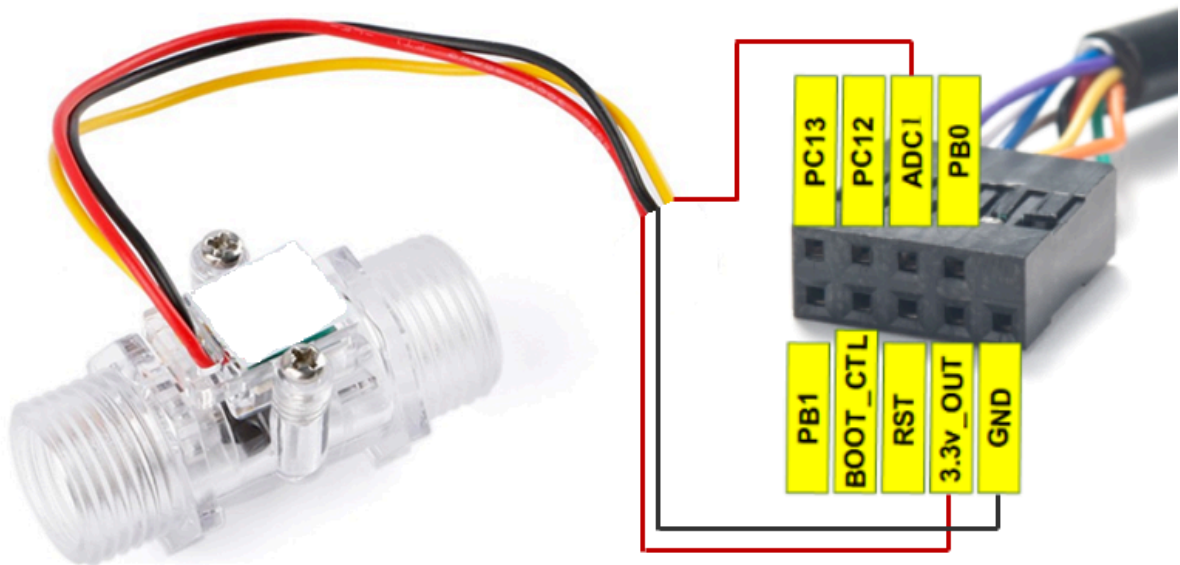

Case 2: Normal Flow Sensor: Such flow sensor has higher power consumption and is not suitable to be powered by LHT65N. It is powered by external power and output <3.3v pulse

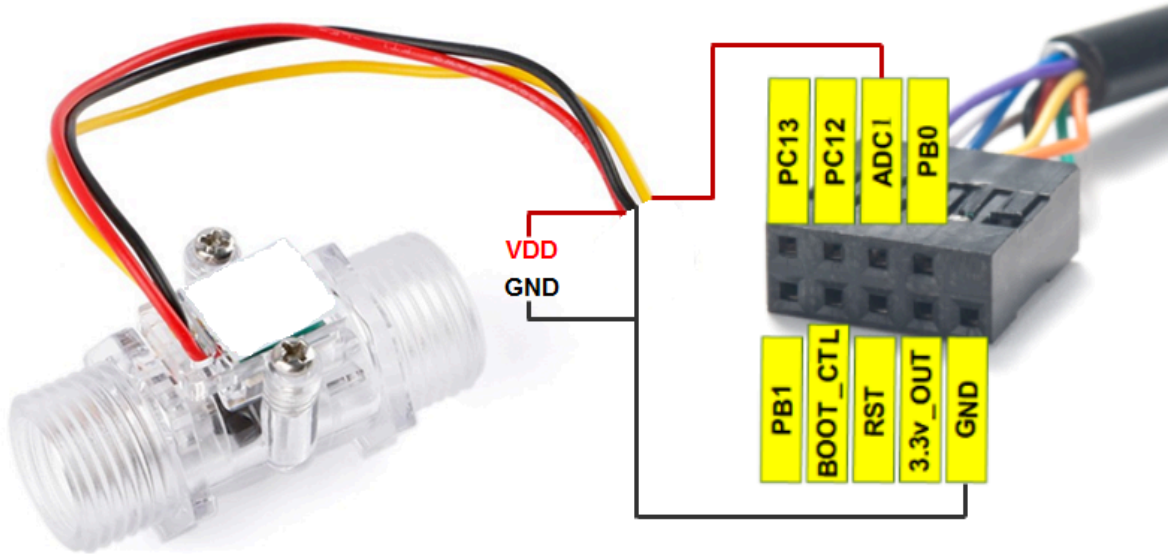

Ext=8, Counting Sensor (4 bytes):

AT+EXT=8,0	Count at falling interrupt				
AT+EXT=8,1	Count at rising interrupt				
AT+SETCNT=60	Sent current count to 60				
Size(bytes)	2	2	2	1	4
Value	BAT & BAT Status	TempC_SHT	Hum_SHT	Status & Ext	Exit_count

Payload: { BatV: 3.072, Bat_status: 3, Exit_count: 25, Hum_SHT: 48.6, TempC_SHT: 28.41, Work_mode: "Interrupt Sensor count" }

A2 downlink Command:

A2 02: Same as AT+EXT=2 (AT+EXT= second byte)

A2 06 01 F4: Same as AT+EXT=6,500 (AT+EXT= second byte, third and fourth bytes)

A2 04 02: Same as AT+EXT=4,2 (AT+EXT= second byte, third byte)

A2 08 01 00: Same as AT+EXT=8,0 (AT+EXT= second byte, fourth byte)

A2 08 02 00 00 00 3C: Same as AT+ SETCNT=60 (AT+ SETCNT = 4th byte and 5th byte and 6th byte and 7th byte)

2.4.6.8 Ext=10, E2 sensor (TMP117)with Unix Timestamp(Since firmware V1.3.2)

Timestamp mode is designed for LHT65N with E2 probe, it will send the uplink payload with Unix timestamp. With the limitation of 11 bytes (max distance of AU915/US915/AS923 band), the time stamp mode will be lack of BAT voltage field, instead, it shows the battery status. The payload is as below:

User Manual for LoRaWAN /NB -IoT End Nodes - LHT65N
LoRaWAN Temperature & Humidity Sensor Manual

Size(bytes)	2	2	2	1	4
Value	External temperature	Built-In Temperature	BAT Status & Built-in Humidity	Status & Ext	Unix Time Stamp

• **Battery status & Built-in Humidity**

Bit(bit)	[15:14]	[11:0]
Value	BAT Status 00(b): Ultra Low (BAT <= 2.50v) 01(b): Low (2.50v <=BAT <= 2.55v) 10(b): OK (2.55v <= BAT <=2.65v) 11(b): Good (BAT >= 2.65v)	Built-in Humidity

• **Status & Ext Byte**

Bits	7	6	5	4	[3:0]
Status&Ext	None-ACK Flag	Poll Message FLAG	Sync time OK	Unix Time Request	Ext: 0b(1001)

- **Poll Message Flag:** 1: This message is a poll message reply, 0: means this is a normal uplink.
- **Sync time OK:** 1: Set time ok, 0: N/A. After time SYNC request is sent, LHT65N will set this bit to 0 until got the time stamp from the application server.
- **Unix Time Request:** 1: Request server downlink Unix time, 0 : N/A. In this mode, LHT65N will set this bit to 1 every 10 days to request a time SYNC. (AT+SYNCMOD to set this)

2.5 Show data on Datacake

Datacake IoT platform provides a human-friendly interface to show the sensor data, once we have sensor data in TTN V3, we can use Datacake to connect to TTN V3 and see the data in Datacake. Below are the steps:

Step 1: Be sure that your device is programmed and properly connected to the LoRaWAN network.

Step 2: Configure your Application to forward data to Datacake you will need to add integration. Go to TTN V3 Console --> Applications --> Integrations --> Add Integrations.

Add Datacake:

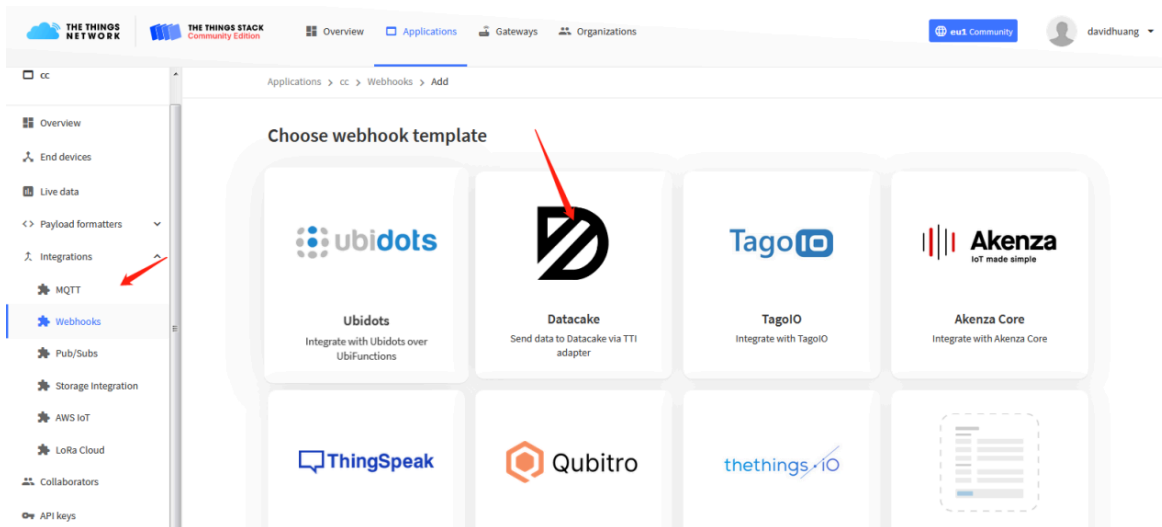

Select default key as Access Key:

Applications > lgt92test > Webhooks > Add > Datacake

Add custom webhook

Template information



Datacake

Send data to Datacake via TTI adapter

[About Datacake](#) | [Documentation](#)

Template settings

Webhook ID *

Token *

Datacake API Token

Create datacake webhook

In Datacake console (<https://datacake.co/>) , add LHT65 device.

User Manual for LoRaWAN /NB -IoT End Nodes - LHT65N

LoRaWAN Temperature & Humidity Sensor Manual

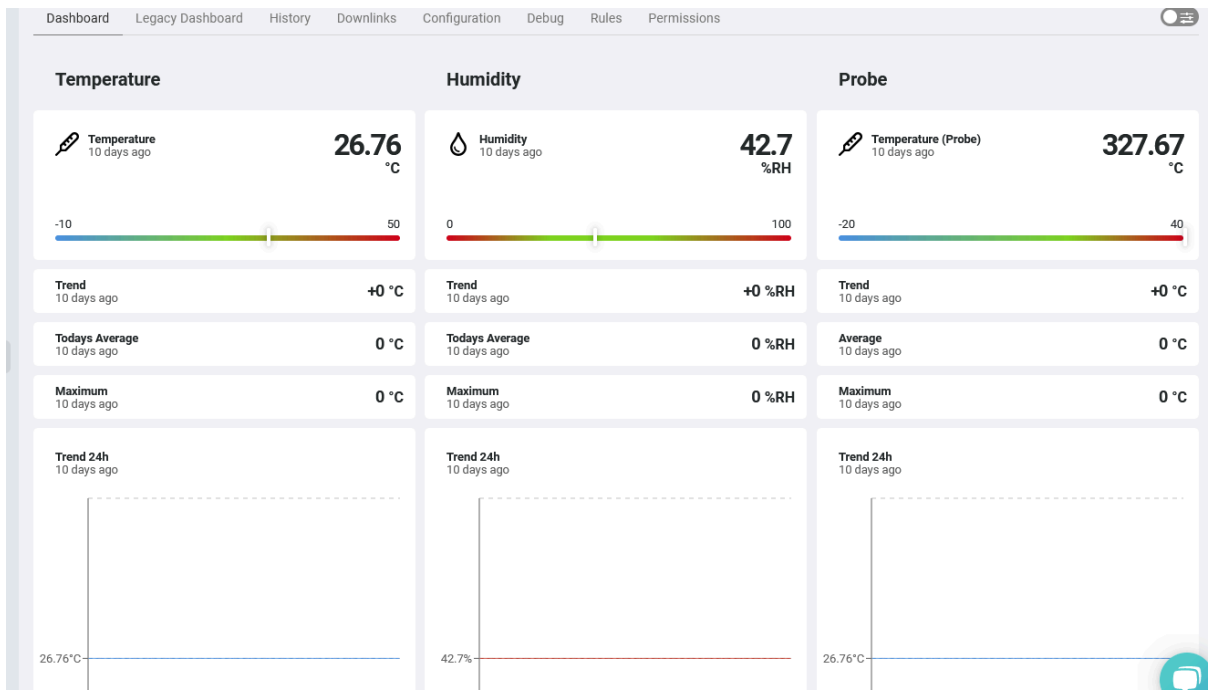
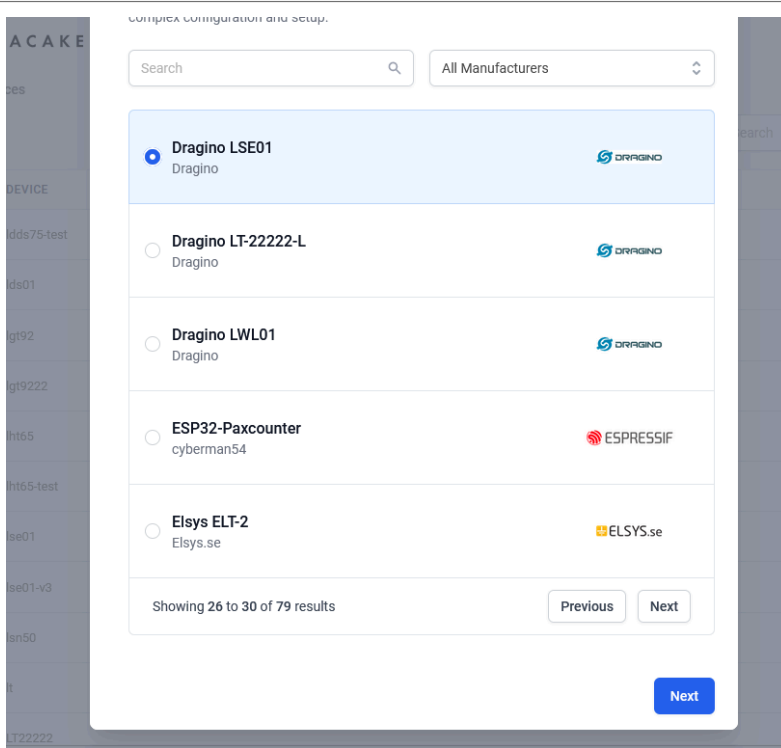

2.6 Datalog Feature

Datalog Feature is to ensure IoT Server can get all sampling data from Sensor even if the LoRaWAN network is down. For each sampling, LHT65N will store the reading for future retrieving purposes. There are two ways for IoT servers to get datalog from LHT65N.

2.6.1 Ways to get datalog via LoRaWAN

There are two methods:

Method 1: IoT Server sends a downlink LoRaWAN command to [poll the value](#) for specified time range.

Method 2: Set `PNACKMD=1`, LHT65N will wait for ACK for every uplink, when there is no LoRaWAN network, LHT65N will mark these records with non-ack messages and store the sensor data, and it will send all messages (10s interval) after the network recovery.

Note for method 2:

- a) LHT65N will do an ACK check for data records sending to make sure every data arrive server.
- b) LHT65N will send data in **CONFIRMED Mode** when `PNACKMD=1`, but LHT65N won't re-transmit the packet if it doesn't get ACK, it will just mark it as a NONE-ACK message. In a future uplink if LHT65N gets a ACK, LHT65N will consider there is a network connection and resend all NONE-ACK Message.

Below is the typical case for the auto-update datalog feature (Set `PNACKMD=1`)

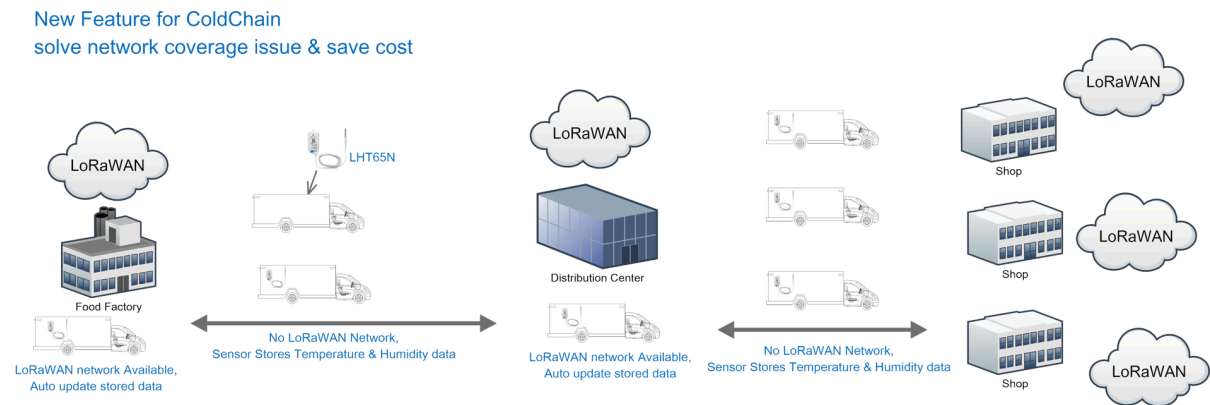

2.6.2 Unix TimeStamp

LHT65N uses Unix TimeStamp format based on

Size (bytes)	4	1
DeviceTimeAns Payload	32-bit unsigned integer : Seconds since epoch*	8bits unsigned integer: fractional-second in $\frac{1}{2}^8$ second steps

Figure 10 : DeviceTimeAns payload format

User can get this time from link: <https://www.epochconverter.com/> :

Below is the converter example

The screenshot shows two web interfaces. On the left, EpochConverter displays 'The current Unix epoch time is 1611889418'. Below it, a conversion tool shows '1611889090' converted to a human-readable date: '2021年1月29日 Friday 02:58:10'. On the right, Code Beautify's 'Decimal to Hex' converter shows the decimal number '1611889405' being converted to the hexadecimal value '60137afd'. A red arrow points from the epoch time '1611889418' to the decimal input '1611889405'.

So, we can use AT+TIMESTAMP=1611889405 or downlink 3060137afd00 to set the current time 2021 – Jan -- 29 Friday 03:03:25

2.6.3 Set Device Time

There are two ways to set device's time:

1. Through LoRaWAN MAC Command (Default settings)

User need to set SYNCMOD=1 to enable sync time via MAC command.

Once LHT65N Joined LoRaWAN network, it will send the MAC command (DeviceTimeReq) and the server will reply with (DeviceTimeAns) to send the current time to LHT65N. If LHT65N fails to get the time from the server, LHT65N will use the internal time and wait for next time request (AT+SYNCTDC to set the time request period, default is 10 days).

Note: LoRaWAN Server need to support LoRaWAN v1.0.3(MAC v1.0.3) or higher to support this MAC command feature, Chirpstack,TTN V3 v3 and loriot support but TTN V3 v2 doesn't support. If server doesn't support this command, it will through away uplink packet with this command, so user will lose the packet with time request for TTN V3 v2 if SYNCMOD=1.

2. Manually Set Time

User needs to set SYNCMOD=0 to manual time, otherwise, the user set time will be overwritten by the time set by the server.

2.6.4 Poll sensor value

User can poll sensor value based on timestamps from the server. Below is the downlink command.

1byte	4bytes	4bytes	1byte
31	Timestamp start	Timestamp end	Uplink Interval

Timestamp start and Timestamp end use Unix TimeStamp format as mentioned above. Devices will reply with all data log during this time period, use the uplink interval.

For example, downlink command **31 5FC5F350 5FC6 0160 05**

Is to check 2020/12/1 07:40:00 to 2020/12/1 08:40:00's data

Uplink Interval =5s, means LHT65N will send one packet every 5s. range 5~255s.

2.6.5 Datalog Uplink payload

The Datalog poll reply uplink will use below payload format.

Retrieval data payload:

Size(bytes)	2	2	2	1	4
Value	External sensor data	Built In Temperature	Built-in Humidity	Poll message flag & Ext	Unix Time Stamp

Poll message flag & Ext:

Bits	7	6	5	4	[3:0]
Status&Ext	No ACK Message	Poll Message Flag	Sync time OK	Unix Time Request	Ext: 0b(1001)

No ACK Message: 1: This message means this payload is fromn Uplink Message which doesn't get ACK from the server before (for [PNACKMD=1](#) feature)

Poll Message Flag: 1: This message is a poll message reply.

- Poll Message Flag is set to 1.
- Each data entry is 11 bytes, to save airtime and battery, devices will send max bytes according to the current DR and Frequency bands.

For example, in US915 band, the max payload for different DR is:

- DR0:** max is 11 bytes so one entry of data
- DR1:** max is 53 bytes so devices will upload 4 entries of data (total 44 bytes)
- DR2:** total payload includes 11 entries of data
- DR3:** total payload includes 22 entries of data.

If devise doesn't have any data in the polling time. Device will uplink 11 bytes of 0

Example:

If LHT65N has below data inside Flash:

Flash Add	Unix Time	Ext	BAT voltage	Value
80196E0	21/1/19 04:27:03	1	3145	sht temp=22.00 sht hum=32.6 ds temp=327.67
80196F0	21/1/19 04:28:57	1	3145	sht temp=21.90 sht hum=33.1 ds temp=327.67

User Manual for LoRaWAN /NB -IoT End Nodes - LHT65N
LoRaWAN Temperature & Humidity Sensor Manual

8019600	21/1/19 04:30:30	1	3145	sht temp=21.81 sht hum=33.4 ds temp=327.67
8019610	21/1/19 04:40:30	1	3145	sht temp=21.65 sht hum=33.7 ds temp=327.67
8019620	21/1/19 04:50:30	1	3147	sht temp=21.55 sht hum=34.1 ds temp=327.67
8019630	21/1/19 04:00:30	1	3149	sht temp=21.50 sht hum=34.1 ds temp=327.67
8019640	21/1/19 04:10:30	1	3149	sht temp=21.43 sht hum=34.6 ds temp=327.67
8019650	21/1/19 04:20:30	1	3151	sht temp=21.35 sht hum=34.9 ds temp=327.67

If user sends below downlink command: **3160065F9760066DA705**

Where : Start time: 60065F97 = time 21/1/19 04:27:03

Stop time: 60066DA7= time 21/1/19 05:27:03

LHT65N will uplink this payload.

09:57:27 102 2 payload: 7F FF 08 98 01 46 41 60 06 5F 97 7F FF 08 8E 01 4B 41 60 06 60 09 7F FF 08 85 01 4E 41 60 06 60 66 7F FF 08 75 01 51 41 60 06

Uplink

Payload

7F FF 08 98 01 46 41 60 06 5F 97 7F FF 08 8E 01 4B 41 60 06 60 09 7F FF 08 85 01 4E 41 60 06 60 66 7F FF 08 75 01 51 41 60 06

Fields

no fields

Metadata

```
{
  "time": "2021-01-20T01:57:27.690185935Z",
  "frequency": 904.5,
  "modulation": "LORA",
  "data_rate": "SF7BW125",
  "coding_rate": "4/5",
  "gateways": [
    {
      "gtw_id": "eui-a840411cfe60415c",
      "timestamp": 3270993355,
      "time": "2021-01-20T01:57:27.544057Z",
      "channel": 3,
      "rssi": -55,
      "snr": 10
    }
  ]
}
```

7FFF089801464160065F97 7FFF 088E 014B 41 60066009

7FFF0885014E41600660667FFF0875015141600662BE7FFF086B015541600665167FFF08660155416006676E7FFF085F015A41

Where the first 11 bytes is for the first entry:

7FFF089801464160065F97

Ext sensor data=0x7FFF/100=327.67

Temp=0x088E/100=22.00

Hum=0x014B/10=32.6

poll message flag & Ext=0x41, means reply data, Ext=1

Unix time is 0x60066009=1611030423s=21/1/19 04:27:03

2.7 Alarm Mode & Feature "Multi sampling, one uplink"

when the device is in alarm mode, it checks the built-in sensor temperature for a short time. if the temperature exceeds the preconfigured range, it sends an uplink immediately.

Note: alarm mode adds a little power consumption, and we recommend extending the normal read time when this feature is enabled.

2.7.1 ALARM MODE (Since v1.3.1 firmware)

AT+LEDALARM=1 : Enable LED visual Alarm. **Downlink Command: 3601**

DS18B20 and TMP117 Threshold Alarm(The mod1 use for external sensors (DS18B20 and TMP117)

AT+WMOD=1,60,-10,20

Explain:

- **parameter1:** Set Working Mode to **Mode 1**, Threshold Alarm (Out of range alarm)
- **parameter2:** Sampling Interval is **60s**.
- **parameter3 & parameter4:** Temperature alarm range is **-10 to 20°C** (Set the temperature range value with a coefficient of 100)

Downlink Command:

Example: A5013CFC1807D0

MOD=01

CITEMP=3C(S) =60(S)

TEMPlow=FC18 = -1000/100=-10(°C)

TEMPhigh=07D0=2000/100=20(°C)

Fluctuation alarm for DS18B20 and TMP117(Acquisition time: minimum 1s)(The mod2 use for external sensors (DS18B20 and TMP117)

AT+WMOD=2,60,5

Explain:

- **parameter1:** Set Working Mode to **Mode 2**, Fluctuation alarm
- **parameter2:** Sampling Interval is **60s**.
- **parameter3:** The temperature fluctuation is **+5 °C**

Downlink Command

Example: A5023C05

MOD=02

CITEMP=3C(S)=60(S)

temperature fluctuation=05(°C)

Sampling multiple times and uplink together(The mod3 can be used for internal and external sensors)
(Internal GXHT30 temperature alarm(Acquisition time: fixed at one minute))

AT+WMOD=3,1,60,20,-16,32,1

Explain:

- **parameter1:** Set Working Mode to **Mode 3**, Sampling **multiple times and uplink together**
- **parameter2:** Set the temperature sampling mode to **1**(1:DS18B20;2:TMP117;3: Internal GXHT30).
- **parameter3:** Sampling Interval is **60s**.(This parameter has no effect on internal sensors)
- **parameter4:** When there is **20** sampling data, Device will send these data via one uplink. (max value is 60, means max 60 sampling in one uplink)
- **parameter5 & parameter6:** Temperature alarm range is **-16 to 32°C**,
- **parameter7:** **1** to enable temperature alarm, **0** to disable the temperature alarm. If alarm is enabled, a data will be sent immediately if temperature exceeds the Alarm range.

Downlink Command:

Example: A50301003C14FFF0002001

MOD=03

TEMP=DS18B20

CITEMP=003C(S)=60(S)

Total number of acquisitions=14

TEMPlow=FFF0=-16(°C)

TEMPhigh=0020=20(°C)

ARTEMP=01

Uplink payload(Fport=3)

Example: CBEA0109920A4109C4

BatV=CBEA

TEMP=DS18B20

Temp1=0992 // 24.50°C

Temp2=0A41 // 26.25°C

Temp3=09C4 // 25.00°C

Note: This uplink will automatically select the appropriate DR according to the data length

In this mode, the temperature resolution of ds18b20 is 0.25°C to save power consumption

2.7.2 ALARM MODE (Before v1.3.1 firmware)

AT+WMOD=1: Enable/disable alarm mode. (0: Disabled, 1: Enabled Temperature Alarm for onboard temperature sensor)

AT+CITEMP=1: The interval between checking the alarm temperature. (In minutes)

AT+ARTEMP: Gets or sets the alarm range of the internal temperature sensor

AT+ARTEMP=? : Gets the alarm range of the internal temperature sensor

AT+ARTEMP=45,105: Set the internal temperature sensor alarm range from 45 to 105.

Downlink Command: AAXXXXXXXXXXXXXXX

Total bytes: 8 bytes

Example:AA0100010001003C

WMOD=01

CITEMP=0001

TEMPlow=0001

TEMPhigh=003C

2.8 LED Indicator

The LHT65 has a triple color LED which for easy showing different stage .

While user press ACT button, the LED will work as per LED status with ACT button.

In a normal working state:

- For each uplink, the BLUE LED or RED LED will blink once.
BLUE LED when external sensor is connected.
- RED LED when external sensor is not connected
- For each success downlink, the PURPLE LED will blink once

2.9 installation

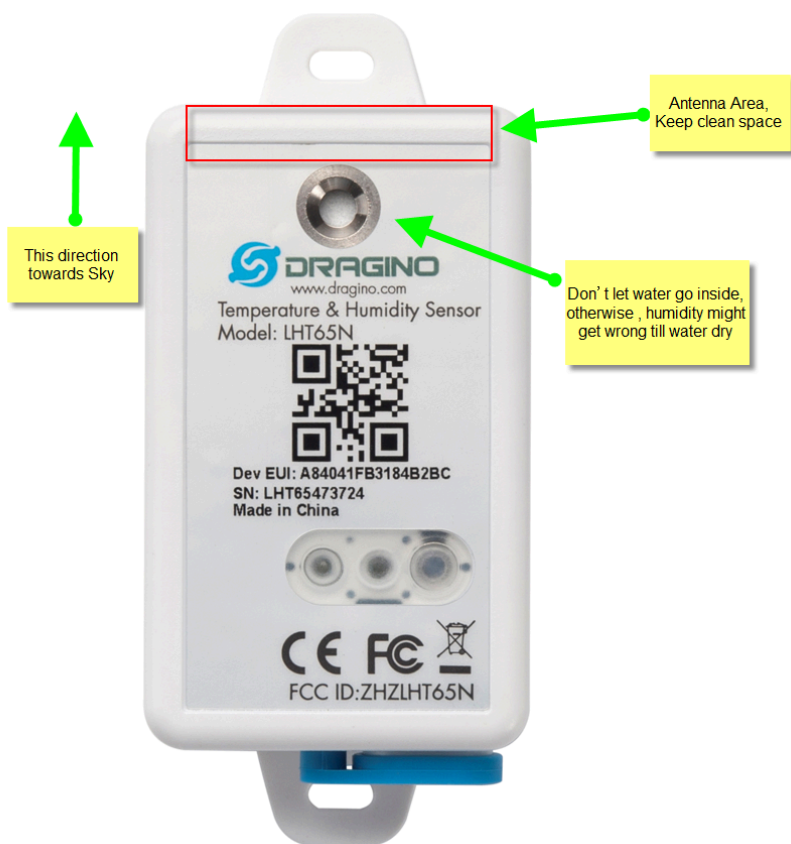

3. Sensors and Accessories

3.1 E2 Extension Cable



1m long breakout cable for LHT65N. Features:

- Use for AT Command, works for both LHT52/LHT65N
- Update firmware for LHT65N, works for both LHT52/LHT65N
- Supports ADC mode to monitor external ADC
- Supports Interrupt mode
- Exposed All pins from the LHT65N Type-C connector.

LHT65N_E2 Cable Pin Mapping

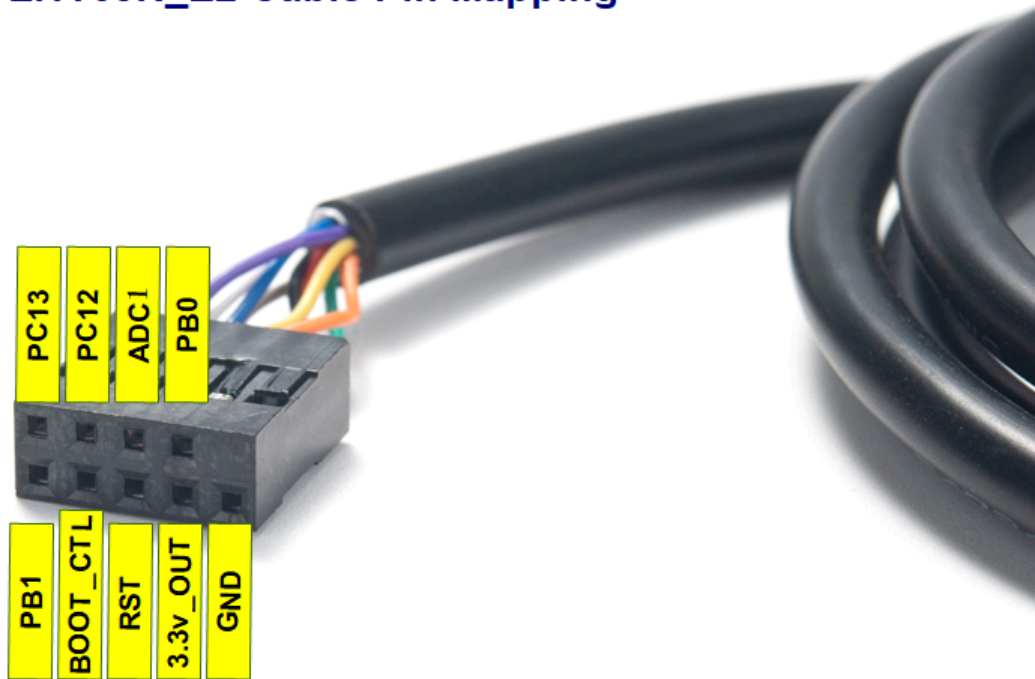

3.2 E3 Temperature Probe



Temperature sensor with 2 meters cable long

- Resolution: 0.0625 °C
- $\pm 0.5^{\circ}\text{C}$ accuracy from -10°C to $+85^{\circ}\text{C}$
- $\pm 2^{\circ}\text{C}$ accuracy from -55°C to $+125^{\circ}\text{C}$
- Operating Range: $-40 \sim 125^{\circ}\text{C}$
- Working voltage 2.35v ~ 5v

3.3 E31F Temperature Probe



Temperature sensor with 1 meters cable long

Built-in Temperature Sensor:

- Resolution: 0.01 °C
- Accuracy Tolerance : Typ $\pm 0.3^{\circ}\text{C}$
- Long Term Drift: $< 0.02^{\circ}\text{C/yr}$
- Operating Range: $-40 \sim 80^{\circ}\text{C}$

Built-in Humidity Sensor:

- Resolution: 0.04 % RH
- Accuracy Tolerance : Typ $\pm 3\%$ RH
- Long Term Drift: $< 0.25\%$ RH/yr
- Operating Range: $0 \sim 96\%$ RH

External Temperature Sensor :

- Resolution: 0.01 °C
- Accuracy Tolerance : Typical ± 0.3 °C
- Long Term Drift: < 0.02 °C/yr
- Operating Range: -40 ~ 125 °C

External Humidity Sensor :

- Resolution: 0.04 % RH
- Accuracy Tolerance : Typ ± 3 % RH
- Long Term Drift: < 0.25 RH/yr
- Operating Range: 0 ~ 96 % RH

3.4 NE117 Temperature Probe (Model: LHT65N-NE117)

External Temperature Sensor – NE117:
Equip with TMP117A temperature sensor. TMP117 IC is NIST traceability Sensor by TI.

- Silica gel cable
- ± 0.1 °C (maximum) from -20 °C to 50 °C
- ± 0.2 °C (maximum) from -40 °C to 100 °C
- ± 0.3 °C (maximum) from -55 °C to 150 °C



3.5 Dry Contact Probe (Model: LHT65N-DC)

- Design for Pulse Counting(Ext=8), Alarm (Ext=4), Open/Close Detect (Ext=4)
- 3 wires: VCC/GND/INT
- Cable Length: 1 meter



LHT65-DC can be used to connect various types of external sensor. below.

User can refer this link for the instructions: [LHT65-DC Connection Instruction](#).



Door Sensor



Water Leak



Level Detect



PIR



Flow Sensor



Laser Switch

3.6 Door Sensor (Model: LHT65N-DS)

- Aluminum Alloy Door Sensor
- Detect Distance: ~3cm
- Cable Length: 1 meter

Notice: When order LHT65N-DS, the device is by default set to: a) AT+EXT=4,1 ; b) Default Uplink Interval TDC is 12 hour.



3.6 NIS Certificate Probe (Model: LHT65N-NIS)

External Probe:

- Unique NIST Certificate for each probe
- External NIST Traceable probe with unique ID

Notice: AT+PID=1 is by default enable, so LHT65N will also uplink the probe ID to platform.



4. Configure LHT65N via AT command or LoRaWAN downlink

Use can configure LHT65N via AT Command or LoRaWAN Downlink.

- AT Command Connection: See [FAQ](#).
- LoRaWAN Downlink instruction for different platforms: [IoT LoRaWAN Server](#)

There are two kinds of commands to configure LHT65N, they are:

- [General Commands](#).

These commands are to configure:

1. General system settings like: uplink interval.
2. LoRaWAN protocol & radio-related commands.

They are the same for all Dragino Devices which supports DLWS-005 LoRaWAN Stack(Note**). These commands can be found on the wiki: [End Device Downlink Command](#)

• **Commands special design for LHT65N**

These commands are only valid for LHT65N, as below:

4.1 Set Transmit Interval Time

Feature: Change LoRaWAN End Node Transmit Interval.

AT Command: AT+TDC

Command Example	Function	Response
AT+TDC=?	Show current transmit Interval	30000 OK the interval is 30000ms = 30s
AT+TDC=60000	Set Transmit Interval	OK Set transmit interval to 60000ms = 60 seconds

Downlink Command: 0x01

Format: Command Code (0x01) followed by 3 bytes time value.

If the downlink payload=0100003C, it means set the END Node's Transmit Interval to 0x00003C=60(S), while type code is 01.

- **Example 1:** Downlink Payload: 0100001E // Set Transmit Interval (TDC) = 30 seconds
- **Example 2:** Downlink Payload: 0100003C // Set Transmit Interval (TDC) = 60 seconds

4.2 Set External Sensor Mode

Feature: Change External Sensor Mode.

AT Command: AT+EXT

Command Example	Function	Response	Downlink Com
AT+EXT=?	Get current external sensor mode	1 OK External Sensor mode =1	
AT+EXT=1	Set external sensor mode to 1		A201
AT+EXT=9	Set to external DS18B20 with timestamp		A209
AT+EXT=6	Set to external ADC Sensor(use with E2 Cable)		A206
AT+EXT=2	Set to external TMP117 Sensor(Since Firmware v1.3)		A202
AT+EXT=11	Set to external SHT31 Sensor (Since Firmware v1.4.1)		A20B
AT+EXT=4	Set to external Interrupt Mode(Since Firmware v1.3)		A204
AT+EXT=8	Set to external Counting Mode(Since Firmware v1.3)		A208
AT+EXT=10	Set to external E2 sensor (TMP117)with Unix Timestamp(Since firmware V1.3.2)		A20A

Response

Downlink Command: 0xA2

Total bytes: 2 ~ 5 bytes

Example:

- 0xA201: Set external sensor type to E1
- 0xA209: Same as AT+EXT=9
- 0xA20702003c: Same as AT+SETCNT=60

4.3 Enable/Disable uplink DS18B20 Temperature probe ID

Feature: If PID is enabled, LHT65N will send the DS18B20 temperature probe ID on:

- First Packet after OTAA Join
- Every 24 hours since the first packet.

PID is default set to disable (0)

Notice: This feature only valid when EXT=1 or EXT=9

AT Command:

Command Example	Function	Response
AT+PID=1	Enable PID uplink	OK

Downlink Command:

- **0xA800** --> AT+PID=0
- **0xA801** --> AT+PID=1

4.4 Set Password

Feature: Set device password, max 9 digits

AT Command: AT+PASSWORD

Command Example	Function	Response
AT+PASSWORD=?	Show password	123456 OK
AT+PASSWORD=999999	Set password	OK

Downlink Command:

No downlink command for this feature.

4.5 Quit AT Command

Feature: Quit AT Command mode, so user needs to input password again before use AT Commands.

AT Command: AT+DISAT

Command Example	Function	Response
AT+DISAT	Quit AT Commands mode	OK

Downlink Command:

No downlink command for this feature.

4.6 Set to sleep mode

Feature: Set device to sleep mode

- **AT+Sleep=0** : Normal working mode, device will sleep and use lower power when there is no LoRa message
- **AT+Sleep=1** : Device is in deep sleep mode, no LoRa activation happen, used for storage or shipping.

AT Command: AT+SLEEP

Command Example	Function	Response
AT+SLEEP	Set to sleep mode	Clear all stored sensor data...

OK

Downlink Command:

- There is no downlink command to set to Sleep mode.

4.7 Set system time

Feature: Set system time, unix format. [See here for format detail.](#)

AT Command:

Command Example	Function
AT+TIMESTAMP=1611104352	OK Set System time to 2021-01-20 00:59:12

Downlink Command:

0x306007806000 // Set timestamp to 0x(6007806000), Same as AT+TIMESTAMP=1611104352

4.8 Set Time Sync Mode

Feature: Enable/Disable Sync system time via LoRaWAN MAC Command (DeviceTimeReq), LoRaWAN server must support v1.0.3 protocol to reply this command.

SYNCMOD is set to 1 by default. If user want to set a different time from LoRaWAN server, user need to set this to 0.

AT Command:

Command Example	Function
AT+SYNCMOD=1	Enable Sync system time via LoRaWAN MAC Command (DeviceTimeReq)

Downlink Command:

0x28 01 // Same As AT+SYNCMOD=1
0x28 00 // Same As AT+SYNCMOD=0

4.9 Set Time Sync Interval

Feature: Define System time sync interval. SYNCTDC default value: 10 days.

AT Command:

Command Example	Function
AT+SYNCTDC=0x0A	Set SYNCTDC to 10 (0x0A), so the sync time is 10 days.

Downlink Command:

0x29 0A // Same as AT+SYNCTDC=0x0A

4.10 Get data

Feature: Get the current sensor data.

AT Command:

- **AT+GETSENSORVALUE=0** // The serial port gets the reading of the current sensor

- **AT+GETSENSORVALUE=1** // The serial port gets the current sensor reading and uploads it.

4.11 Print data entries base on page

Feature: Print the sector data from start page to stop page (max is 416 pages).

AT Command: AT+PDTA

Command Example	Function
AT+PDTA=1,3 Print page 1 to 3	8019500 19/6/26 16:48 1 2992 sht temp=28.21 sht hum=71.5 ds temp=27.31 8019510 19/6/26 16:53 1 2994 sht temp=27.64 sht hum=69.3 ds temp=26.93 8019520 19/6/26 16:58 1 2996 sht temp=28.39 sht hum=72.0 ds temp=27.06 8019530 19/6/26 17:03 1 2996 sht temp=27.97 sht hum=70.4 ds temp=27.12 8019540 19/6/26 17:08 1 2996 sht temp=27.80 sht hum=72.9 ds temp=27.06 8019550 19/6/26 17:13 1 2998 sht temp=27.30 sht hum=72.4 ds temp=26.68 8019560 19/6/26 17:22 1 2992 sht temp=26.27 sht hum=62.3 ds temp=26.56 8019570 8019580 8019590 80195A0 80195B0 80195C0 80195D0 80195E0 80195F0 OK

Downlink Command:

No downlink commands for feature

4.12 Print last few data entries

Feature: Print the last few data entries

AT Command: AT+PLDTA

Command Example	Function
AT+PLDTA=5 Print last 5 entries	Stop Tx and RTP events when read sensor data 1 19/6/26 13:59 1 3005 sht temp=27.09 sht hum=79.5 ds temp=26.75 2 19/6/26 14:04 1 3007 sht temp=26.65 sht hum=74.8 ds temp=26.43 3 19/6/26 14:09 1 3007 sht temp=26.91 sht hum=77.9 ds temp=26.56 4 19/6/26 14:15 1 3007 sht temp=26.93 sht hum=76.7 ds temp=26.75 5 19/6/26 14:20 1 3007 sht temp=26.78 sht hum=76.6 ds temp=26.43 Start Tx and RTP events OK

Downlink Command:

No downlink commands for feature

4.13 Clear Flash Record

Feature: Clear flash storage for data log feature.

AT Command: AT+CLRDTA

Command Example	Function	Response
AT+CLRDTA	Clear date record	Clear all stored sensor data...

OK

Downlink Command: 0xA3

- Example: 0xA301 // Same as AT+CLRDTA

4.14 Auto Send None-ACK messages

Feature: LHT65N will wait for ACK for each uplink, If LHT65N doesn't get ACK from the IoT server, it will consider the message doesn't arrive server and store it. LHT65N keeps sending messages in normal periodically. Once LHT65N gets ACK from a server, it will consider the network is ok and start to send the not-arrive message.

AT Command: AT+PNACKMD

The default factory setting is 0

Command Example	Function	Response
AT+PNACKMD=1	Poll None-ACK message	OK

Downlink Command: 0x34

- Example: 0x3401 // Same as AT+PNACKMD=1

4.15 Modified WMOD command for external sensor TMP117 or DS18B20 temperature alarm(Since firmware 1.3.0)

Feature: Set internal and external temperature sensor alarms.

Command Example	Function	Response
AT+WMOD=parameter1,parameter2,parameter3,parameter4	Set internal and external temperature sensor alarms	OK

AT+WMOD=parameter1,parameter2,parameter3,parameter4

Parameter 1: Alarm mode:

- 0): Cancel
- 1): Threshold alarm
- 2): Fluctuation alarm
- 3): Sampling multiple times and uplink together

Parameter 2: Sampling time. Unit: seconds, up to 255 seconds.

Note: When the collection time is less than 60 seconds and always exceeds the set alarm threshold, the sending interval will not be the collection time, but will be sent every 60 seconds.

Parameter 3 and parameter 4:

1): If Alarm Mode is set to 1: Parameter 3 and parameter 4 are valid, as before, they represent low temperature and high temperature.

Such as AT+WMOD=1,60,45,105, it means high and low temperature alarm.

2): If Alarm Mode is set to 2: Parameter 3 is valid, which represents the difference between the currently collected temperature and the last uploaded temperature.

Such as AT+WMOD=2,10,2,it means that it is a fluctuation alarm.

If the difference between the current collected temperature and the last Uplink is ± 2 degrees, the alarm will be issued.

3): If Alarm Mode is set to 3:

- **parameter1:** Set Working Mode to **Mode 3**
- **parameter2:** Set the temperature sampling mode to 1(1:DS18B20;2:TMP117;3: Internal GXHT30).
- **parameter3:** Sampling Interval is **60s**.
- **parameter4:** When there is **20** sampling dats, Device will send these data via one uplink. (max value is 60, means max 60 sampling in one uplink)
- **parameter5 & parameter6:** Temperature alarm range is **-16 to 32°C**,
- **parameter7:** 1 to enable temperature alarm, 0 to disable the temperature alarm. If alarm is enabled, a data will be sent immediately if temperate exceeds the Alarm range.

Downlink Command: 0xA5

0xA5 00 -- AT+WMOD=0.

0xA5 01 0A 11 94 29 04 -- AT+WMOD=1,10,45,105 (AT+WMOD = second byte, third byte, fourth and fifth bytes divided by 100, sixth and seventh bytes divided by 100)

0xA5 01 0A F9 C0 29 04 --AT+WMOD=1,10,-16,105(Need to convert -16 to -1600 for calculation, -1600 (DEC)=FFFFFFFFF9C0 (HEX) FFFFFFFFFF9C0 (HEX) +10000(HEX)=F9C0(HEX))

0xA5 02 0A 02 -- AT+WMOD=2,10,2 (AT+WMOD = second byte, third byte, fourth byte)

0xA5 03 01 00 3C 14 FF F0 00 20 01--AT+WMOD=3,1,60,20,-16,32,1

0xA5 FF -- After the device receives it, upload the current alarm configuration (FPORT=8). Such as 01 0A 11 94 29 04 or 02 0A 02.

4.16 Get Firmware Version Info(Since V1.4.0)

Feature: use downlink to get firmware version.

Downlink Command: 0x2601

Downlink Control Type	FPort	Type Code	Downlink payload size(bytes)
Get Firmware Version Info	Any	26	2

Device will reply with firmware version info, device info. frequency band info. detail please check device user manual.

0b 0140 01 ff 0c4e

Total 7 bytes Example(FPort=5):

Sensor model

0x0b: LHT65N

Firmware version

firm_ver=(bytes[1]&0x0f)+'.'+(bytes[2]>>4&0x0f)+'.'+(bytes[2]&0x0f);

Example: 0x0140=V1.4.0

Frequency Band:

- 0x01: EU868

- 0x02: US915
- 0x03: IN865
- 0x04: AU915
- 0x05: KZ865
- 0x06: RU864
- 0x07: AS923
- 0x08: AS923-1
- 0x09: AS923-2
- 0xa0: AS923-3

Subband

value 0x00 ~ 0x08

Example: 0xFF ---> " NULL"

Battery

Ex1: 0x0C4E(H) = 3150(D) = 3150mV =3.15V

Ex2: 0x0CF8(H) = 3320(D) = 3320mV =3.32V

4.17 Setting LEDAlarm

Feature: Setting LEDAlarm

The default factory setting is 0

Command Example	Function	Response
AT+LEDALARM=1	Setting LEDAlarm	OK

Downlink Command: 0x3601

Note: This alarm range is controlled by AT+ARTEMP. You need to set AT+WMOD=1 before use.

5. Battery & How to replace

5.1 Battery Type

LHT65N is equipped with a 2400mAH Li-MnO₂ (CR17505) battery . The battery is an un-rechargeable battery with low discharge rate targeting for up to 8~10 years use. This type of battery is commonly used in IoT devices for long-term running, such as water meters.

The discharge curve is not linear so can't simply use percentage to show the battery level. Below is the battery performance.

Performance

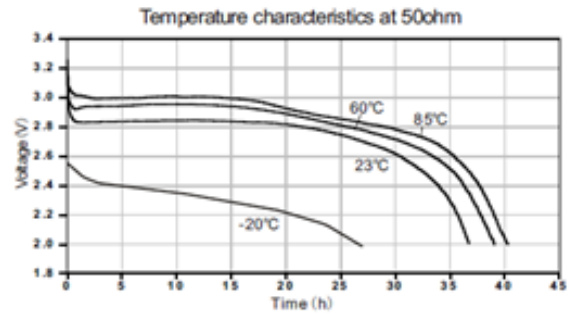
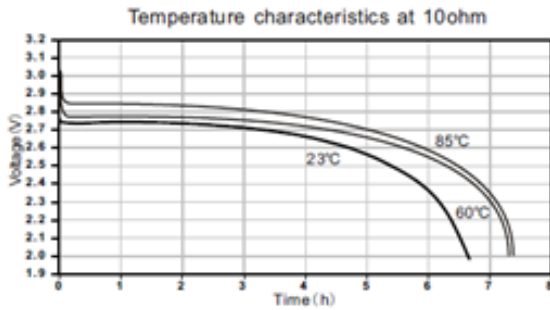

The minimum Working Voltage for the LHT65N is ~ 2.5v. When battery is lower than 2.6v, it is time to change the battery.

5.2 Replace Battery

LHT65N has two screws on the back, Unscrew them, and changing the battery inside is ok. The battery is a general CR17450 battery. Any brand should be ok.

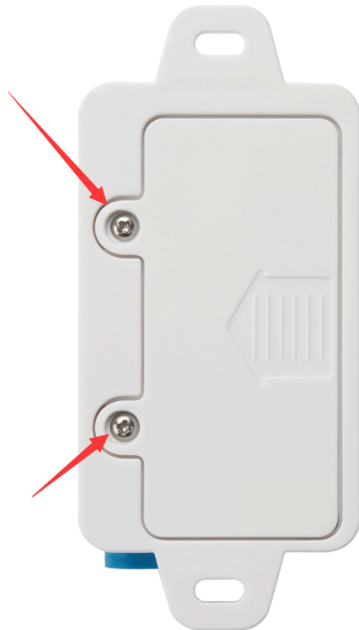

5.3 Battery Life Analyze

Dragino battery-powered products are all run in Low Power mode. User can check the guideline from this link to calculate the estimated battery life:

https://www.dragino.com/downloads/downloads/LoRa_End_Node/Battery_Analyze/DRAGINO_Battery_Life_Guide.pdf

A full detail test report for LHT65N on different frequency can be found at : <https://www.dropbox.com/sh/r2i3zlhsyrpavla/AAB1sZw3mdT0K7XjpHCITt13a?dl=0>

6. FAQ

6.1 How to connect to LHT65N UART interface?

The LHT65N has the UART interface in its Type-C. The UART Interface can be used for

- Send AT Commands, and get output from LHT65N
- Upgrade firmwre of LHT65N.

The hardware connection is: **PC <--> USB to TTL Adapter <--> Jump wires <--> Type-C Adapter <--> LHT65N**

Option of USB TTL adapter:

- CP2101 USB TTL Adapter
- CH340 USB TTL Adapter
- FT232 USB TTL Adapter

Option of Type-C Adapter:

User Manual for LoRaWAN /NB -IoT End Nodes - LHT65N
LoRaWAN Temperature & Humidity Sensor Manual

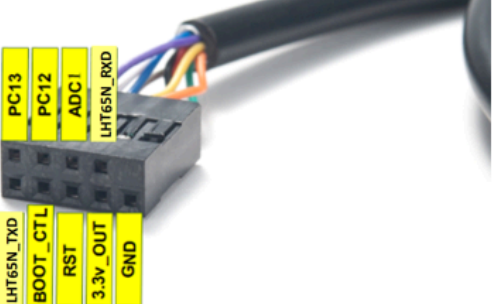
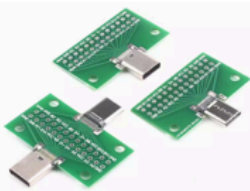
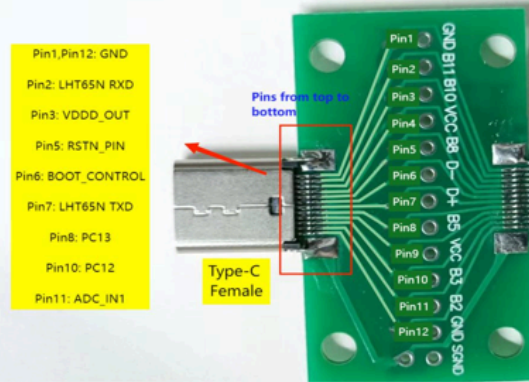
Description	Photo	Pin Out
E2 Extension Cable for LHT65N		
USB Type C extension Board		 <p>Pin1,Pin12: GND Pin2: LHT65N RXD Pin3: VDDD_OUT Pin5: RSTN_PIN Pin6: BOOT_CONTROL Pin7: LHT65N TXD Pin8: PC13 Pin10: PC12 Pin11: ADC_IN1</p> <p>Type-C Female</p> <p>Pins from top to bottom</p>

Connection:

- **USB to TTL GND <--> LHT65N GND**
- **USB to TTL RXD <--> LHT65N TXD**
- **USB to TTL TXD <--> LHT65N RXD**

Connection Example:

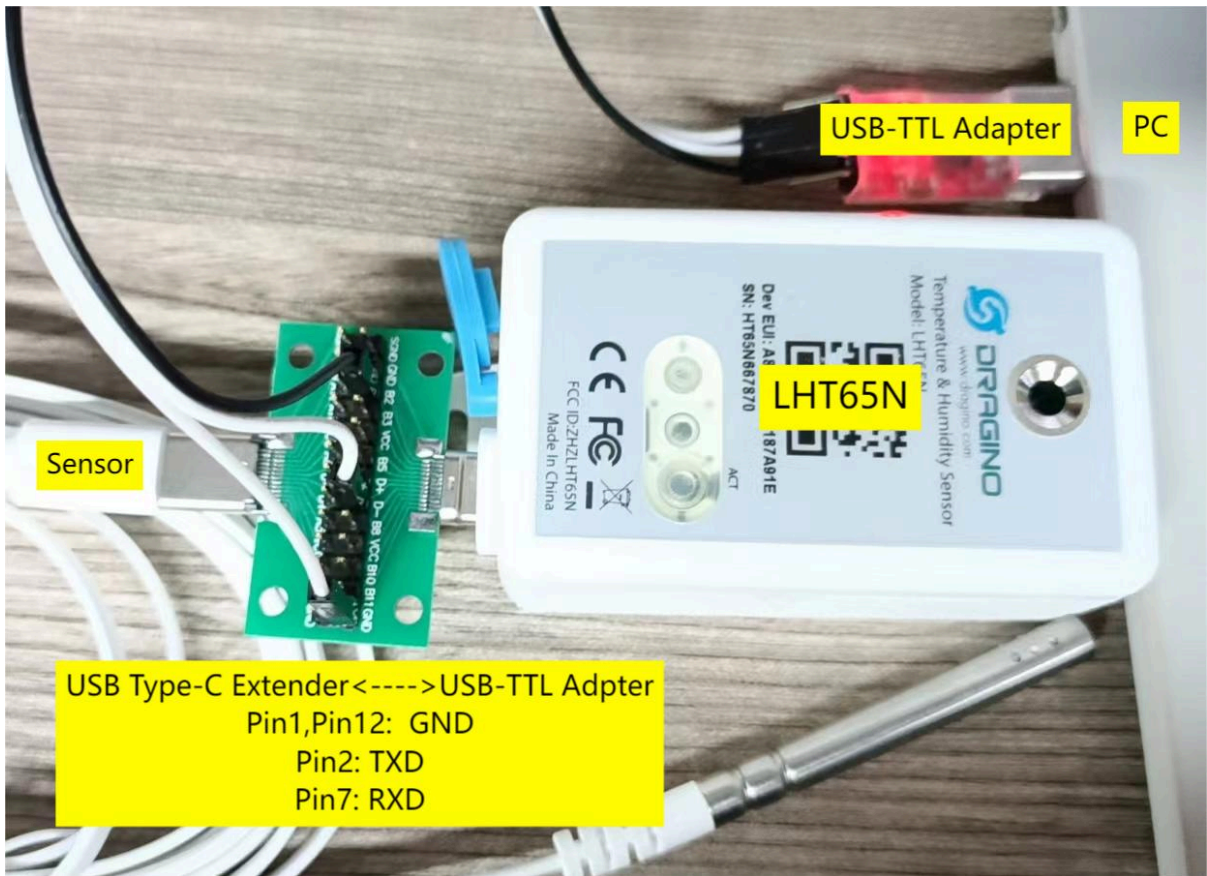
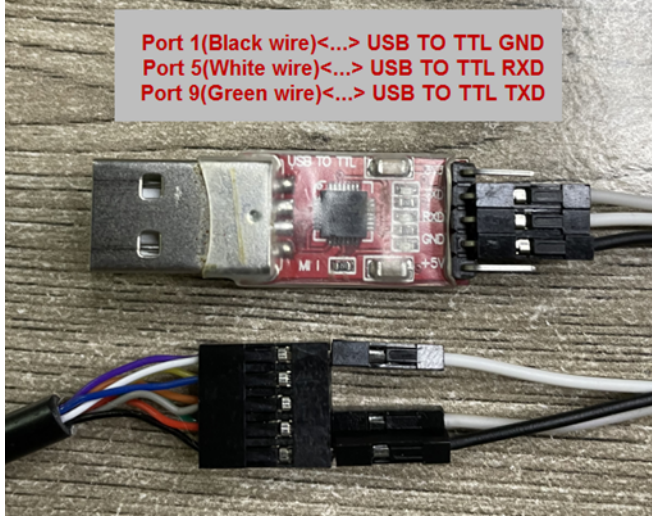

6.2 How to use AT Commands?

First, Connect PC and LHT65N via USB TTL adapter as **FAQ 6.1**

In PC, User needs to set serial tool(such as [putty](#), SecureCRT) baud rate to **9600** to access to access serial console for LHT65N. The AT commands are disable by default and need to enter password (default:**123456**) to

User Manual for LoRaWAN /NB -IoT End Nodes - LHT65N LoRaWAN Temperature & Humidity Sensor Manual

active it. Timeout to input AT Command is 5 min, after 5-minute, user need to input password again. User can use AT+DISAT command to disable AT command before timeout.

Input password and ATZ to activate LHT65N,As shown below:

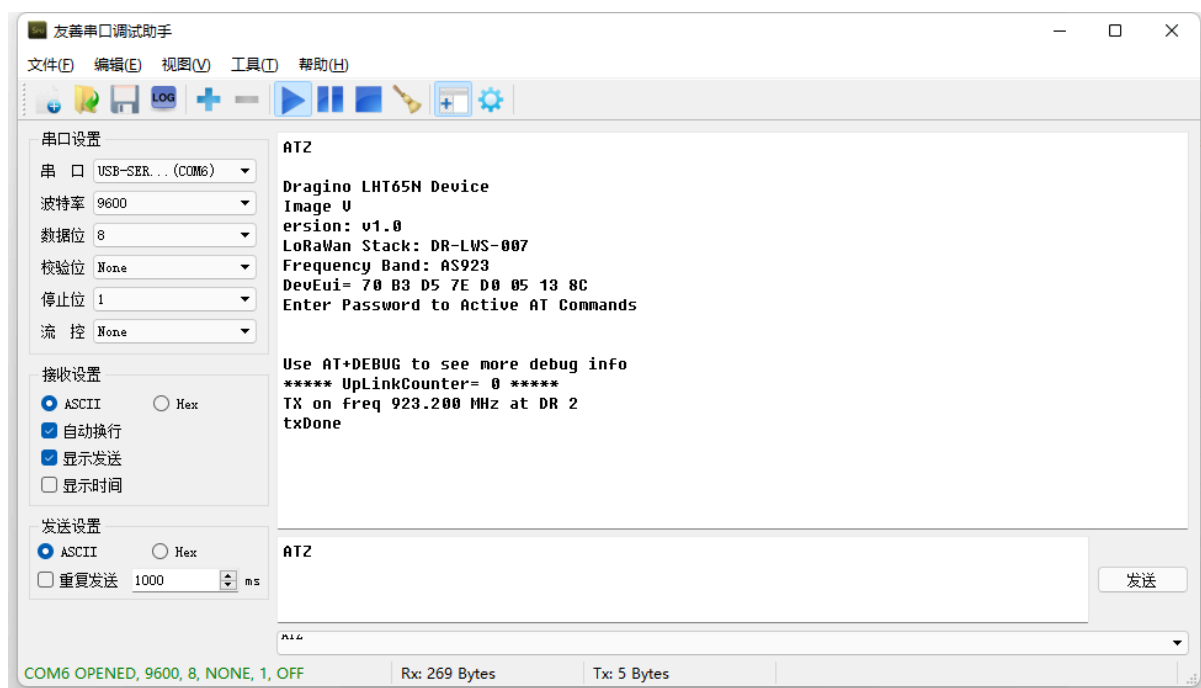

AT Command List is as below:

- AT+<CMD>? : Help on <CMD>
- AT+<CMD> : Run <CMD>
- AT+<CMD>=<value> : Set the value
- AT+<CMD>=? : Get the value
- AT+DEBUG: Set more info output
- ATZ: Trig a reset of the MCU
- AT+FDR: Reset Parameters to Factory Default, Keys Reserve
- AT+DEUI: Get or Set the Device EUI
- AT+DADDR: Get or Set the Device Address
- AT+APPKEY: Get or Set the Application Key
- AT+NWKSKEY: Get or Set the Network Session Key
- AT+APPSKEY: Get or Set the Application Session Key
- AT+APPEUI: Get or Set the Application EUI
- AT+ADR: Get or Set the Adaptive Data Rate setting. (0: off, 1: on)
- AT+TXP: Get or Set the Transmit Power (0-5, MAX:0, MIN:5, according to LoRaWAN Spec)
- AT+DR: Get or Set the Data Rate. (0-7 corresponding to DR_X)
- AT+DCS: Get or Set the ETSI Duty Cycle setting - 0=disable, 1=enable - Only for testing

User Manual for LoRaWAN /NB -IoT End Nodes - LHT65N
LoRaWAN Temperature & Humidity Sensor Manual

AT+PNM: Get or Set the public network mode. (0: off, 1: on)

AT+RX2FQ: Get or Set the Rx2 window frequency

AT+RX2DR: Get or Set the Rx2 window data rate (0-7 corresponding to DR_X)

AT+RX1DL: Get or Set the delay between the end of the Tx and the Rx Window 1 in ms

AT+RX2DL: Get or Set the delay between the end of the Tx and the Rx Window 2 in ms

AT+JN1DL: Get or Set the Join Accept Delay between the end of the Tx and the Join Rx Window 1 in ms

AT+JN2DL: Get or Set the Join Accept Delay between the end of the Tx and the Join Rx Window 2 in ms

AT+NJM: Get or Set the Network Join Mode. (0: ABP, 1: OTAA)

AT+NWKID: Get or Set the Network ID

AT+FCU: Get or Set the Frame Counter Uplink

AT+FCD: Get or Set the Frame Counter Downlink

AT+CLASS: Get or Set the Device Class

AT+JOIN: Join network

AT+NJS: Get the join status

AT+SENB: Send hexadecimal data along with the application port

AT+SEND: Send text data along with the application port

AT+RECVB: Print last received data in binary format (with hexadecimal values)

AT+RECV: Print last received data in raw format

AT+VER: Get current image version and Frequency Band

AT+CFM: Get or Set the confirmation mode (0-1)

AT+CFS: Get confirmation status of the last AT+SEND (0-1)

AT+SNR: Get the SNR of the last received packet

AT+RSSI: Get the RSSI of the last received packet

AT+TDC: Get or set the application data transmission interval in ms

AT+PORT: Get or set the application port

AT+DISAT: Disable AT commands

AT+PASSWORD: Set password, max 9 digits

AT+CHS: Get or Set Frequency (Unit: Hz) for Single Channel Mode

AT+CHE: Get or Set eight channels mode, Only for US915, AU915, CN470

AT+PDTA: Print the sector data from start page to stop page

AT+PLDTA: Print the last few sets of data

AT+CLRDTA: Clear the storage, record position back to 1st

AT+SLEEP: Set sleep mode

AT+EXT: Get or Set external sensor model

AT+BAT: Get the current battery voltage in mV

AT+CFG: Print all configurations

AT+WMOD: Get or Set Work Mode

AT+ARTEMP: Get or set the internal Temperature sensor alarm range

AT+CITEMP: Get or set the internal Temperature sensor collection interval in min

AT+SETCNT: Set the count at present

AT+RJTDC: Get or set the ReJoin data transmission interval in min

AT+RPL: Get or set response level

AT+TIMESTAMP: Get or Set UNIX timestamp in second

AT+LEAPSEC: Get or Set Leap Second

AT+SYNCMOD: Get or Set time synchronization method

AT+SYNCTDC: Get or set time synchronization interval in day

AT+PID: Get or set the PID

6.3 How to use Downlink commands?

Downlink commands:

TTN:

User Manual for LoRaWAN /NB -IoT End Nodes - LHT65N

LoRaWAN Temperature & Humidity Sensor Manual

Applications > lht111 > End devices > eui-a84041ffff1234dd



eui-a84041ffff1234dd

ID: eui-a84041ffff1234dd

↑ 156 ↓ 156 • Last activity 13 days ago ⓘ

Overview Live data **Messaging** Location Payload formatters General settings

Uplink **Downlink**

Schedule downlink

Insert Mode

- Replace downlink queue
- Push to downlink queue (append)

FPort *

Payload type

- Bytes
- JSON

Payload

The desired payload bytes of the downlink message

- Confirmed downlink

Schedule downlink

Helium:

User Manual for LoRaWAN /NB -IoT End Nodes - LHT65N
LoRaWAN Temperature & Humidity Sensor Manual

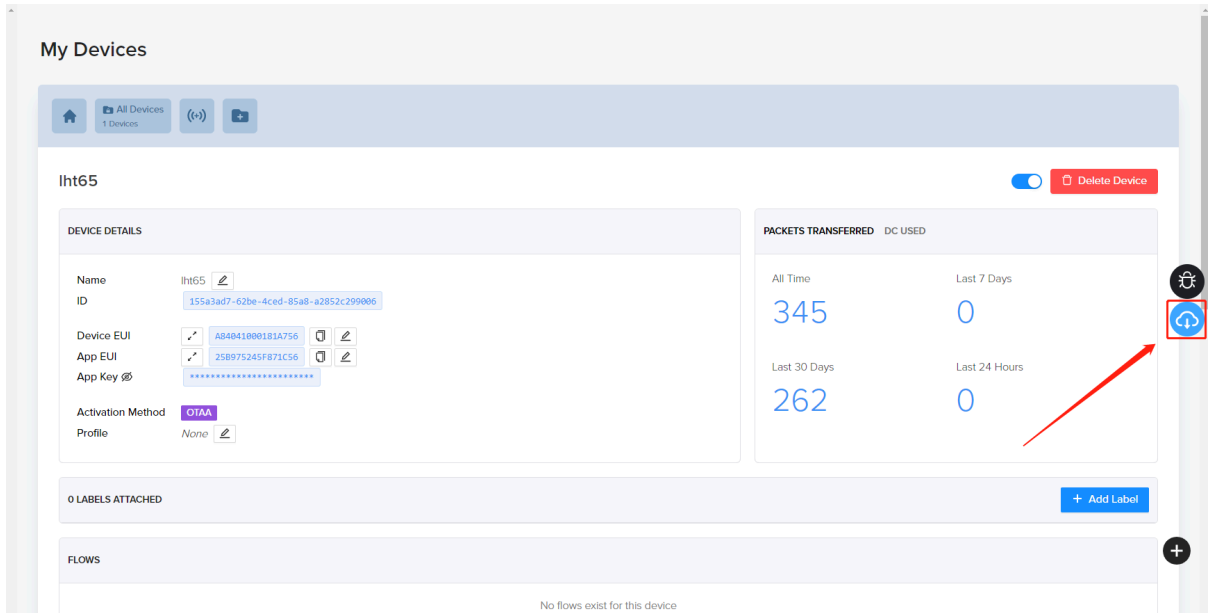

Chirpstack: The downlink window will not be displayed until the network is accessed

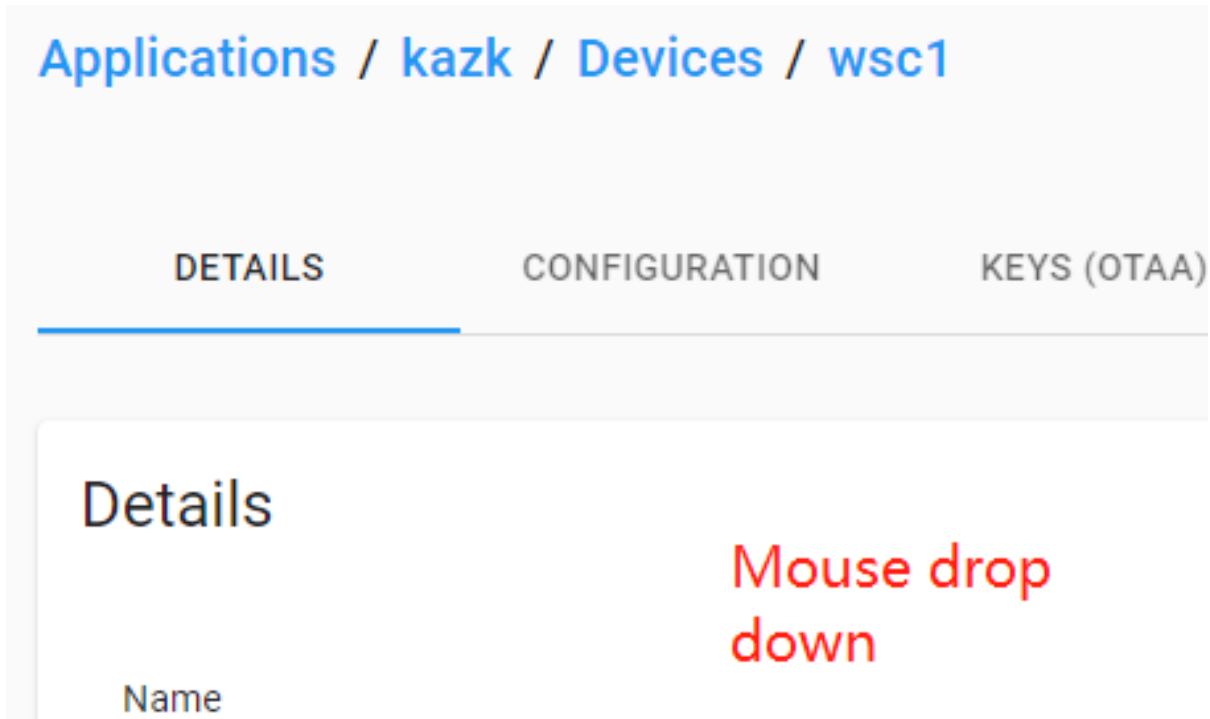

User Manual for LoRaWAN /NB -IoT End Nodes - LHT65N

LoRaWAN Temperature & Humidity Sensor Manual

Enqueue downlink payload

Port *

Please note that the FPort value must be > 0.

Confirmed downlink

BASE64 ENCODED JSON OBJECT

Base64 encoded string *

[ENQUEUE PAYLOAD](#)

AWS-IOT :

The screenshot displays the AWS IoT console interface. On the left is a navigation sidebar with categories like 'Test', 'manage', and 'Device software'. The main content area is divided into several sections:

- Device traffic:** A table showing gateway connection details.
- Configuration file:** A section for device profiles and service configuration files.
- Downlink message queue (0):** A section with buttons for 'Clear the downlink queue', 'Delete', and 'Downlink messages are queued'. Below it is a table with columns for 'The message ID', 'timestamp', 'FPort', and 'TransmitMode'. The table is currently empty, displaying a 'No downlink message' message.
- label:** A section for managing tags, currently showing 'No labels' and a message 'You don't have any tags attached to this resource.'

The footer of the console shows a feedback link, a search bar, and copyright information for Amazon Web Services, Inc. or its affiliates.

6.4 How to change the uplink interval?

Please see this link: <http://wiki.dragino.com/xwiki/bin/view/Main/How%20to%20set%20the%20transmit%20time%20interval/>

6.5 How to upgrade firmware?

The firmware **before V1.4** does not have wireless upgrade function, and the starting address of the firmware is **0x08000000**.

Since and including V1.4, LHT65N supports wireless upgrade, and its firmware is divided into **bootloader + working firmware**. Burning bootloader selects address **0x08000000**, and burning working firmware selects address **0x0800D000**.

LHT65N has two types of firmware: **Firmware with bootloader** and **Firmware without bootloader**. [Firmware Download Link](#):

Use UART connection to update the firmware, detailed description of UART refer to [FAQ 6.1](#), Connection Example:

Note: To use the TremoProgrammer the node must be put into burn mode, i.e. the USB-TTL adapter 3.3V must be connected to the BOOT_CONTROL pin of the LHT65N.

- For the connection **E2 cable <----> USB-TTL adapter**:

Port 4(Blue wire)<---->USB-TTL 3V3

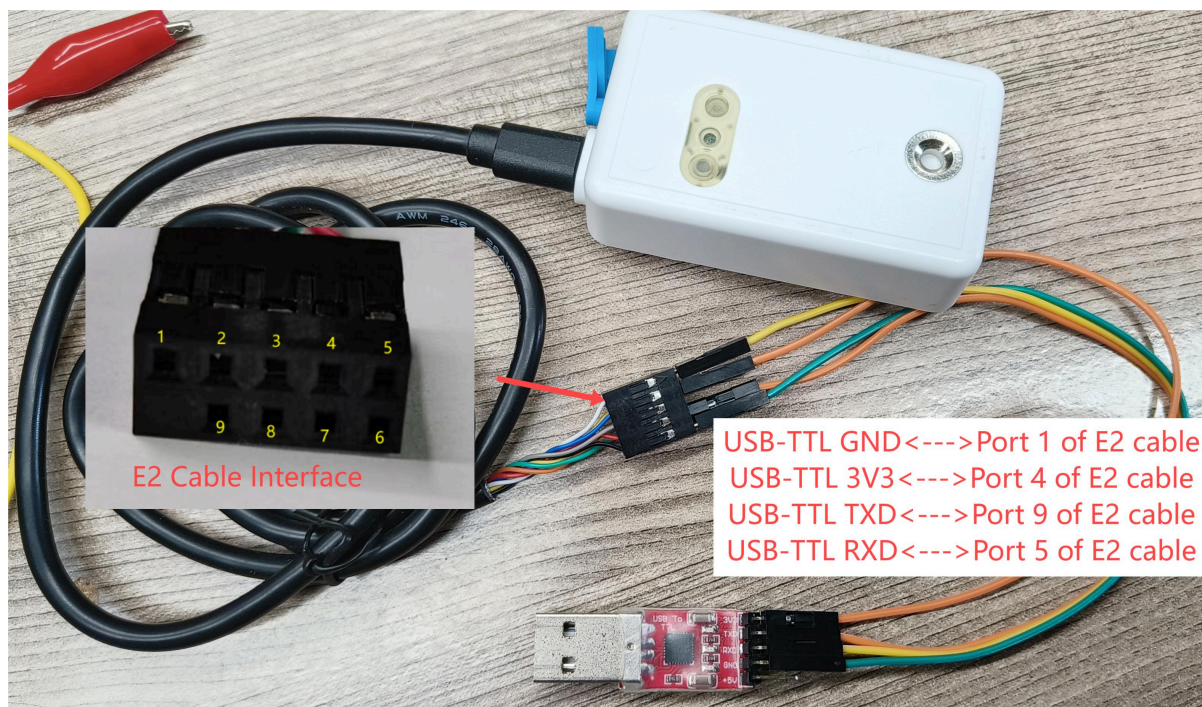

- For the connection **USB Type-C Extender<---->USB-TTL adapter**:

Pin 6<---->USB-TTL 3V3

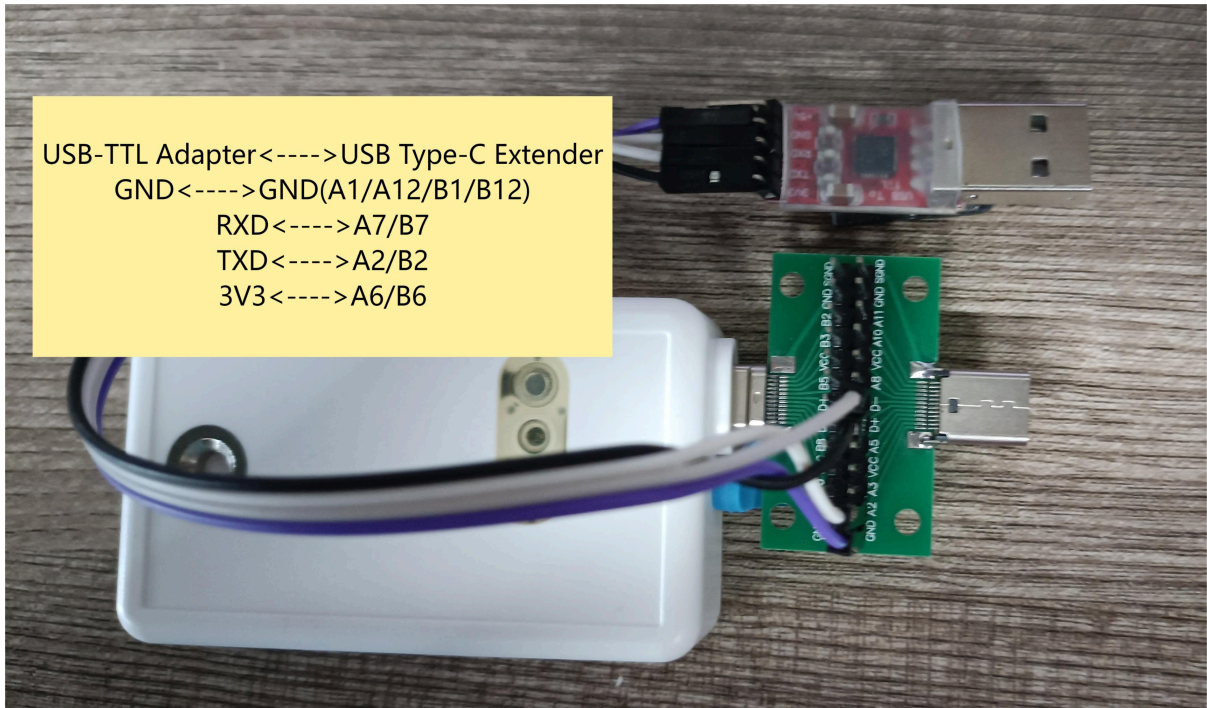

6.5.1 Burning firmware before V1.3 (including V1.3)

Burning firmware prior to and including V1.3 can only be done using the [TremoProgrammer](#), select the burn address: 0x08000000

According to the above instructions to **enter the burning mode**, re-install the battery to **reset the node**, press the ACT button LED does not light up, the node successfully entered the burning mode, **click "START"**.

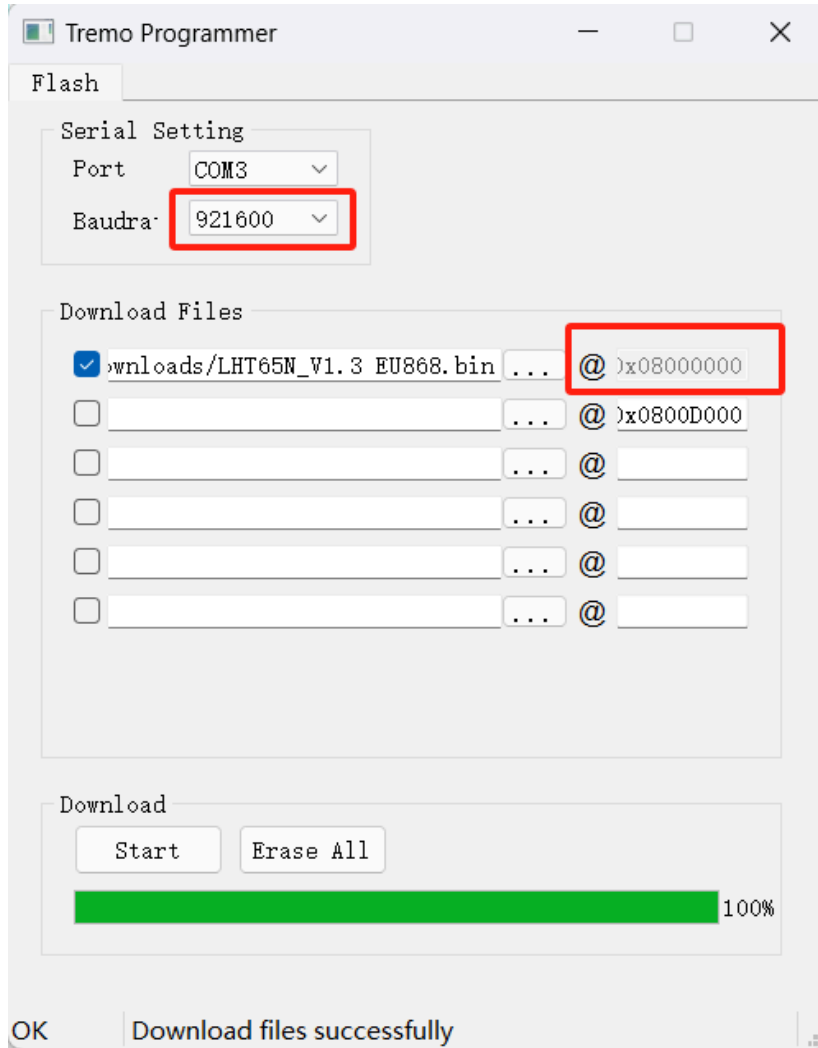

6.5.2 Updated firmware for V1.4 and above

Updating firmware version V1.4 and above requires distinguishing whether the firmware comes with a bootloader or not.

- For version V1.4 and above, we ship nodes with bootloader, users can directly choose firmware without bootloader to upgrade directly. Use **TremoProgrammer** to start at address **0x0800D000**. Using **Dragino Sensor Manager Utility.exe** does not require address selection, but must use firmware without bootloader.
- For nodes where the bootloader was accidentally erased, customers need to burn the bootloader and working firmware using **TremoProgrammer**.

The firmware of V1.4 and above updated on our official website will note whether it comes with bootloader or not, customers need to choose the appropriate update method according to the firmware type.

6.5.2.1 Update firmware (Assume device already have bootloader)

Step1 : Connect UART as per FAQ 6.1

Step2 : Update follow [Instruction for update via DraginoSensorManagerUtility.exe](#). Make sure to use the firmware without bootloader.

(Recommended way) OTA firmware update via wireless : <http://wiki.dragino.com/xwiki/bin/view/Main/Firmware%20OTA%20Update%20for%20Sensors/>

6.5.2.2 Update firmware (Assume device doesn't have bootloader)

In this update method, make sure to use the firmware with bootloader , [Download Link](#) . After update , device will have bootloader so can use above method(6.5.2.1) to update.

Step1: Install [TremoProgrammer](#) first.



Step2: Hardware Connection

Connect PC and LHT65N via USB TTL adapter .

Note: Burn mode: Port4 (BOOT_CTL) of E2 cable connects 3V3 of USB-TTL.

Connection method:

USB-TTL GND <--> Port 1 of E2 cable

USB-TTL 3V3 <--> Port 4 of E2 cable

USB-TTL TXD <--> Port 9 of E2 cable

USB-TTL RXD <--> Port 5 of E2 cable

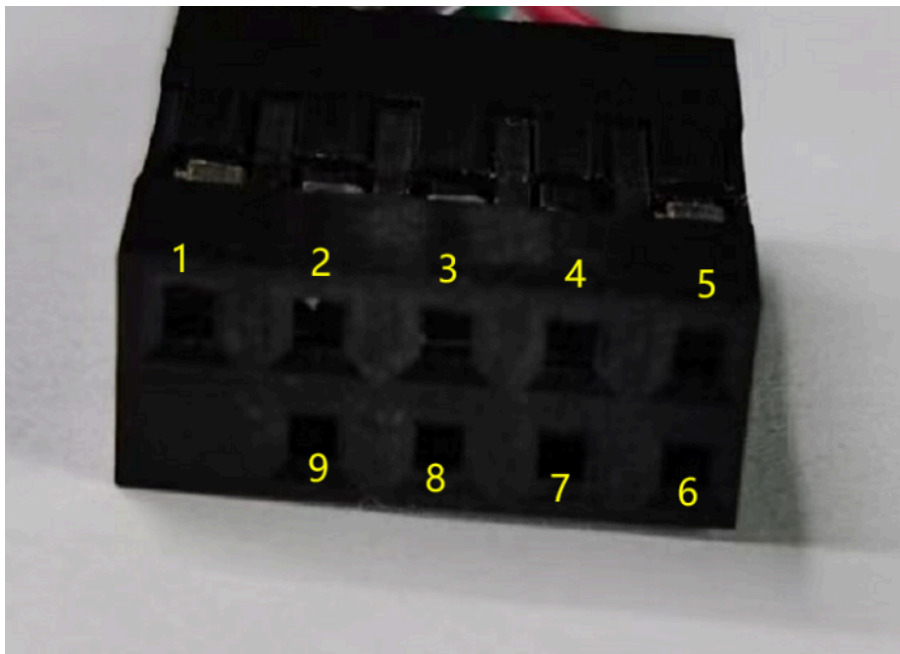

Step3: Select the device port to be connected, baud rate and bin file to be downloaded.

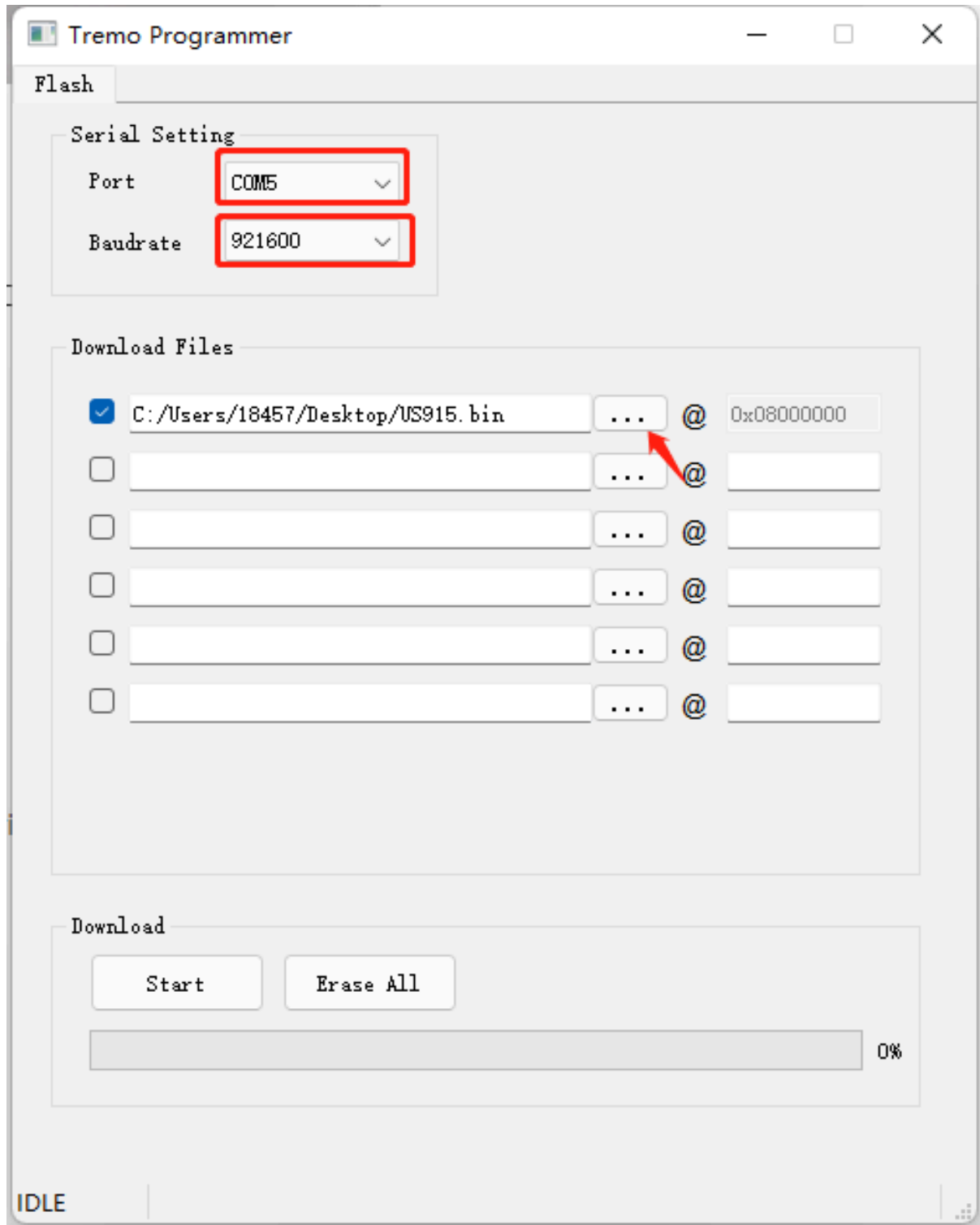

Reset node: Short-circuit the port3(RST) of the E2 cable to GND. /The new motherboard cancels the RST, and the **battery needs to be reinstalled** to achieve the reset effect.

Then click the **start** button to start the firmware upgrade.

When this interface appears, it indicates that the download has been completed.

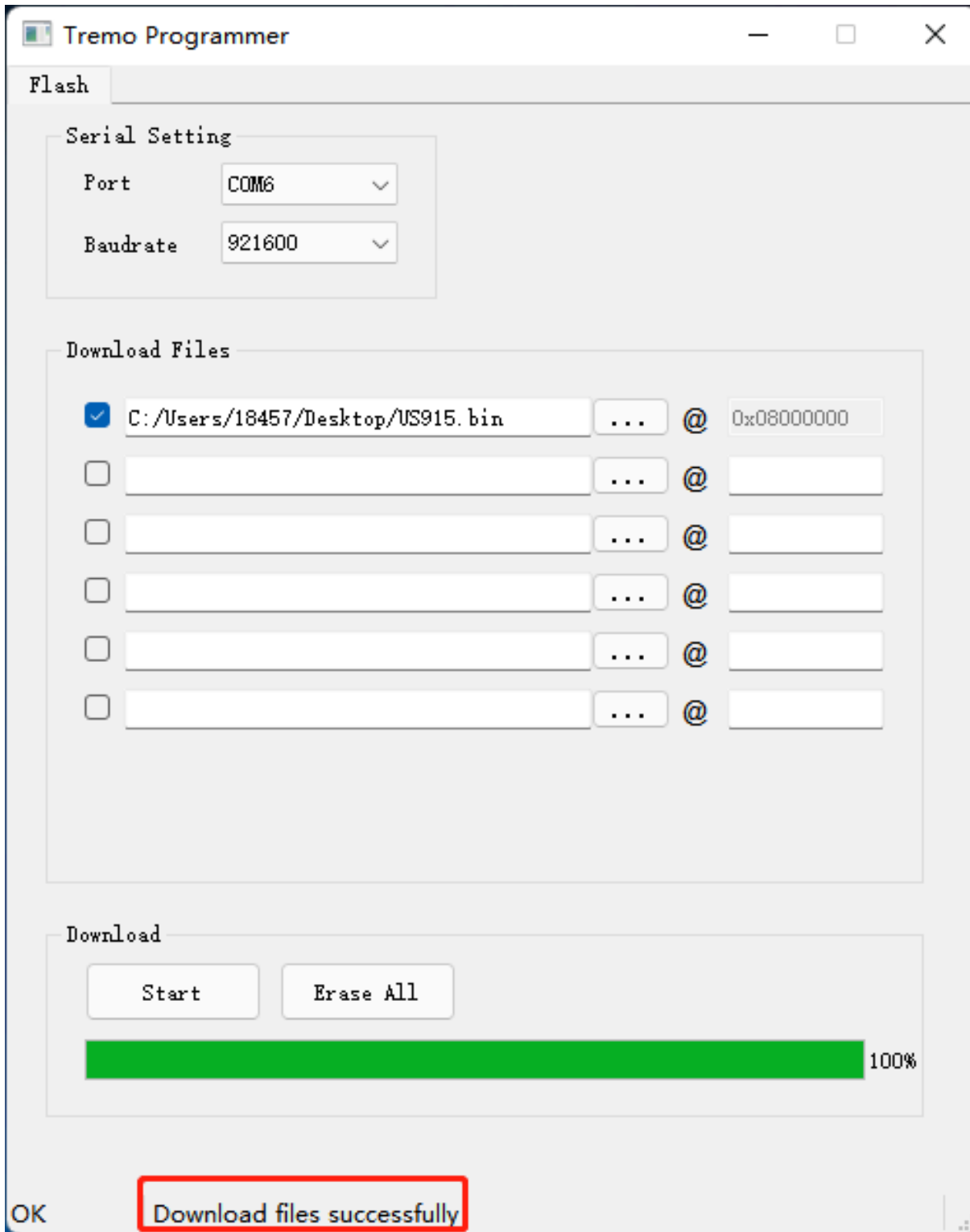

Finally, Disconnect Port4 of E2 cable, reset the node again (Port3 shorted GND/ /The new motherboard cancels the RST, and the **battery needs to be reinstalled** to achieve the reset effect.), and the node exits burning mode.

6.6 Why can't I see the datalog information

1. The time is not aligned, and the correct query command is not used.
2. Decoder error, did not parse the datalog data, the data was filtered.

6.7 How can i read sensor data without LoRaWAN? For Calibration Purpose

Some clients need to calibrate the sensor value in calibration Lab. In such case, Reading the data without LoRaWAN network is more convinient. To achieve this, use can use a USB Type-C Breakout board to expose the UART pins while still have the probe connected. See below. Detail Pin out please refer the FAQ of [how to connect UART](#)



After there is UART Connectio, run below commands:

1. **AT+NJM=0** // Set Device to ABP mode , so can works without join to LoRaWAN server.
2. **AT+GETSENSORVALUE=0** //The serial port gets the reading of the current sensor.

Example output:

```
[Tx][17:09:49.078] AT+GETSENSORVALUE=0
[Rx][17:09:49.201] Bat_voltage=3.083 V
[Rx][17:09:49.201] Sht_temp=28.27 , Sht_hum=50.9
[Rx][17:09:49.201] Ext_Sht_temp=27.36 , Ext_Sht_hum=54.1
[Rx][17:09:49.241]
[Rx][17:09:49.241] OK
[Tx][17:09:52.862] AT+GETSENSORVALUE=0
[Rx][17:09:52.991] Bat_voltage=3.083 V
[Rx][17:09:52.991] Sht_temp=28.26 , Sht_hum=50.9
[Rx][17:09:52.991] Ext_Sht_temp=27.32 , Ext_Sht_hum=53.9
[Rx][17:09:53.021]
[Rx][17:09:53.021] OK
```

7. Order Info

Part Number: **LHT65N-XX-YY**

XX : The default frequency band

- **AS923**: LoRaWAN AS923 band
- **AU915**: LoRaWAN AU915 band
- **EU433**: LoRaWAN EU433 band
- **EU868**: LoRaWAN EU868 band
- **KR920**: LoRaWAN KR920 band
- **US915**: LoRaWAN US915 band
- **IN865**: LoRaWAN IN865 band
- **CN470**: LoRaWAN CN470 band

YY: Sensor Accessories

- **E3**: External Temperature Probe

8. Packing Info

Package Includes:

- LHT65N Temperature & Humidity Sensor x 1
- Optional external sensor

9. Reference material

- [Datasheet, photos, decoder, firmware](#)

10. FCC Warning

This device complies with part 15 of the FCC Rules. Operation is subject to the following two conditions:

- (1) This device may not cause harmful interference;
- (2) this device must accept any interference received, including interference that may cause undesired operation.