TrackerD -- LoRaWAN Tracker User Manual

last modified by Xiaoling

on 2025/04/07 17:16

Table of Contents

1. Introduction	5
1.1 What is TrackerD	5



Table of Contents:

- [1. Introduction](#)
 - [1.1 What is TrackerD](#)
 - [1.2 Specifications](#)
 - [1.3 Features](#)
 - [1.4 Applications](#)
- [2. Use TrackerD](#)
 - [2.1 How it works?](#)
 - [2.2 Quick guide to connect to LoRaWAN server](#)
 - [2.3 Positioning Mode\(SMOD\)](#)
 - [2.4 Uplink Payload](#)
 - [2.4.1 Uplink FPORT=5, Device Status](#)
 - [2.4.2 Uplink FPORT=2, Realtime GNSS Positioning + Temperature & Humidity](#)
 - [Alarm & BAT:](#)
 - [FLAG:](#)
 - [Location info:](#)
 - [Alarm:](#)
 - [BAT:](#)
 - [MOD:](#)
 - [LON:](#)
 - [Hum:](#)
 - [Tem:](#)
 - [2.4.3 Uplink FPORT=3, Realtime GNSS Positioning \(Default Mode\)](#)
 - [2.4.4 Uplink FPORT=4, History GNSS Positioning](#)
 - [2.4.5 Uplink FPORT=6, BLE Positioning with Strongest iBeacon](#)
 - [2.4.6 Uplink FPORT=7, Alarm information status \(Since firmware 1.4.4\)](#)
 - [2.4.7 Uplink FPORT=8, WiFi Positioning with Strongest WiFi SSID \(Since firmware 1.4.1\)](#)
 - [2.4.8 Uplink FPORT=9, BLE Positioning with Multiple iBeacon\(Since firmware 1.4.7\)](#)
 - [2.4.9 Add Payload format in TTN V3](#)
 - [2.5 Integrate with Datalog](#)
 - [2.6 Integrate with Tago](#)
 - [2.7 Integrate with Node-red](#)
 - [2.8 Datalog Feature](#)
 - [2.9 Alarm Mode](#)
 - [2.10 Transport Mode](#)
 - [2.11 LED Status](#)
 - [2.12 Button Function](#)
 - [2.13 USB Port Function](#)
 - [2.14 Sleep Mode](#)

- [3. Configure TrackerD via AT command or LoRaWAN downlink](#)
 - [3.1 Access AT Command](#)
 - [3.2 Command Set](#)
 - [3.2.1 Set Transmit Interval](#)
 - [3.2.2 Set Alarm Packet transmission interval](#)
 - [3.2.3 Set Transport Mode Packet transmission interval](#)
 - [3.2.4 Exit Alarm](#)
 - [3.2.5 Disable/Enable LED flash and buzzer](#)
 - [3.2.6 Disable/Enable Transport Mode](#)
 - [3.2.7 Set Positioning Mode](#)
 - [3.2.8 Set MAX GPS position time](#)
 - [3.2.9 Set PDOP value for GPS fix accuracy](#)
 - [3.2.10 Disable/Enable the confirmation mode](#)
 - [3.2.11 Auto Send None-ACK messages](#)
 - [3.2.12 Set BLEMASK to filter BLE iBeacon](#)
 - [3.2.13 Set WiFIMASK to filter WiFi SSID\(Since firmware 1.4.1\)](#)
 - [3.2.14 Disable/Enable Information printing\(Since firmware 1.4.1\)](#)
 - [3.2.15 Get or Set Eight Channels Mode, only for us915, AU915\(Since firmware 1.4.1\)](#)
 - [3.2.16 Get or Set Threshold for motion detect\(Since firmware 1.4.3\)](#)
 - [3.2.17 Set AT command window time\(Since firmware 1.4.5\)](#)
 - [3.2.18 Set the stepmeter mode\(Since firmware 1.4.5\)](#)
 - [3.2.19 Set down the decline detection mode\(Since firmware 1.4.5\)](#)
 - [3.2.20 Disable/Enable buzzer\(Since firmware 1.4.6\)](#)
 - [3.2.21 Set long press time\(Since firmware 1.4.6\)](#)
 - [3.2.22 Set the Bluetooth scan time\(Since firmware 1.5.1\)](#)
 - [3.2.23 Conversion of TrackerD and TrackerD-LS\(Since firmware 1.4.9\)](#)
- [4. Setting for Different Scenarios](#)
- [5. Upload Firmware](#)
 - [5.1 Firmware Change Log](#)
 - [5.2 How to upgrade firmware](#)
- [6. Developer Guide](#)
 - [6.1 Compile Source Code](#)
 - [6.1.1 Set up ARDUINO compile environment](#)
 - [6.1.2 Build the development environment](#)
 - [6.2 Source Code](#)
- [7. FAQ](#)
 - [7.1 How to change the LoRa Frequency Bands/Region?](#)
 - [7.2 What is the pin mapping for the USB program cable?](#)
 - [7.3 Notes on using different serial port tools for TrackerD](#)
 - [7.3.1 Serial port utility](#)
 - [7.3.2 SecureCRT](#)
 - [7.3.3 PUTTY](#)
 - [7.4 How to modify source code to compile different frequency band bin file?](#)
 - [7.5 Are there example python example for BLE Indoor Positioning?](#)
 - [7.6 Can alert mode and transport mode be used together?](#)
 - [7.7 Can i get the datalog record from console?](#)
 - [7.8 FAQs for upgrading to version 1.4.9 or later](#)
- [8 Trouble Shooting](#)
 - [8.1 TDC is changed to 4294947296 and cause no uplink.](#)
 - [8.2 Device not able get AT Command or show output after wake up from deep sleep mode](#)
 - [8.3 Problem after Upgrading Firmware](#)
 - [8.3.1 "rst: \(0x3 SW_RESET\)" and Continue Restart after upgrading](#)
 - [8.3.2 TrackerD's led light is always GREEN on after upgrading](#)
 - [8.3.3 "flash read err" after upgrade firmware](#)
 - [8.3.4 "Device Key become ff ff ff ff ff ff ff " after upgrade firmware](#)
 - [8.4 When positioning, it will restart or the PDOP setting is unsuccessful](#)
 - [8.5 How to deal with unsuccessful GPS positioning?](#)
 - [8.6 When upgrading the firmware, the data is not completely erased, and the information does not return to normal after multiple resets](#)
 - [8.7 If you encounter the following problems, please upgrade to the latest version](#)

- [8.8 Why when using some serial consoles, only inputting the first string port console will return "error"?](#)
- [8.9 When the device is connected to the serial port, it cannot send Uplink, the light color is abnormal, and it does not respond to commands.](#)
- [9. Order Info](#)
- [10. Packing Info](#)
- [11. Support](#)
- [12. Reference](#)

1. Introduction

1.1 What is TrackerD

TrackerD is an **Open Source LoRaWAN Tracker** based on **ESP32 MCU** and **Semtech LoRa Wireless Chip**.

In TrackerD, there are various sensors such as GPS, WiFi, BLE, Temperature, Humidity, Motion Detection, and Buzzer. User can use TrackerD for different tracking scenario.

TrackerD is program friendly. Developers can use Arduino IDE to customize the software of TrackerD to fit their IoT solution.

The LoRa wireless technology used in TrackerD allows the user to send data and reach extremely long ranges at low data-rates. It provides ultra-long range spread spectrum communication and high interference immunity whilst minimizing current consumption. It targets professional tracking services.

TrackerD is equipped with a **1000mAh Li-ion rechargeable battery**. Each TrackerD has a worldwide unique OTAA keys to join the LoRaWAN network.

TrackerD in a LoRaWAN Network

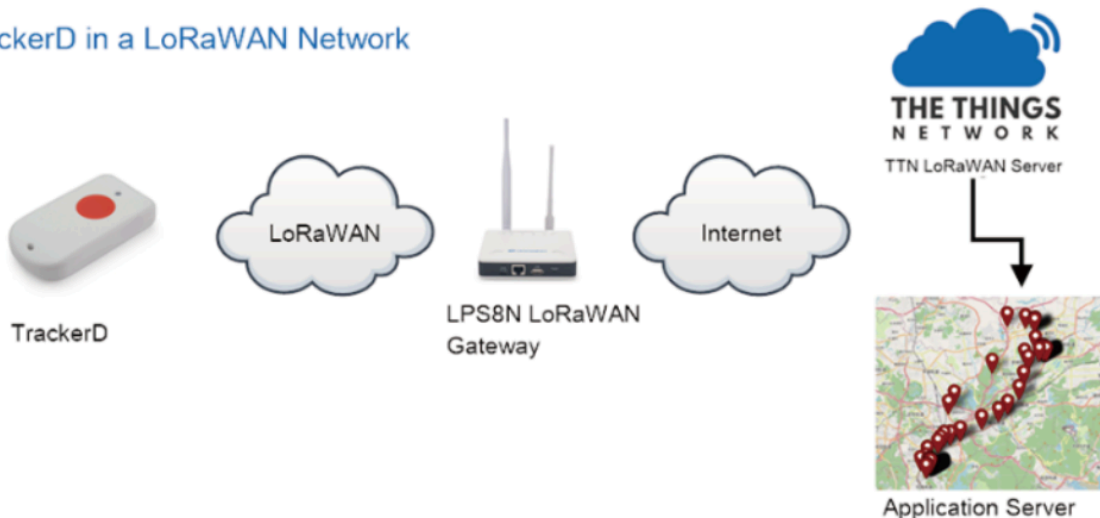

Note: LoRaWAN server can be a general LoRaWAN server other than TTN.

1.2 Specifications

Micro Controller:

- Espressif ESP32 PICO D4
- MCU: ESP32 PICO D4
- Bluetooth: Bluetooth V4.2 BR/EDR and Bluetooth LE
- WiFi : 802.11 b/g/n (802.11n up to 150 Mbps)
- Integrated SPI flash : 4 MB
- RAM: 448 KB
- EEPROM: 520 KB
- Clock Speed: 32Mhz

Common DC Characteristics:

- Supply Voltage: 5V via USB port or Internal li-on battery
- Operating Temperature: -15°C ~ 60°C

LoRa Spec:

- Frequency Range,
 - Band 1 (HF): 862 ~ 1020 Mhz
- 168 dB maximum link budget.
- +20 dBm - 100 mW constant RF output vs.
- +14 dBm high efficiency PA.
- Programmable bit rate up to 300 kbps.
- High sensitivity: down to -148 dBm.
- Bullet-proof front end: IIP3 = -12.5 dBm.
- Excellent blocking immunity.
- Low RX current of 10.3 mA, 200 nA register retention.
- Fully integrated synthesizer with a resolution of 61 Hz.
- FSK, GFSK, MSK, GMSK, LoRaTM and OOK modulation.
- Built-in bit synchronizer for clock recovery.
- Preamble detection.
- 127 dB Dynamic Range RSSI.
- Automatic RF Sense and CAD with ultra-fast AFC.
- Packet engine up to 256 bytes with CRC.
- LoRaWAN 1.0.3 Specification

Battery:

- 1000mA Li-ion Battery power (for model TrackerD)

Power Consumption

- Sleeping Mode: 200uA
- LoRa Transmit Mode: 125mA @ 20dBm 44mA @ 14dBm
- Tracking: max: 38mA

1.3 Features

- LoRaWAN 1.0.3 Class A
- ESP32 PICO D4
- SX1276/78 Wireless Chip
- Arduino IDE Compatible
- Open source hardware / software
- Regular/ Real-time GPS,BLE,WIFI tracking
- Built-in3 axis accelerometer (LIS3DH)
- Humidity / temperature sensor : GXCAS Technology GXHT3X
- Motion sensing capability
- Power Monitoring

- Charging circuit via USB port
- 1000mA Li-ion Battery power
- Tri-color LED, Alarm button
- Datalog

1.4 Applications

- Logistics and Supply Chain Management
- Human tracking

2. Use TrackerD

2.1 How it works?

TrackerD is configured as LoRaWAN OTAA Class A GPS tracker by default. It has OTAA keys to join LoRaWAN network. To connect a LoRaWAN network, user need to input the OTAA keys in the LoRaWAN IoT server and push reset button of TrackerD (next to USB port). TrackerD will wake up and auto join the network via OTAA.

2.2 Quick guide to connect to LoRaWAN server

Here is an example for how to join the [TTNv3 LoRaWAN Network](#). Below is the network structure, we use LPS8N as LoRaWAN gateway in this example.

TrackerD in a LoRaWAN Network

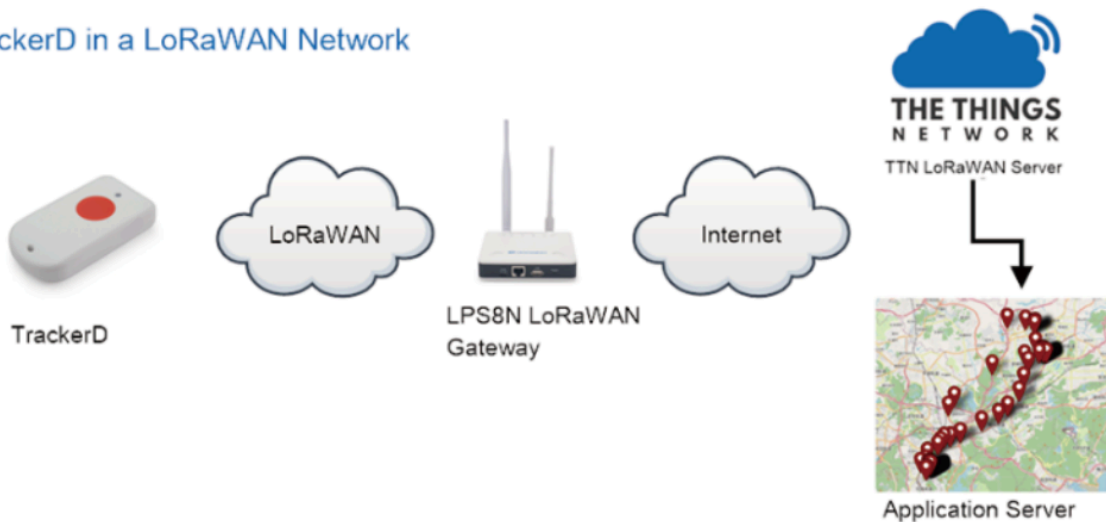

The LPS8N is already set to connect to [TTN V3 network](#). What the rest need to is register this device in TTN V3:

Step 1: Create a device in TTN V3 with the OTAA keys from TrackerD.

Each TrackerD is shipped with a sticker with the default device EUI as below:

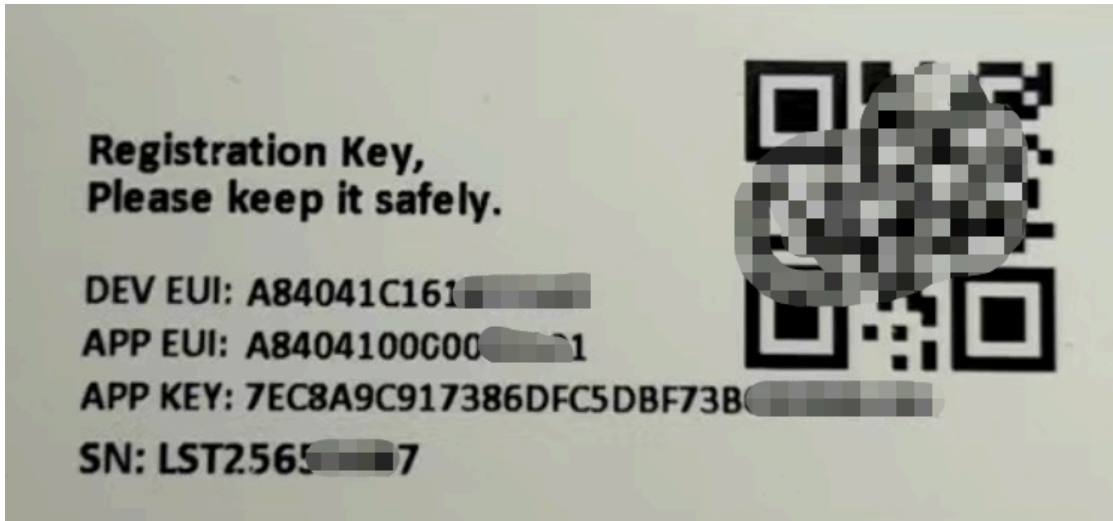

Input these keys to their LoRaWAN Server portal. Below is TTN V3 screen shot:

Add APP EUI in the application:

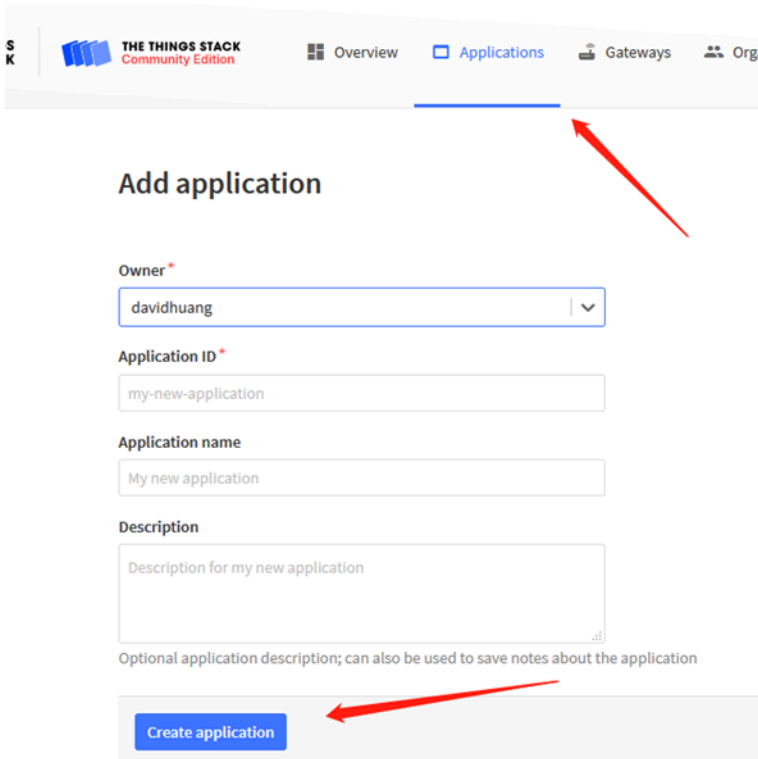

The screenshot shows the TTN V3 'Add application' form. The top navigation bar includes 'Overview', 'Applications', 'Gateways', and 'Orgs'. The 'Applications' menu item is highlighted with a red arrow. The form fields are: 'Owner' (davidhuang), 'Application ID' (my-new-application), 'Application name' (My new application), and 'Description' (Description for my new application). A 'Create application' button is located at the bottom of the form, also highlighted with a red arrow.

The screenshot shows the user interface for a LoRaWAN Tracker. At the top left, there is a logo for 'CCC' with ID: 123. Below it, there are statistics: 4 End devices, 2 Collaborators, and 2 API keys. A timestamp 'Created 95 days ago' is on the right. The main content is divided into two sections: 'General information' and 'Live data'. 'General information' includes fields for Application ID (123), Created at (Feb 2, 2021 11:12:30), and Last updated at (Apr 30, 2021 11:00:33). 'Live data' shows a list of events with timestamps and descriptions like 'Forward data message to Application Server', 'Store upstream data message', etc. At the bottom, there is a table header for 'End devices (4)' with columns for ID, Name, DevEUI, JoinEUI, and Created. A red arrow points to the '+ Add end device' button in the bottom right corner.

The screenshot shows the 'Register end device' form. It has a title 'Register end device' and a sub-section 'From The LoRaWAN Device Repository' with a 'Manually' tab selected. Under 'Preparation', there are radio buttons for 'Activation mode': 'Over the air activation (OTAA)' (selected), 'Activation by personalization (ABP)', 'Multicast', and 'Do not configure activation'. Below that is a 'LoRaWAN version' dropdown menu with 'Select...' and a downward arrow. There are two text input fields: 'Network Server address' and 'Application Server address', both containing 'eu1.cloud.thethings.network'. At the bottom, there is a label 'External Join Server' with a help icon.

Add APP KEY and DEV EUI:

Step 2: Push this button will activate this device.

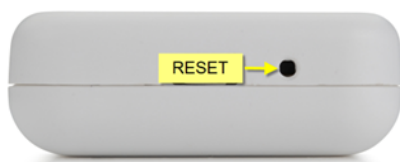

Step 3: TrackerD will auto join to the LoRaWAN network. After join success, TrackerD will start to upload message to IoT server.

2.3 Positioning Mode(SMOD)

Users can set TrackerD to different Positioning Mode for different applications. Below mod are supported.

- **GPS ONLY(Factory Settings):** Only get and uplink GPS location info.
- **BLE or WiFi ONLY:** Only obtain iBeacon info via BLE and uplink or obtain wifi ssid info via WiFi and uplink. Design for Indoor tracking.
- **GPS/BLE Hybrid:** Combination for Indoor and Outdoor tracking. Devices will try to search BLE iBeacon first. If device can't find the iBeacon, it will use GPS for positioning.

Users can switch modes by [changing SMOD](#).

2.4 Uplink Payload

2.4.1 Uplink FPORT=5, Device Status

Uplink the device configures with **FPORT=5**. Once TrackerD Joined the network, it will uplink this message to the server. After the first uplink, TrackerD will uplink Device Status every 12 hours.

Use can also get the Device Status uplink through the downlink command: **Downlink: 0x2301**

Size(bytes)	1	2	1	1	2	1	1
Value	Sensor Model	Firmware Version	Frequency Band	Sub-band	BAT	SMOD	Status

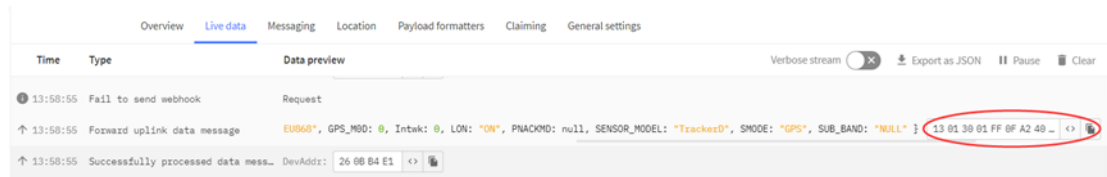

Example of Device Status: 13014001FF0FA24002

Sensor Model: For TrackerD, this value is 0x13

Firmware Version: 0x0140, Means: v1.4.0 version

Frequency Band:

0x01: EU868

0x02: US915

0x03: IN865

0x04: AU915

0x05: KZ865

0x06: RU864

0x07: AS923

0x08: AS923-1

0x09: AS923-2

0x0a: AS923-3

Sub-Band: value 0x00~0x08(only forAU915,US915,Others are 0xFF)

BAT: shows the battery voltage for TrackerD.

Ex1: 0x0FA2 = 4002mV

Use can also get the Device Status uplink through the downlink command:

SMOD Field (total 1 byte): 0x40

Size(bit)	1 bit	2 bits	4 bits
Value	SMOD	GPS_Settings	BLE_Settings

SMOD:

- 1 :** GPS ONLY
- 2 :** BLE ONLY
- 3 :** GPS/BLE Hybrid

GPS_MOD: Define how to send GPS payload

- 0 :** Enable uploading on-board Temperature and humidity values
- 1 :** Disable uploading on-board Temperature and humidity values

BLE_Settings:

- 1:** BLE Positioning with Strongest iBeacon
- 2:** WiFi Positioning with Strongest WiFi SSID(V1.4.1 Version support this function later)

Status Field (total 1 byte): 0x02

Size(bit)	5 Bits	1 Bit	1 Bit	1 Bit
Value	Reserve	PNACKMD	LON	Transport Mode

2.4.2 Uplink FPORT=2, Realtime GNSS Positioning + Temperature & Humidity

Users can use **AT+SMOD=1,0,0** to enable uploading on-board Temperature and humidity values, and the total payload will be 15 bytes,

Size(bytes)	4	4	2	1	2	2
Value	Latitude	Longitude	Alarm & BAT	FLAG	Hum	Tem

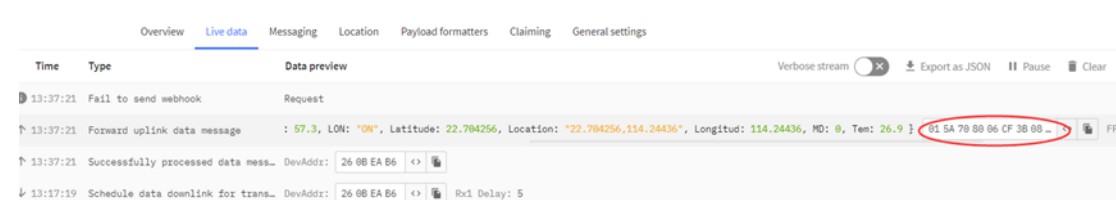

Alarm & BAT:

Size(bit)	1 bit	1 bit	14 bits
Value	reserve	Alarm Indicate	BAT

FLAG:

Size(bit)	2 bits	1 bit
Value	MOD	LON

Example: Payload: 0x02863D68 FAC29BAF 4B45 60 0202 011A

Location info:

- Latitude: 02863D68 ⇒ if (0x02863D68 & 0x80000000 = 0): value = 02863D68 /1000000 = 42.351976
- Longitude: FAC29BAF ⇒ if (0xFAC29BAF & 0x80000000 = 1): value = (0xFAC29BAF – 0x10000000)/1000000 =-87.909457

Important note:

1. When power is low (<2.84v), GPS won't be able to get location info and GPS feature will be disabled and the location field will be filled with 0x0FFFFFFF, 0x0FFFFFFF.
2. In this mode, the total payload will be 15 bytes, while US915/AU915 DR0 accepts only 11 bytes payload. In this case, the payload on server will be ignore and shows as below:



3. While GPS can't get location info after timeout(FTIME Parameter), the latitude and longitude will be filled with all 0x00:

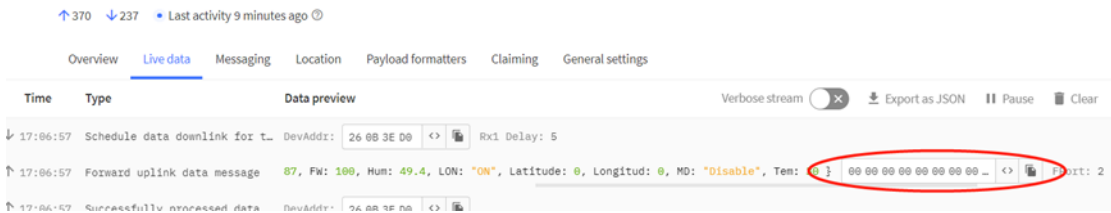

Alarm:

Example: 0x4B & 0x40 >> 6 = 0x01

BAT:

Example: 0x4B45 & 0x3FFF ⇒ 2885 (mV).

The battery info shows the battery voltage, User can use the below mapping to indicate the battery in percentage: \

- > 4.0v : 80% ~ 100%
- 3.85v ~3.99v: 60% ~ 80%
- 3.70v ~ 3.84v: 40% ~ 60%
- 3.40v ~ 3.69v: 20% ~ 40%
- < 3.39v: 0~20%

MOD:

Example: (0x60>>6) & 0x3f =1

Set the format of GPS data uplink link:

- 0x00:** Enable uploading on-board Temperature and humidity values
- 0x01:** Disable uploading on-board Temperature and humidity values

Set the format of BLE data uplink link:

- 0x01:** BLE Positioning with Strongest iBeacon

LON:

Example: (0x60>>5) & 0x01=1.

Enable/Disable LED activity for uplink

- 0x00:** Disable LED indicator.
- 0x01:** Enable LED indicator (Default Value)

Hum:

0230 value = 0x0230 / 10 = 560 ⇒ 56%

Tem:

0202 = if (0x0202 & 0x8000 = 0): value = 0x0202 / 100 = +514 ⇒ 5.14 degree

011A =if (0xF11A & 0x8000 = 1): value =(0xF11A - 0x10000)/100(dec) ⇒ -38.14 degree

2.4.3 Uplink FPORT=3, Realtime GNSS Positioning (Default Mode)

The default uplink payload includes total 11 bytes (**AT+SMOD=1,1,0**). The payload is the first 11 bytes of Uplink FPORT=2, real-time GNSS positioning, (remove the temp and humidity)

Size(bytes)	4	4	2	1
Value	Latitude	Longitude	Alarm & BAT	FLAG



2.4.4 Uplink FPORT=4, History GNSS Positioning

Set **PNACKMD=1**, and TrackerD will wait for ACK for every uplink, when there is no LoRaWAN network, TrackerD will mark these records with non-ack messages and store the sensor data, and it will send all messages (10s interval) after the network recovery.

Note for this mode:

- a) TrackerD will do an ACK check for data records sending to make sure every data arrive server.
- b) TrackerD will send data in CONFIRMED Mode when PNACKMD=1 and CFM=1, but TrackerD won't retransmit the packet if it doesn't get ACK, it will just mark it as a NONE-ACK message. In a future uplink, if TrackerD gets an ACK, TrackerD will consider there is a network connection and resend all NONE-ACK Messages.

- c) the total payload will be 15 bytes, while US915/AU915 DR0 accepts only 11 bytes of payload. In this case (DR0 of US915/AU915), the payload on server will show NULL
- d) The location time is in **GMT(UTC+0)**.

The payload is 15 bytes, as below.

Size(bytes)	4	4	2	1	1	1	1	1
Value	Latitude	Longitude	Year	Month	Day	Hous	Min	Sen



2.4.5 Uplink FPORT=6, BLE Positioning with Strongest iBeacon

TrackerD supports BLE scans for indoor positioning. User can set **SMOD** to **BLE pure** or **GPS/BLE hybrid** so TrackerD will scan BLE iBeacon and find the strongest iBeacon info and uplink.

User can set **BLEMASK** so TrackerD will only search the iBeacons which have UUID that match the BLEMASK settings.

Size(bytes)	16	2	2	1	1	2	1	1	1
Value	UUID	iBeacon MAJOR	iBeacon MINOR	senseless	RSSI of the device within 1m	iBeacon Measured Power	iBeacon RSSI	Alarm & BAT	FLAG



- **BAT:** Ex1:0x4B45 & 0x3FFF ⇒ 3901 (mV).
- **MODE:** Define the payload format.
- **UUID:** The uuid from the strongest iBeacon.
- **MAJOR:** The MAJOR from the strongest iBeacon.
- **MINOR:** The MINOR from the strongest iBeacon.
- **Measured Power:** The Measured Power from the strongest iBeacon.
- **RSSI:** The RSSI from the strongest iBeacon.
- **RSSI_1M:** RSSI of the device within 1m.

2.4.6 Uplink FPORT=7, Alarm information status (Since firmware 1.4.4)

The upward link device is configured to FPORT = 7. Once Trackerd alarm, it will upload the news to the server.

Size(bytes)	2	1
Value	Alarm & BAT	Mod+lon



```
alarm=(bytes[0] & 0x40) // Alarm status
batV=(((bytes[0] & 0x3f) <<8) | bytes[1])/1000; // Battery,units:V
mod = bytes[2] & 0xC0;
Lon=(bytes[2] & 0x20)
```

2.4.7 Uplink FPORT=8, WiFi Positioning with Strongest WiFi SSID (Since firmware 1.4.1)

TrackerD supports WiFi scans for indoor positioning. User can set **SMOD** to **WiFi** so TrackerD will scan WiFi and find the strongest WiFi info and uplink.

Size(bytes)	6	4	2	1
Value	SSID	RSSI	Alarm & BAT	FLAG

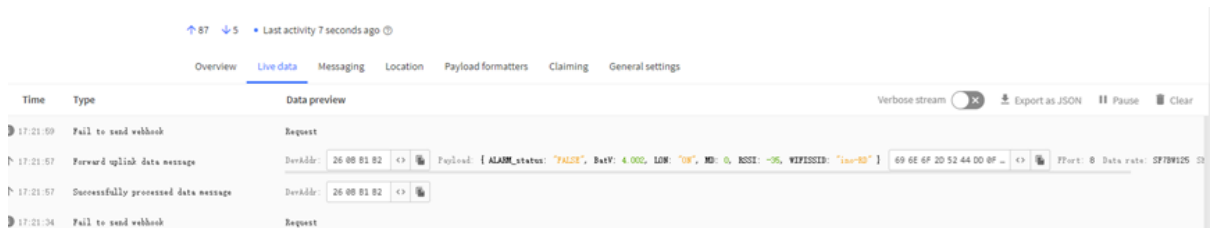

- **BAT:** Ex1:0x4B45 & 0x3FFF ⇒ 3901 (mV).
- **SSID:** WiFi name.
- **RSSI:** The RSSI from the strongest WiFi.

2.4.8 Uplink FPORT=9, BLE Positioning with Multiple iBeacon(Since firmware 1.4.7)

TrackerD supports BLE scanning for indoor positioning. Users can set SMOD to BLE pure or GPS/BLE Hybrid, so TrackerD will scan up to 40 BLE iBeacons and send uplinks.

User can set **BLEMASK** so TrackerD will only search the iBeacons which have UUID that match the BLEMASK settings.

Size(bytes)	2	1	2	2	1	2	2	1	...
Value	Alarm & BAT	FLAG	iBeacon MAJOR	iBeacon MINOR	iBeacon RSSI	iBeacon MAJOR	iBeacon MINOR	iBeacon RSSI	...

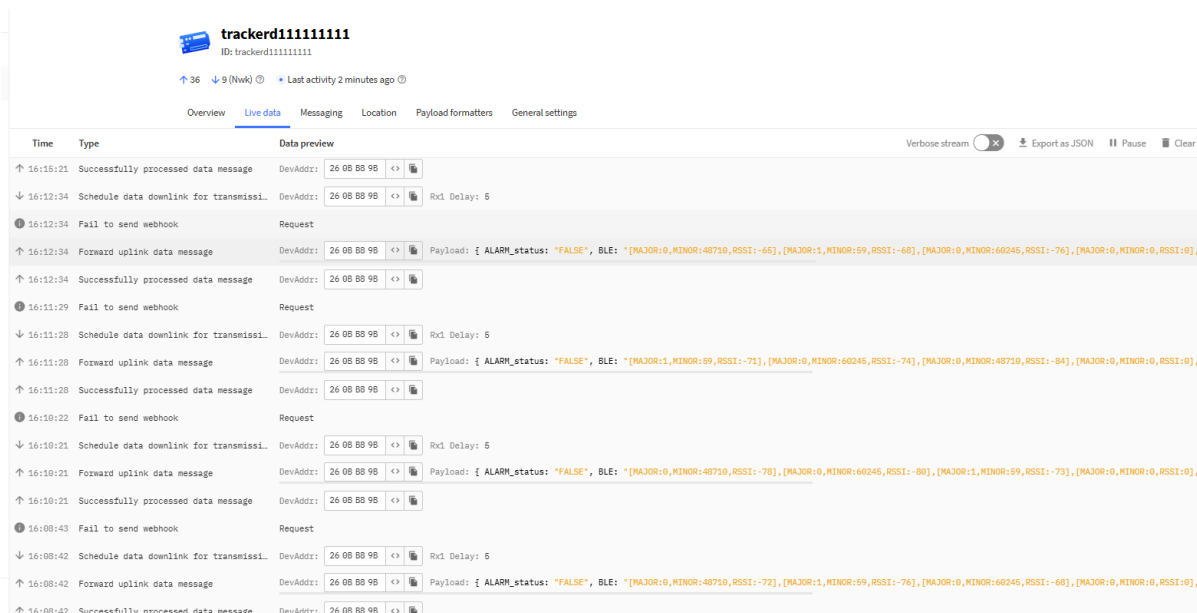

- **BAT:** Ex1:0x4B45 & 0x3FFF ⇒ 3901 (mV).
- **MAJOR:** The MAJOR from the strongest iBeacon.
- **MINOR:** The MINOR from the strongest iBeacon.
- **RSSI:** The RSSI from the strongest iBeacon.
- **MOD:** Bluetooth mode: 1: Search the beacon with the strongest signal. 2: Search the three beacons with the strongest signal. 3: Search all Bluetooth beacons (up to 40 Bluetooth beacons are displayed).

Note: This mode does not have a fixed decoder. Its decoder depends on the number of beacons and can be parsed according to the order of the payload.

payload format: BAT+State+(Major + Minor+Rssi)+(Major + Minor+Rssi)+...(Maximum forty group)...

2.4.9 Add Payload format in TTN V3

In TTN V3, user can add a custom payload so it shows friendly.

In the page [Applications --> Payload Formats --> Custom --> decoder](#)

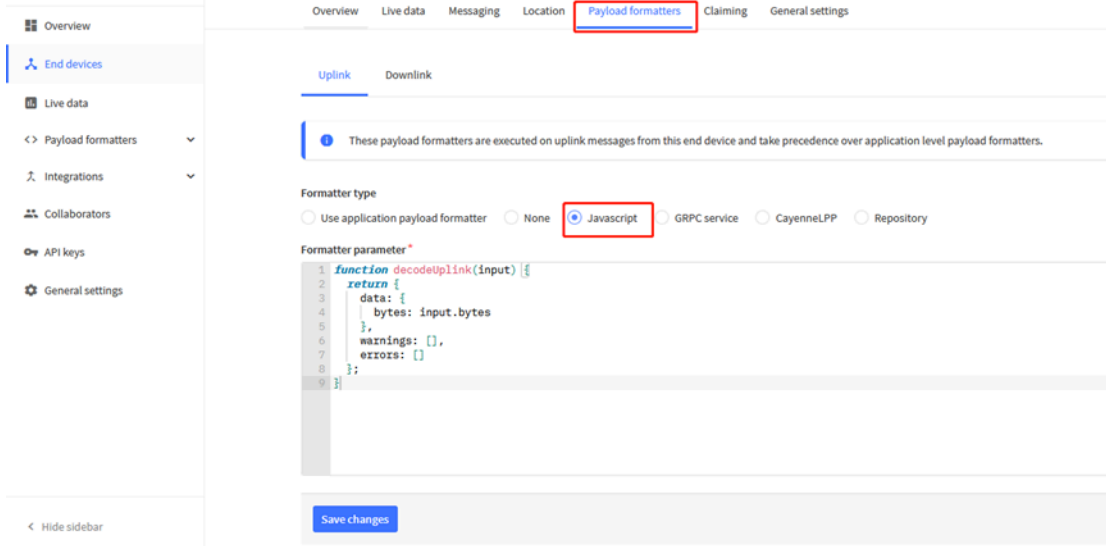

Add the decoder from this link: <https://github.com/dragino/dragino-end-node-decoder/tree/main/TrackerD>

Save the change the uplink message will be parsed. As below:

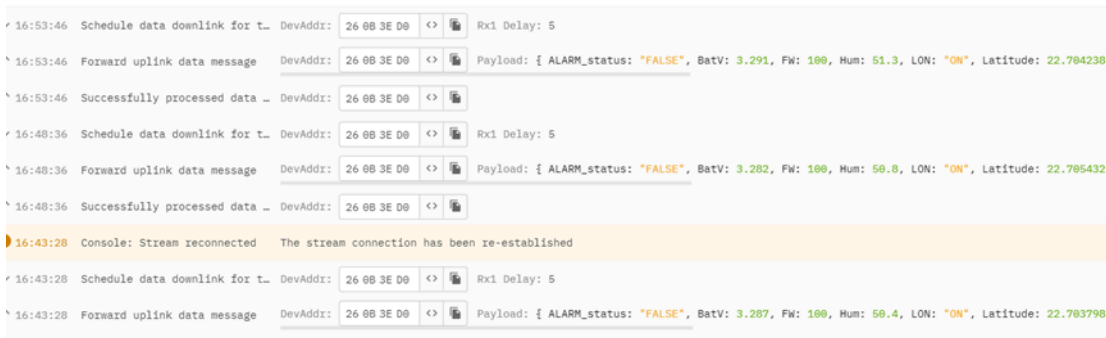

2.5 Integrate with Datacake

After TrackerD sends data to LoRaWAN server such as TTN, use can pass the data to Datacake and plot out, currently only support GPS plot.

Instruction is here: <http://wiki.dragino.com/xwiki/bin/view/Main/Notes%20for%20Data%20Cake/#H7.Example--AddTrackerDGPSTrackingInDataCake>

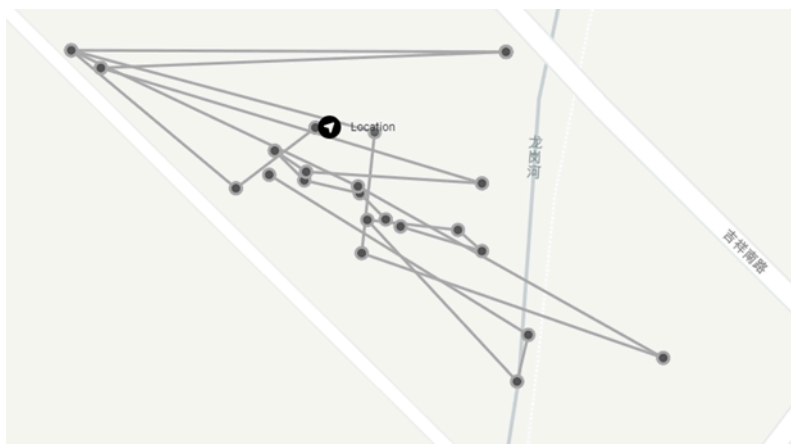

2.6 Integrate with Tago

After TrackerD sends data to LoRaWAN server such as TTN, user can pass the data to Datalog and plot out, currently only support GPS plot.

Instruction is here: <http://wiki.dragino.com/xwiki/bin/view/Main/Tago.IO/#H3.A0Example-CreateTrackerD2FLGT92positioningwidget>

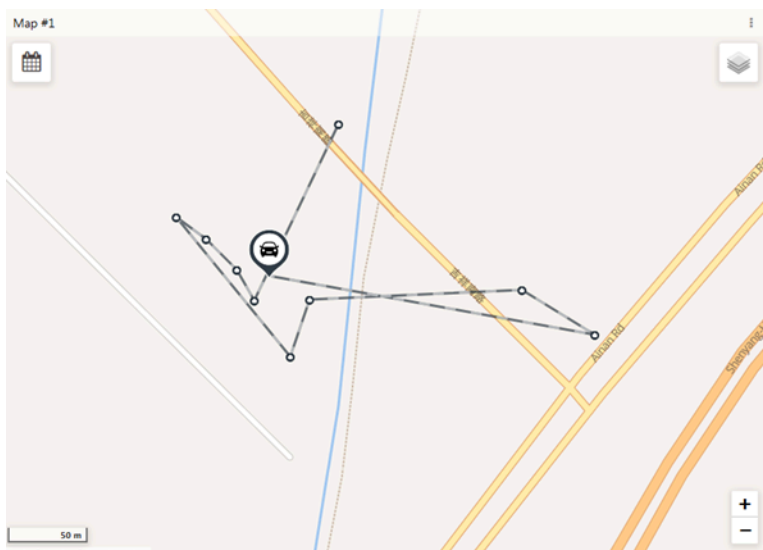

2.7 Integrate with Node-red

1. Install node-red, please refer to the installation method in the link:

<http://wiki.dragino.com/xwiki/bin/view/Main/Node-RED/#H1.A0Installation>

2. Import the created flow template, please refer to the import method in the link:

<http://wiki.dragino.com/xwiki/bin/view/Main/Node-RED/#H3.A0Importsampleflow>

The address of the flow template: [dragino-end-node-decoder/TrackerD.json at main · dragino/dragino-end-node-decoder · GitHub](https://github.com/dragino-end-node-decoder/TrackerD.json)

Note: If you are using NODE-RED for the first time, please search and install the two plug-ins in the figure below in node-red to fully use the flow template.

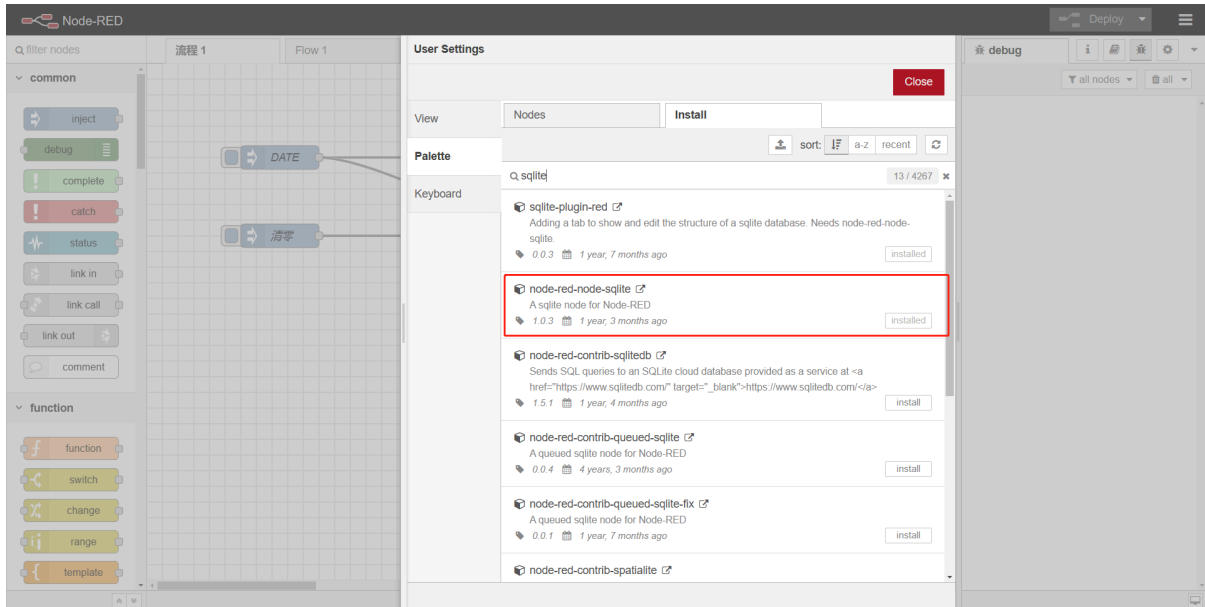

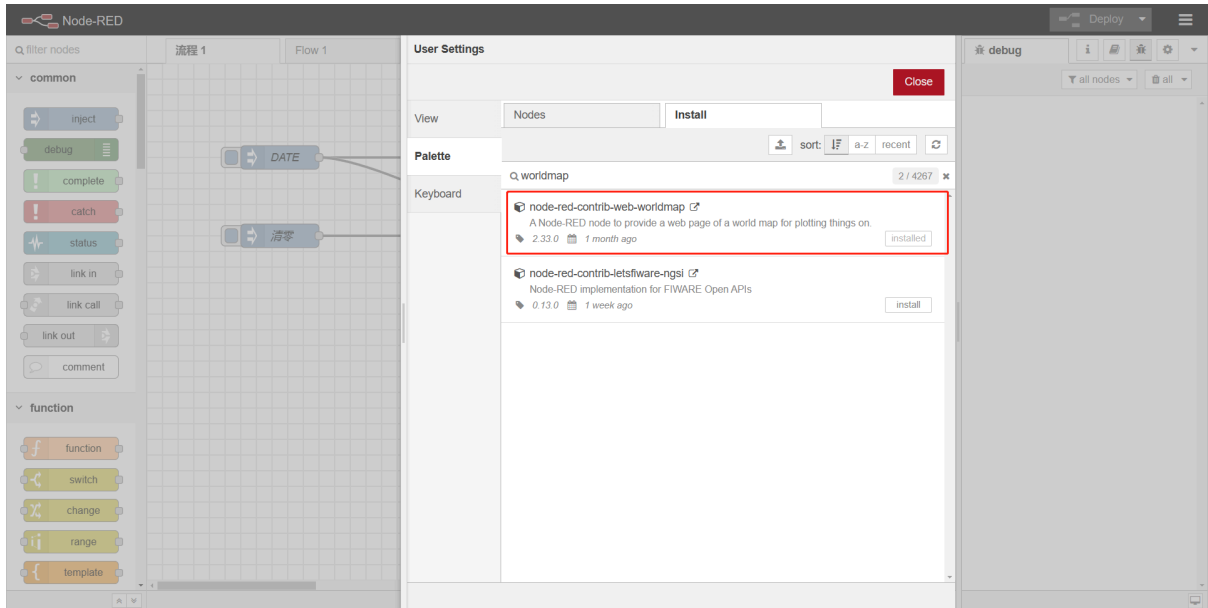

3. Display the map

Enter the link to the map:

Change its suffix to `ditu`: <http://119.91.62.30:1880/ditu/>

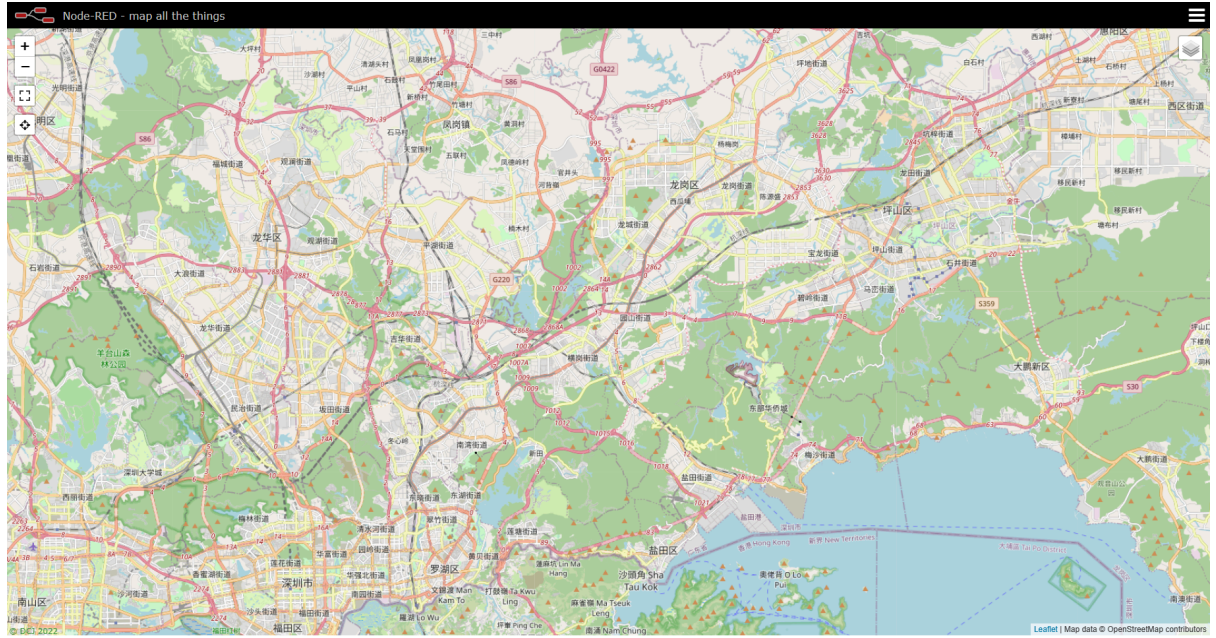

Hit all input in input stream

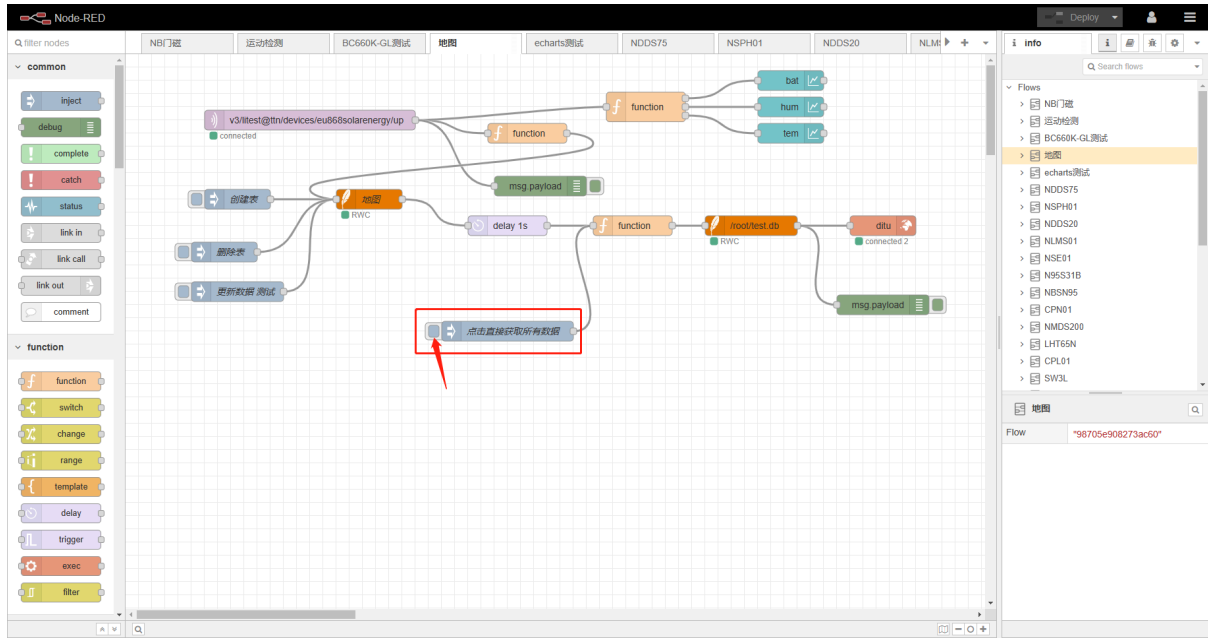

View map again

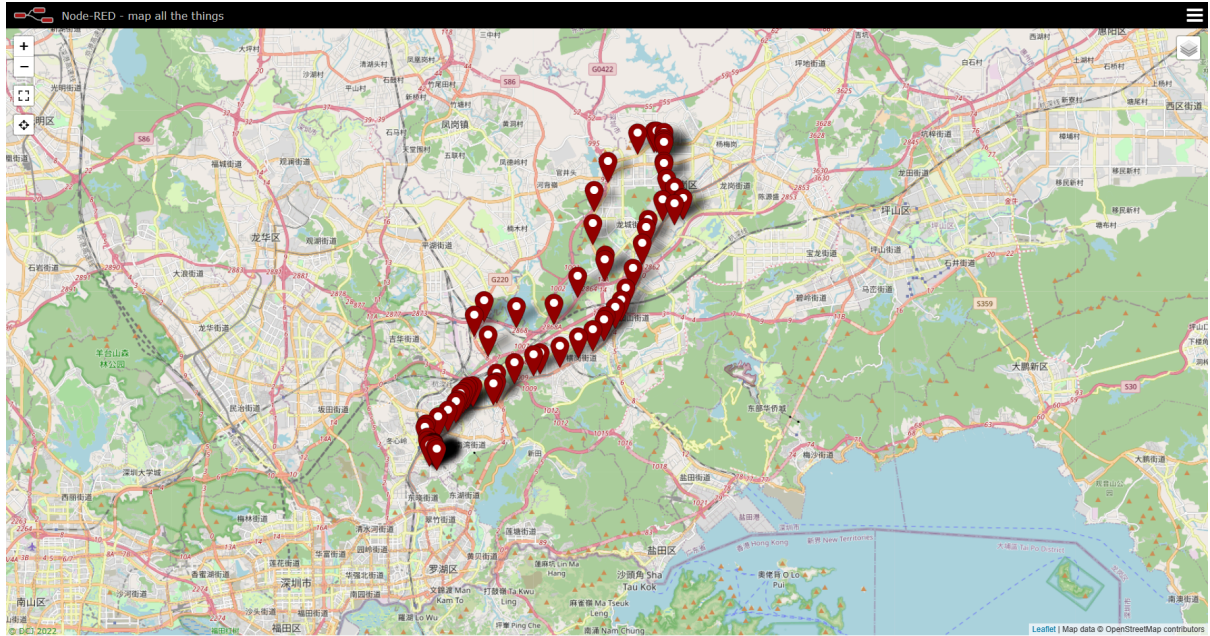

2.8 Datalog Feature

total 273 entries,by default,

User can set [PNACKMD=1](#), to enable Datalog feature.

Example use case.

TrackerD used in fleet management

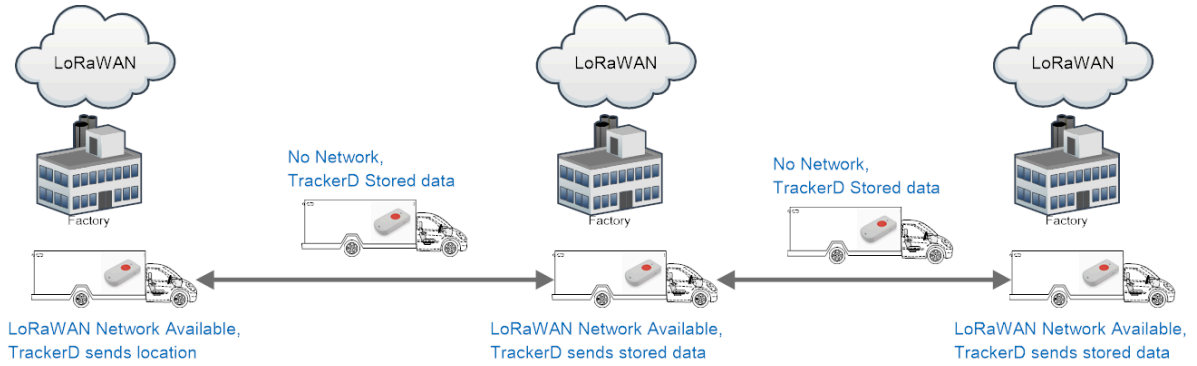

TrackerD to track excursion

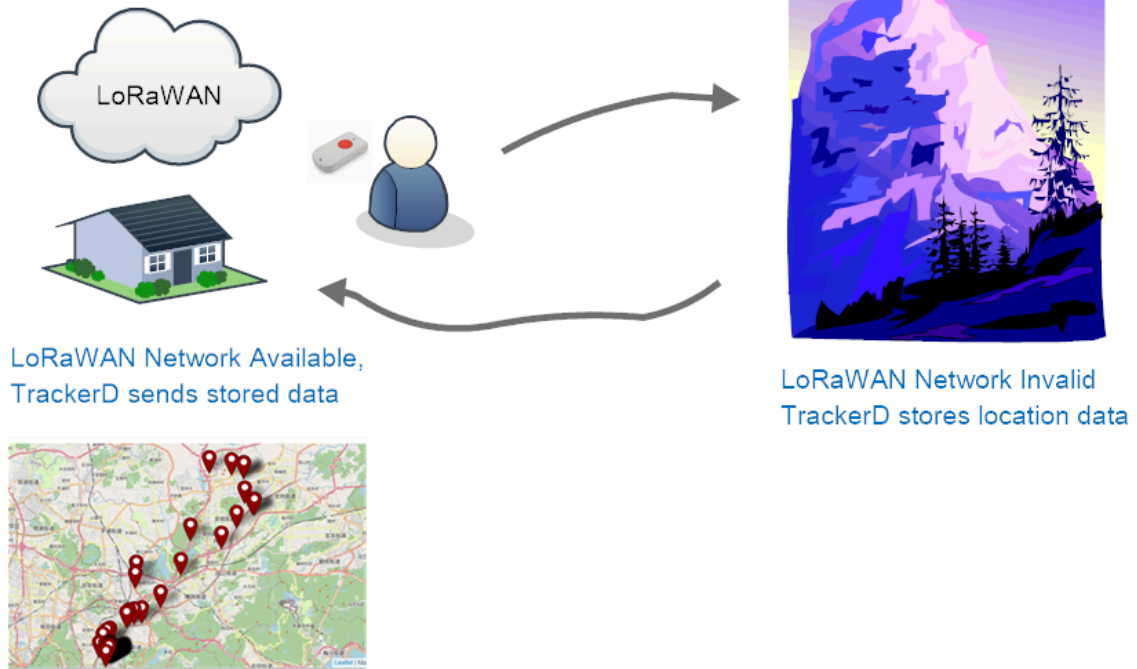

2.9 Alarm Mode

User can push the **RED button** by more than 5 seconds to enter Alarm Mode. Alarm Mode is used to send SOS info to IoT platform.

Once enter Alarm mode, the **GREEN LED** will flash 3 times, the buzzer will alarm for 5 seconds, then TrackerD will immediately send a packet without location info and then send a data packet with GPS positioning information. After that, the device will send 60 packets at 1-minute intervals. The Alarm flag in the payload will be set for the next 60 packets unless exits alert mode.

Two ways to exit alarm mode:

- Server sends a downlink command to exit.
- User fast press the RED button 10 times.

When exit alarm mode, **RED LED** will light up for 5 seconds, indicating that the alarm mode is exited. And the alert flag will be set to false.

2.10 Transport Mode

In Transport Mode, TrackerD will check if there is motion (threshold defined by **PT**) . If there is no motion, device will send uplinks every 20 minutes (Defined by **TDC**) . If there is motion, device will send uplink every 5 minutes(defined by **MTDC**).

When device is set in Transport Mode, it will uplink more frequently during moving.

- **MTDC** defines the Uplink Interval during transportation.
- **TDC** defines the uplink interval when TrackerD is stactic.
- **PT** defines the threldhold to detect a motion.

2.11 LED Status

Event	Action	AT+LON to control on/off
Power On	BLUE, RED , Green flash once	N/A
Join request	Green led fast blink once (200ms)	Yes
Join Success	Green led on 5 second	N/A
Fixing Location	BLUE blinks 200ms per second	Yes
Fixed and uplink	GREEN blinks twice (200ms per blink)	Yes
Fail Fix and uplink	RED blinks twice (200ms per blink)	Yes
Enter Alarm mode	RED on for 3 seconds	Yes
Uplink under Alarm	RED on for 1 second	Yes
Exit Alarm	BLUE led on 5 second	Yes
Get Downlink	GREEN led on 1 second	Yes
Movement Detect	RED led on 500ms	N/A

2.12 Button Function

RESET button:

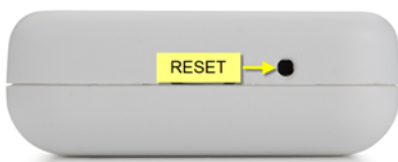

Push this button will reboot the device. Device will exit alarm mode and re-join to LoRaWAN server.

RED button:



Function	Action	Description
Send Alarm	Keep Pressing RED button for more than 5 seconds	Enter Alarm Mode. See Alarm Mode
Exit Alarm Mode	Fast press the RED button 10 times	Exit Alarm Mode
Enter Deep Sleep Mode	Press and hold the button for 10 seconds, then quickly press the device 3 times to enter deep sleep	This is the mode ship out from factory. CPU will be complete in sleep mode and no LoRa activity, only use before deploy.

2.13 USB Port Function

The USB interface of TrackerD has below functions:

- Power on the device
- Recharge the battery
- [Configure Device](#)
- [Upgrade Firmware](#)

2.14 Sleep Mode

Sleep Mode: To prevent accidental touch of the red button during transportation or assembly, so the peripherals of the device are turned off and enter deep sleep.

In SLEEP mode, you need to reset by **reset button**.

Use the **AT+SLEEP** command to put the device into sleep.

3. Configure TrackerD via AT command or LoRaWAN downlink

User can configure TrackerD via AT Command or LoRaWAN Downlink.

LoRaWAN Downlink instruction for different platforms: [IoT LoRaWAN Server](#)

3.1 Access AT Command

TrackerD supports the AT command set in stock firmware. User can connect to TrackerD with TYPE-C cable to use AT commands as shown below.



In PC, User needs to set serial tool baud rate to **115200** to access serial console for TrackerD. TrackerD will output system info once power on and user will be able to send AT commands:

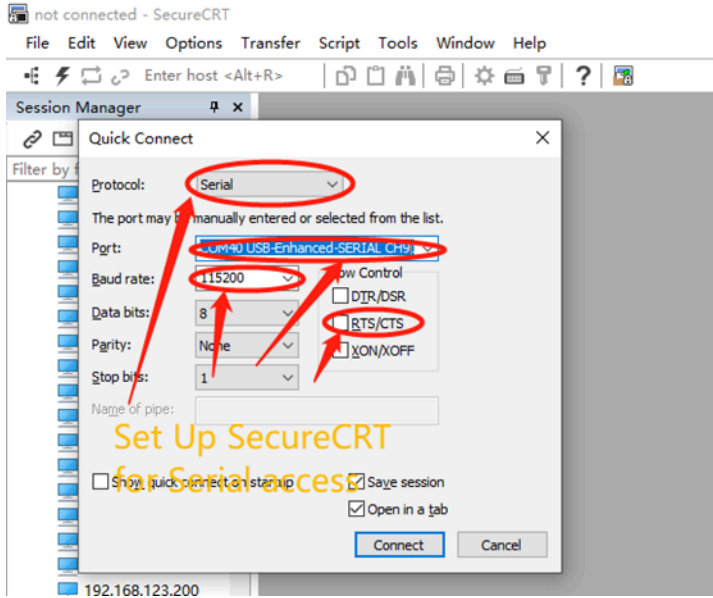

```

rst:0x5 (DEEPSLEEP_RESET),boot:0x13 (SPI_FAST_FLASH_BOOT)
configsip: 188777542, SPIWP:0xee
clk_drv:0x00,q_drv:0x00,d_drv:0x00,cs0_drv:0x00,hd_drv:0x00,wp_drv:0x00
mode:DIO, clock_div:1
load:0x3fff0030,len:1284
load:0x40078000,len:12836
load:0x40080400,len:3032
entry 0x400805ed
wake up caused by timer
TDC=1200000
BAT:4.20 V
Start searching for GPS ..
Latitude = 22.704861
Longitude = 114.245430
Date: 2022-9-17
Time: 10:49:49
HUM:32.42
TEM:37.55
1126654: UpLinkCounter = 1
EV_TXSTART
1132946: TXMODE, freq=868100000, len=30, SF=7, BW=125, CR=4/5, IH=0
Packet queued
start single rx: now-rxtime: 3
1448585: RXMODE_SINGLE, freq=868100000, SF=7, BW=125, CR=4/5, IH=0
rxtimeout: entry: 1451608 rxtime: 1448577 entry-rxtime: 3031 now-entry: 6 rxtime-txend: 311126
start single rx: now-rxtime: 3
1510833: RXMODE_SINGLE, freq=869525000, SF=12, BW=125, CR=4/5, IH=0
rxtimeout: entry: 1527234 rxtime: 1510827 entry-rxtime: 16407 now-entry: 5 rxtime-txend: 373376
1527256: EV_TXCOMPLETE (includes waiting for RX windows)
Enter sleep mode
    
```

3.2 Command Set

3.2.1 Set Transmit Interval

Set device uplink interval.

- **AT Command:**

AT+TDC=xxx

Example: AT+TDC=300000. Means set interval to 5 minutes(300 seconds)

- **Downlink Payload (prefix 0x01):**

0x01 00 01 2C // Same as AT+TDC=300000

3.2.2 Set Alarm Packet transmission interval

Set alarm packet transmit interval

- **AT Command:**

AT+ATDC=xx.

Example: AT+ATDC=60000 --> Set Alarm Packet Interval to 60 seconds. TrackerD will send every 60 seconds in Alarm mode, Default Value: 60000

- **Downlink Payload (prefix 0xB1):**

0xB1 00 00 3C // Same as AT+ATDC=60000

3.2.3 Set Transport Mode Packet transmission interval

Set Transport Mode packet transmit interval

- **AT Command:**

AT+MTDC=xx.

Example: AT+MTDC=300000 --> Set Transport Mode Packet Interval to 300 seconds. TrackerD will send every 300 seconds in Transport mode, Default Value: 300000

- **Downlink Payload (prefix 0x03):**

0x03 00 01 2C // Same as AT+MTDC=300000

3.2.4 Exit Alarm

Server send downlink command to exit Alarm mode

- **AT Command: No AT Command**
- **Downlink Payload (prefix 0x02):**

0x02 01 // Exit Alarm Mode

3.2.5 Disable/Enable LED flash and buzzer

Disable/Enable LED for position, downlink and uplink

- **AT Command:**

AT+LON=xx. (Disable (0), Enable (1), default:1)

Example: AT+LON=0 --> Disable LED for position, downlink and uplink.

- **Downlink Payload (prefix 0xAE):**

0xAE 00 // Same as AT+LON=0

3.2.6 Disable/Enable Transport Mode

Users can use this feature to enable/disable Transport Mode.

- **AT Command:**

AT+INTWK=xx. (Disable (0), Enable (1), default:0)

Example: AT+INTWK=1 --> Enable Transport Mode.

- **Downlink Payload (prefix 0xAF):**

0xAF 01 // Same as AT+INTWK=1

3.2.7 Set Positioning Mode

SMOD define how TrackerD scan and uplink data:

- **AT Command:**

AT+SMOD=aa,bb,cc

aa:

- **1: GPS ONLY(Factory Settings):** Only get and uplink GPS location info.
- **2: BLE or WiFi ONLY:** Only obtain iBeacon info via BLE and uplink or obtain WiFi ssid info via WiFi and uplink. Design for Indoor tracking.
- **3: GPS/BLE Hybrid:** Combination for Indoor and Outdoor tracking.Devices will try to search BLE iBeacon first. If device can't find the iBeacon, it will use GPS for positioning.

bb:

- **0:** GPS+ BAT+ State+Tem&Hum
- **1:** GPS +BAT State

cc:

- **1**: (iBeacon)UUID+ Major + Minor+Power+Rssi+BAT+State
- **2**: (WiFi)SSID+Rssi+BAT+State (V1.4.1 Version support this function later)

Example:

```
AT+SMOD=1,0,0 --> GPS+ BAT+ State+Tem&Hum
AT+SMOD=1,1,0 --> GPS +BAT State
AT+SMOD=2,0,1 --> (iBeacon)UUID+ Major + Minor+Power+Rssi+BAT+State
AT+SMOD=2,0,2 --> (WiFi)SSID+Rssi+BAT+State
AT+SMOD=2,0,3 --> (iBeacon) (Major + Minor+Rssi)+(Major + Minor+Rssi)+...(Maximum forty group)...
+BAT+State
```

- **Downlink Payload (prefix 0xA5):**

```
0xA5 01 00 00 // Same as AT+SMOD=1,0,0
```

3.2.8 Set MAX GPS position time

Set max positioning time, default is 150 seconds. TrackerD will try to get location info within this period. If fail to get position data within this time, TrackerD will use 000000 for latitude and longitude.

If **AT+FTIME=0**. The GPS module will be always powered and positioning. This will highly increase the power consumption (up to 50mA). When **AT+FTIME=0**, it will improve fix accuracy and shorten the acquire time for next uplink.

- **AT Command:**

```
AT+FTIME=xx --> Set to use xx as max fix time.
```

Example: AT+FTIME=150

- **Downlink Payload (prefix 0xAA):**

```
0xAA 00 96 // Set AT+FTIME=150
```

3.2.9 Set PDOP value for GPS fix accuracy

PDOP(Position Dilution of Precision) filter, TrackerD will only accept GPS data with a lower PDOP value than pre-configure PDOP value. If device can't get a valid GPS packet within FTIME timeout, it will use the GPS data with lowest PDOP value to server.

A GPS packet with lower PDOP has higher accuracy. PDOP default value is 2.0

- **AT Command:**

```
AT+PDOP=2.5 --> Set PDOP to 2.5
```

- **Downlink Payload (prefix 0xAD):**

```
0xAD 00 0A // Set AT+PDOP=1 (0x0A / 10 =1)
```

```
0xAD 00 19 // Set AT+PDOP=2.5 (0x19 / 10 =2.5)
```

```
0xAD 00 46 // Set AT+PDOP=7 (0x46 / 10 =7)
```

3.2.10 Disable/Enable the confirmation mode

- **AT Command:**

AT+CFM=xx

Example:

AT+CFM=0 --> Disable confirmation

AT+CFM=1 --> Enable confirmation

- **Downlink Payload (prefix 0x05):**

0x05 01 // Same as AT+CFM=1

3.2.11 Auto Send None-ACK messages

TrackerD will wait for ACK for each uplink, If TrackerD doesn't get ACK from the IoT server, it will consider the message doesn't arrive server and store it. TrackerD keeps sending messages in normal periodically. Once TrackerD gets ACK from a server, it will consider the network is ok and start to send the not-arrive message.

- **AT Command: AT+PNACKMD**

The default factory setting is 0.

Command Example Function Response:

AT+PNACKMD=1 // Poll None-ACK message OK

- **Downlink Command: 0x34**

Example: 0x34 01 // Same as AT+PNACKMD=1

3.2.12 Set BLEMASK to filter BLE iBeacon

BLEMASK is to filter the unwanted BLE iBeacons during scan. For example, if BLEMASK is 123456. TrackerD will only uplink UUID info which includes 123456. It will ignore all other iBeacons which doesn't contact 123456 in the UUID.

Note: BLEMASK range is 6 ~ 10 bytes. If AT+BLEMASK < 6 bytes, BLEMASK will be disabled.

AT Command:

AT+BLEMASK=123456 // Set BLEMASK = 123456

AT+BLEMASK=0 // disable BLEMASK

Downlink Payload: (Prefix : 0xB2)(Since firmware 1.4.1)

Example: 0xB2 01 02 03 04 05 06 // Set BLEMASK to 123456

3.2.13 Set WiFIMASK to filter WiFi SSID(Since firmware 1.4.1)

WiFIMASK is to filter the unwanted WiFi SSID during scan. For example, if WiFIMASK is 123456. TrackerD will only uplink SSID info which includes 123456 as prefix. It will ignore all other WiFi which doesn't contact 123456 in the SSID.

Note: WiFIMASK range is 6 ~ 10 bytes. If AT+ WiFIMASK < 6 bytes, WiFIMASK will be disabled.

AT Command:

AT+WiFIMASK=123456 // Set WiFIMASK = 123456

AT+WiFIMASK=0 // disable WiFIMASK

Downlink Payload: (Prefix : 0xB3)(Since firmware 1.4.1)

Example: 0xB3 01 02 03 04 05 06 // Set WiFiMASK to 123456

3.2.14 Disable/Enable Information printing(Since firmware 1.4.1)

Users can use this feature to enable/disable Information printing.

AT Command:

AT+SHOWID=XX // (Disable (0), Enable (1), default:0)

Example: AT+SHOWID=1 --> Enable Information printing.

3.2.15 Get or Set Eight Channels Mode, only for us915, AU915(Since firmware 1.4.1)

The Channels Mode in the LORAWAN LMIC library is from 0 ~ 7. When CHE = 8, 72 channels will be accessible to the network.

AT Command:

AT+CHE=1 // set one channels mode

Downlink Payload:0X24

Example: 0x24 01 // Same as AT+CHE=1

3.2.16 Get or Set Threshold for motion detect(Since firmware 1.4.3)

User can set the motion detect threshold for transportation mode. The smaller the value, the more sensitivity to trigger a motion event.

AT Command:

AT+PT=xx

Example:

AT+PT=14 --> Set to detect car motion.

AT+PT=41 --> set to detect walk motion.

Downlink Payload:0xB4

0xB4 14 // Same as AT+PT=14

3.2.17 Set AT command window time(Since firmware 1.4.5)

AT command window time setting, customers can set the required time according to their own operation mode. The unit is second.

AT Command:

AT+ATST=XX

Example:

AT+ATST=15 --> Set the time to 15 seconds

Downlink Payload:0XB5

0xB5 0F // Same as AT+ATST=15

3.2.18 Set the stepmeter mode(Since firmware 1.4.5)

After setting the step counting mode, it cannot be interrupted by motion. This mode is very power consuming. Used on some special occasions.

AT Command:

AT+PM=xx

Example:

AT+PM=1 --> Turn on step counting mode

AT+PM=0 --> Turn OFF step counting mode

Downlink Payload:0XB6

0xB6 01 // Same as AT+PM=1

3.2.19 Set down the decline detection mode(Since firmware 1.4.5)

This mode is used in conjunction with AT+PT(The recommended threshold is between 50 and 70, you need to set it according to the environment yourself). This function is used in hospitals, nursing homes, nursing homes and other places to prevent the elderly and patients from falling. No one knows.

AT Command:

AT+FD=xx

Example:

AT+FD=1 --> Turn on the Fall detection

AT+FD=0 --> Turn OFF the Fall detection

Downlink Payload:0XB7

0xB7 01 // Same as AT+FD=1

3.2.20 Disable/Enable buzzer(Since firmware 1.4.6)

Disable/Enable buzzer for Alarm, downlink and uplink

AT Command:

AT+BEEP=XX

Example:

AT+BEEP=1 --> Turn on the buzzer

AT+BEEP=0 --> Turn OFF the buzzer

Downlink Payload:0XB9

0xB9 01 // Same as AT+BEEP=1

3.2.21 Set long press time(Since firmware 1.4.6)

When using the red button Changan to alarm, press and hold the time to set 0~10 seconds(The default value is 5 seconds), which is convenient for use scenarios.

AT Command:

AT+EAT=XX

Example:

AT+EAT=2 --> Set the long press time to 2s

Downlink Payload: 0XBA

0xBA 02 // Same as AT+EAT=2

3.2.22 Set the Bluetooth scan time(Since firmware 1.5.1)

Use this command to set the Bluetooth scan time. Default is 5s, value range: 1~255.

AT Command:

AT+BTDC=XX

Example:

AT+BTDC=5 --> Set the Bluetooth scan time to 5s

Downlink Payload:

No downlink

3.2.23 Conversion of TrackerD and TrackerD-LS(Since firmware 1.4.9)

They use the same source code and can be converted using the AT command below

AT Command:

AT+DEVICE=22

Example:

AT+DEVICE=22 --> Set to TrackerD-LS

AT+DEVICE=13 --> Set to TrackerD

4. Setting for Different Scenarios

5. Upload Firmware

5.1 Firmware Change Log

[See this link](#)

5.2 How to upgrade firmware

User can use the TrackerD's USB port to upgrade firmware into it. The hardware connection for upgrade firmware is as below:

Step1: Connect TrackerD and PC via USB cable shipped with TrackerD.

Step2: Install CH9102 driver in the PC.

After installation of the driver and plug in TrackerD, user should be able to see com port in PC's device manager.

Step3: Download and Install Flash Tool: [Tools | Espressif Systems](#)

Step4: Run Flash Download Tool and configure chip type to ESP32

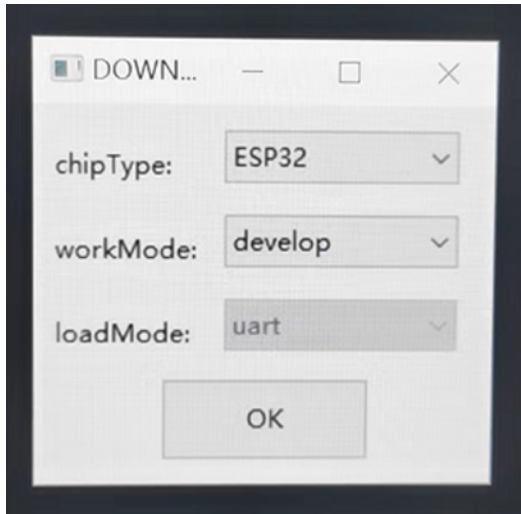

Step5: Select the firmware file (.bin format), com port and proper SPI configure. Click Start. Bin file location:

<https://github.com/dragino/TrackerD/releases>

Users need to use below files:

boot_app0.bin @0e000

US915.bin @ 0x10000(Select the bin file of the frequency band you need)

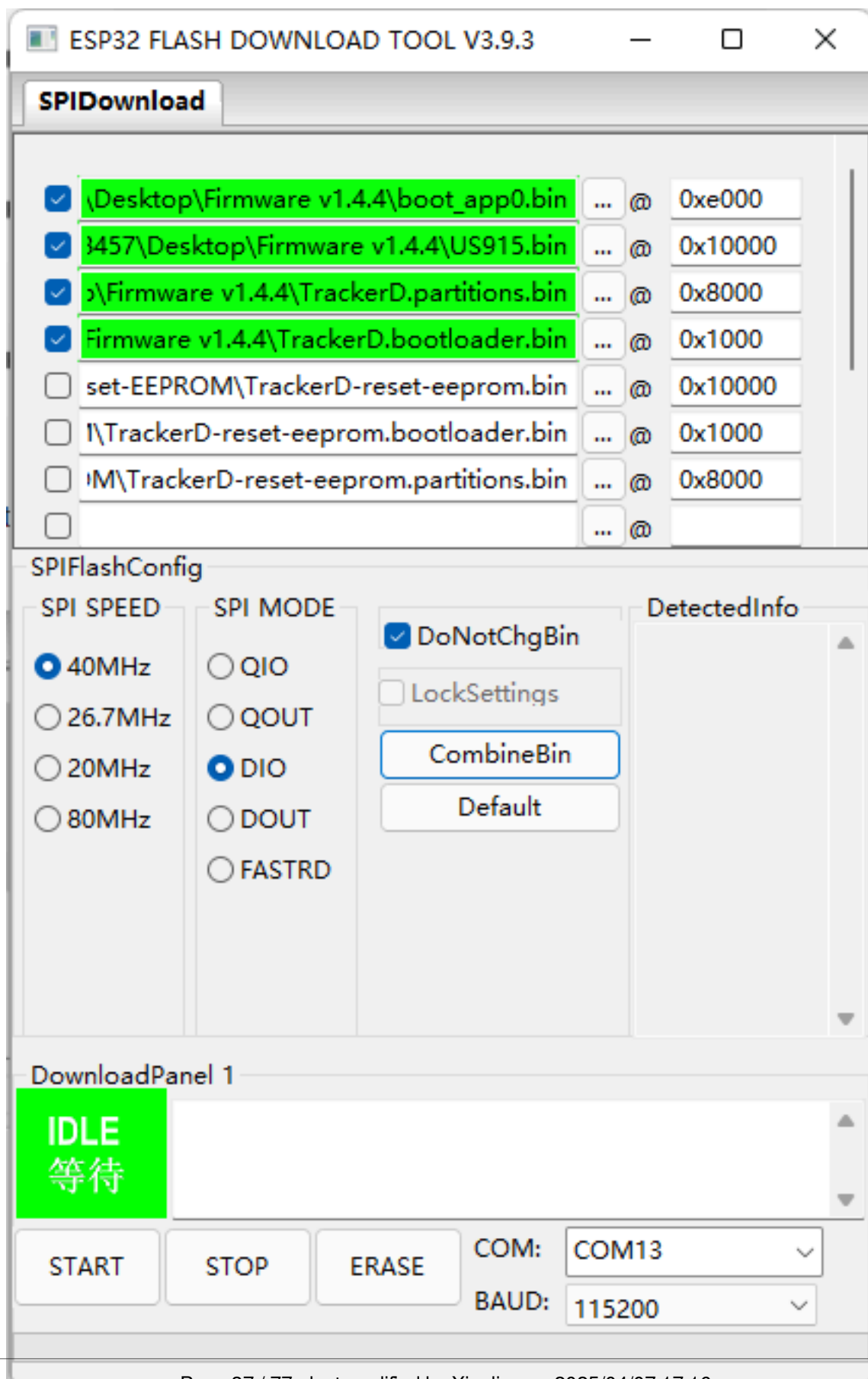

After upgrade finish, it will show finish as below:

The screenshot displays the SPI Download software interface. At the top, the 'SPIDownload' tab is active. Below it is a list of files to be downloaded, each with a checkbox, a file path, a size, and a starting address. The first four files are selected and highlighted in green. Below the file list is the 'SPIFlashConfig' section, which includes settings for SPI Speed (40MHz selected), SPI Mode (DIO selected), and checkboxes for 'DoNotChgBin' (checked) and 'LockSettings' (unchecked). There are also 'CombineBin' and 'Default' buttons. To the right of these settings is the 'DetectedInfo' section, which shows detected hardware information: flash vendor: C8h : GD, flash devID: 4016h, QUAD;32Mbit, and crystal: 40 Mhz. At the bottom, there is a 'DownloadPanel 1' section with a large blue 'FINISH' button (with '完成' below it) and a text area showing AP: 4C752596ECE1, STA: 4C752596ECE0, BT: 4C752596ECE2, and ETHERNET: 4C752596ECE3. Below this are buttons for 'START', 'STOP', and 'ERASE', along with dropdown menus for 'COM:' (COM13) and 'BAUD:' (115200).

File Path	Size	Address
are.v1.4.4\Firmware v1.4.4\boot_app0.bin	...	0xe000
rmware.v1.4.4\Firmware v1.4.4\US915.bin	...	0x10000
4\Firmware v1.4.4\TrackerD.partitions.bin	...	0x8000
Firmware v1.4.4\TrackerD.bootloader.bin	...	0x1000
C:\Users\18457\Desktop\Reset-EEPROM\...	...	0x10000
C:\Users\18457\Desktop\Reset-EEPROM\...	...	0x1000
C:\Users\18457\Desktop\Reset-EEPROM\...	...	0x8000

SPIFlashConfig

SPI SPEED: 40MHz, 26.7MHz, 20MHz, 80MHz

SPI MODE: QIO, QOUT, DIO, DOUT, FASTRD

DoNotChgBin, LockSettings

Buttons: CombineBin, Default

DetectedInfo

flash vendor: C8h : GD
flash devID: 4016h
QUAD;32Mbit
crystal: 40 Mhz

DownloadPanel 1

FINISH
完成

AP: 4C752596ECE1 STA: 4C752596ECE0
BT: 4C752596ECE2 ETHERNET: 4C752596ECE3

START STOP ERASE

COM: COM13
BAUD: 115200

6. Developer Guide

6.1 Compile Source Code

6.1.1 Set up ARDUINO compile environment

- Download the latest Arduino software (IDE) from the Arduino official website: <https://www.arduino.cc/en/Main/Software>

Install IDE on PC, open and click **File --> Preference**, add the following URL: https://dl.espressif.com/dl/package_esp32_index.json

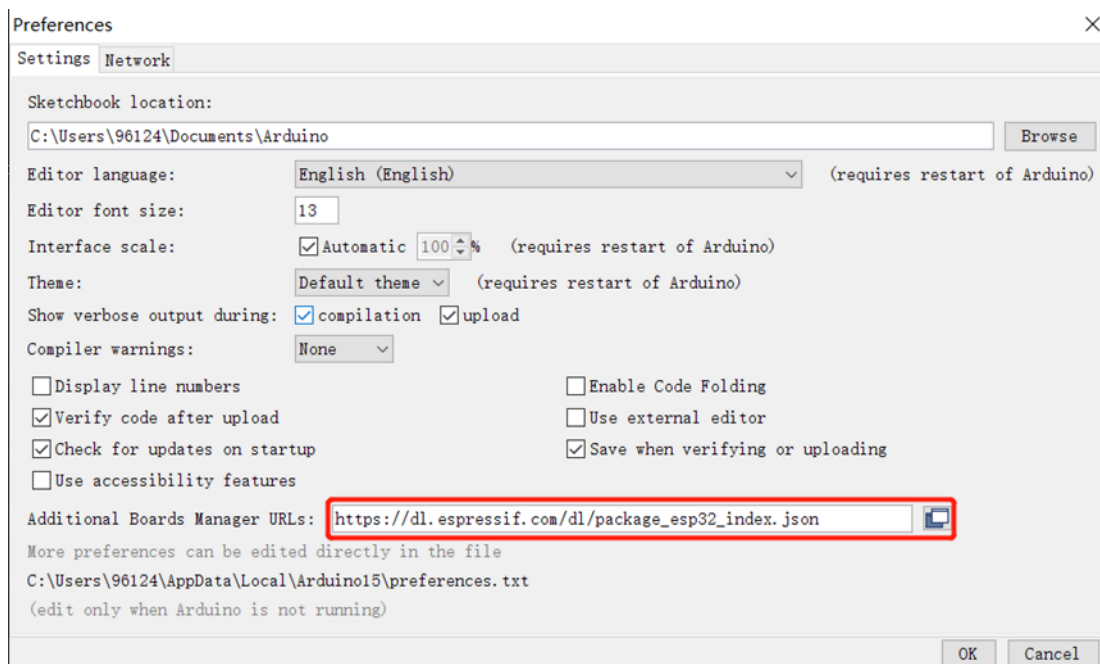

- Go to **tools --> Boards --> Boards Manager**, find the esp32 information and install it.

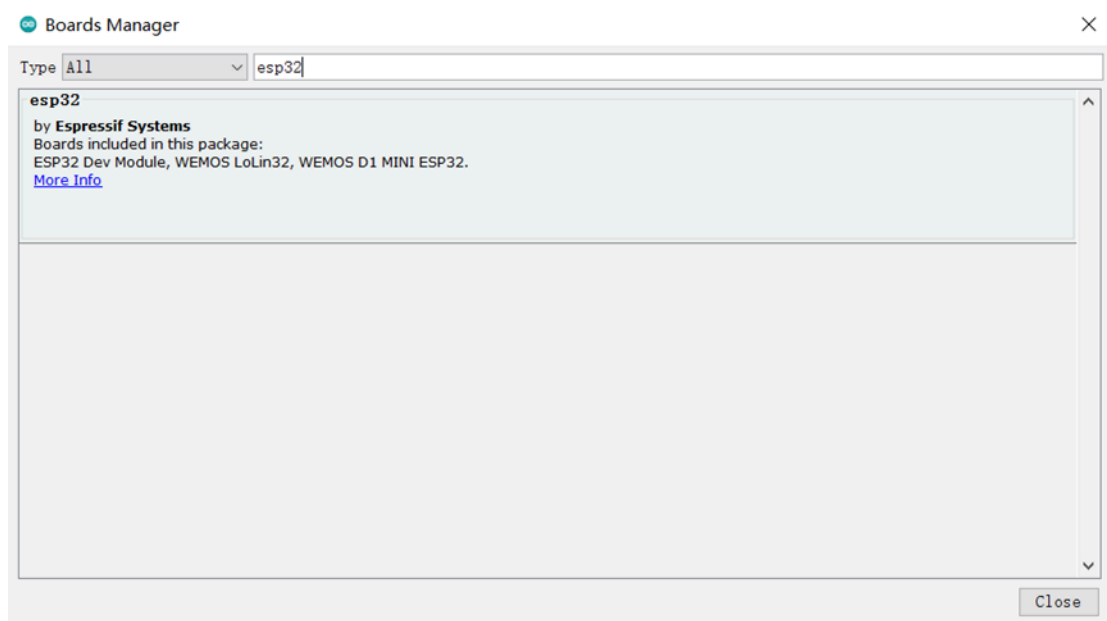

6.1.2 Build the development environment

1. Download and install arduino IDE

<https://www.arduino.cn/thread-5838-1-1.html>

2. Download the ESP32 development package in the arduino IDE

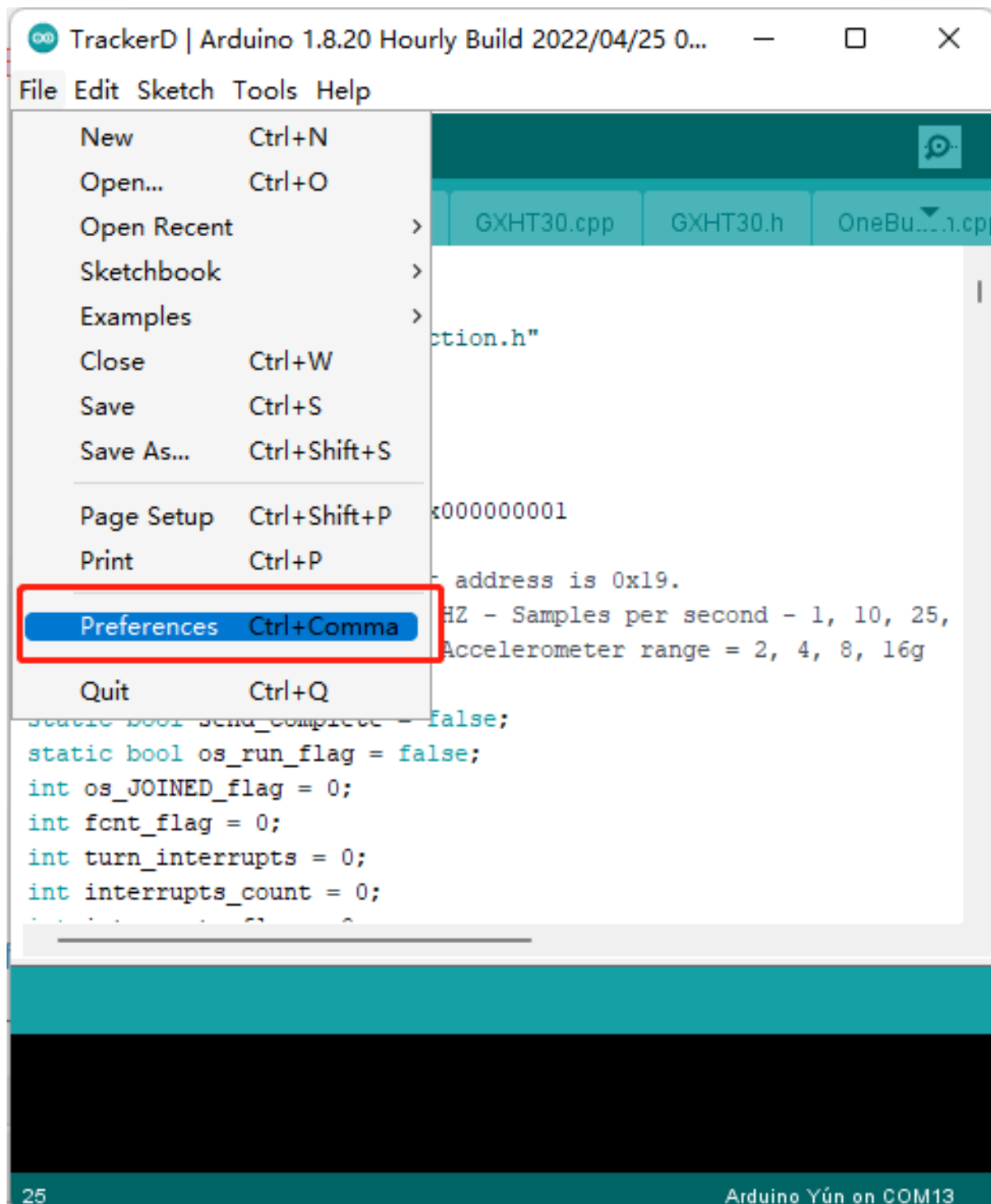

Input: https://dl.espressif.com/dl/package_esp32_index.json

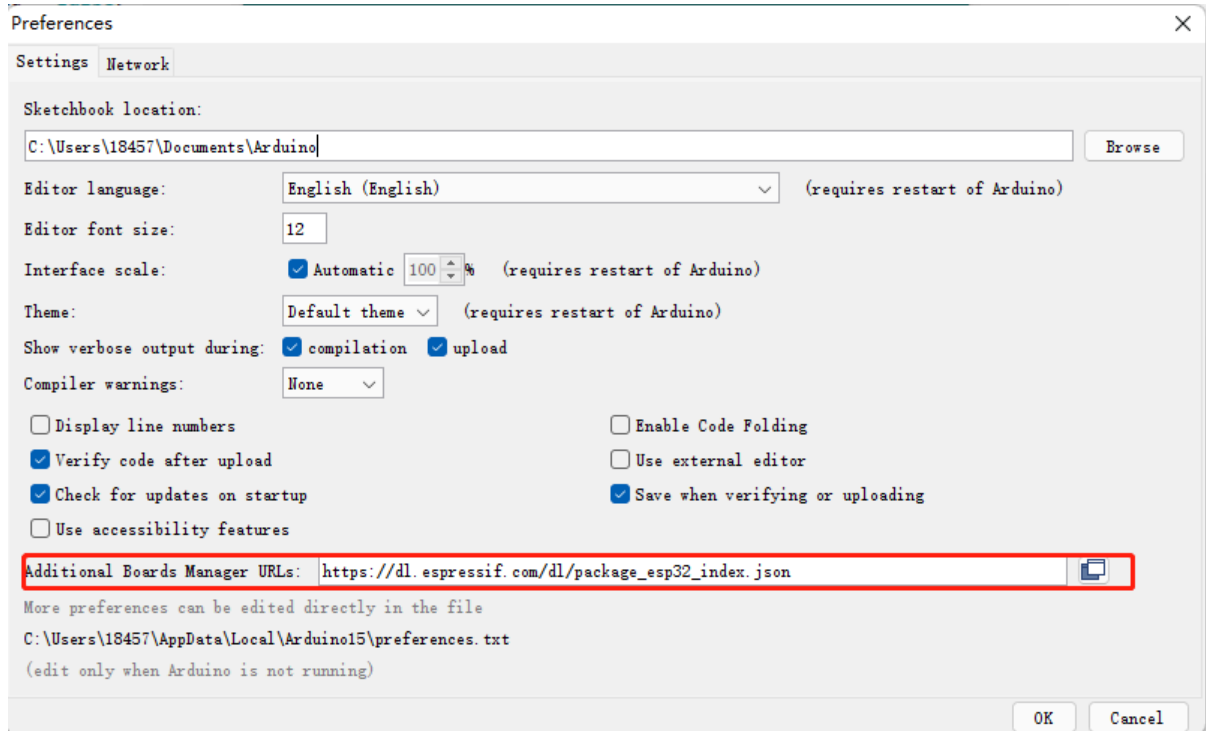

Restart the IDE after the addition is complete, then:

TrackerD | Arduino 1.8.20 Hourly Build 2022/04/25 09:33

File Edit Sketch Tools Help

The screenshot shows the Arduino IDE interface. The 'Tools' menu is open, and the 'Board' dropdown is set to 'Arduino Yún'. The 'Boards Manager...' option is highlighted. The background shows C++ code for the TrackerD project.

```

#include <SPI.h>
#include "comm.h"
#include "lis3dh.h"

#define HIGH_P
#define maxRxS
#define EXTI_P
#define BUTTON

LIS3DH myIMU(0);
uint16_t sampleRate;
uint8_t accelRate;

static bool send_complete = false;
static bool os_run_flag = false;
int os_JOINED_flag = 0;
int fcmt_flag = 0;
int turn_interrupts = 0;
int interrupts_count = 0;
int interrupts_flag = 0;
unsigned long buzzerlast = 0UL;
unsigned long Exit_Alarm = 0UL;

unsigned long sleep_last = 0UL;
static char rxData[maxRxSize]={0};
hw_timer_t * timer = NULL;
hw_timer_t * timer1 = NULL;
volatile SemaphoreHandle_t timerSemaphore;
volatile SemaphoreHandle_t timerSemaphore1;
// Saves the LMIC structure during DeepSleep
RTC_DATA_ATTR lmic_t RTC_LMIC;
RTC_DATA_ATTR int button_Count = 0;
RTC_DATA_ATTR int button_Count1 = 0;

void os_getArtEui (ul_t* buf) { sys.LORA_GetAEUI(buf);}

void os_getDevEui (ul_t* buf) { sys.LORA_GetDEUI(buf);}

void os_getDevKey (ul_t* buf) { sys.LORA_GetAKEY(buf);}

static void LORA_RxData( uint8_t *AppData,uint8_t AppData_Len);
    
```

Board: "Arduino Yún" | Boards Manager...

- Arduino Yún
- Arduino Uno
- Arduino Duemilanove or Diecimila
- Arduino Nano
- Arduino Mega or Mega 2560
- Arduino Mega ADK
- Arduino Leonardo
- Arduino Leonardo ETH
- Arduino Micro
- Arduino Esplora
- Arduino Mini
- Arduino Ethernet
- Arduino Fio
- Arduino BT
- LilyPad Arduino USB
- LilyPad Arduino
- Arduino Pro or Pro Mini
- Arduino NG or older
- Arduino Robot Control
- Arduino Robot Motor
- Arduino Gemma
- Adafruit Circuit Playground
- Arduino Yún Mini
- Arduino Industrial 101
- Linino One
- Arduino Uno WiFi

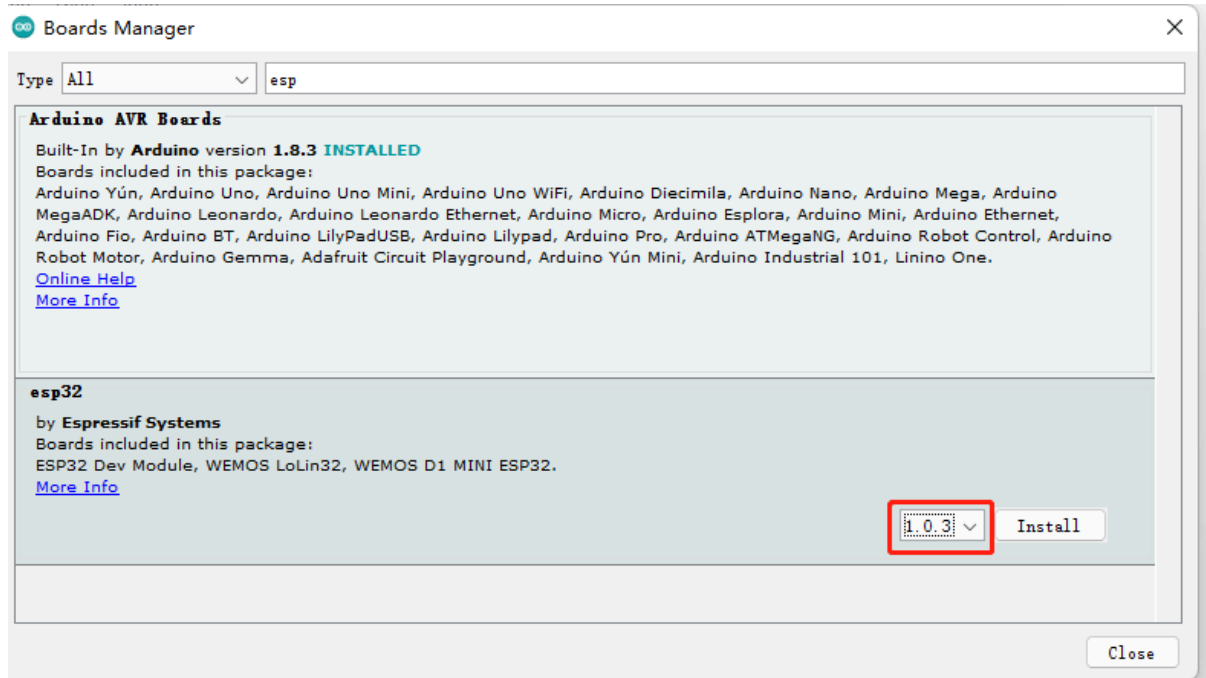

Note: Currently version 1.04 is almost impossible to download, you can choose version 1.03. Don't quit halfway.~! If you quit halfway, there is a high probability that it will freeze, and you will need to download again next time. (If you click to continue downloading, an error will be reported after completion)

Then enter a long waiting process. If you don't want to wait, you can go to the Internet to download directly, and then import:

Methods as below:

1. Download: <https://github.com/dragino/TrackerD/releases/tag/v1.4.4>
2. Find the arduino installation path, hardware → create a new espressif folder → create a new esp32 folder, unzip the compressed package here.

Find the path of SP32 installation, find the file as shown in Figure 1, and change the SPI pin to the shown in Figure 2.

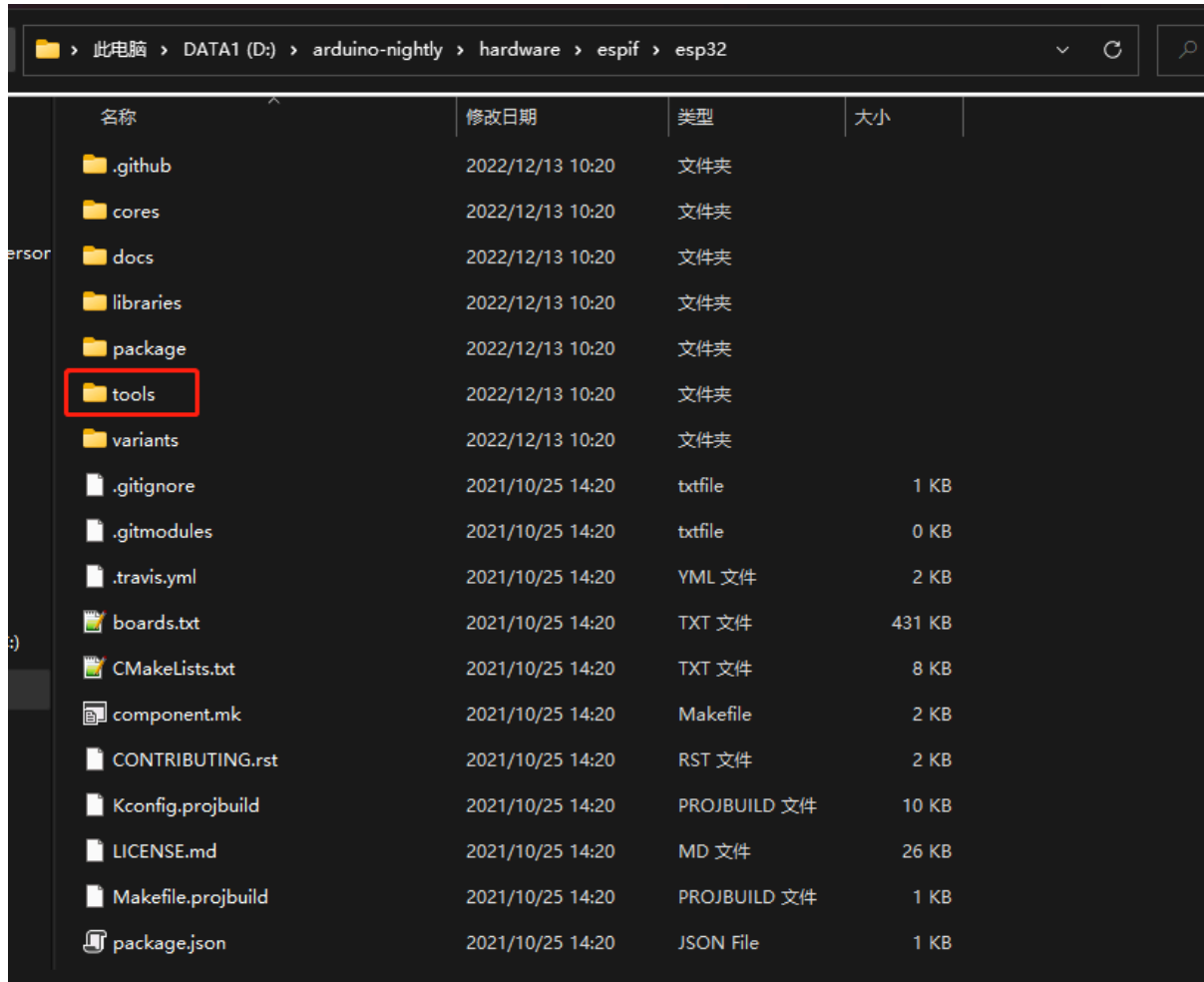

3. Find tools→get.exe in the decompressed file and run it (it will close automatically after completion)

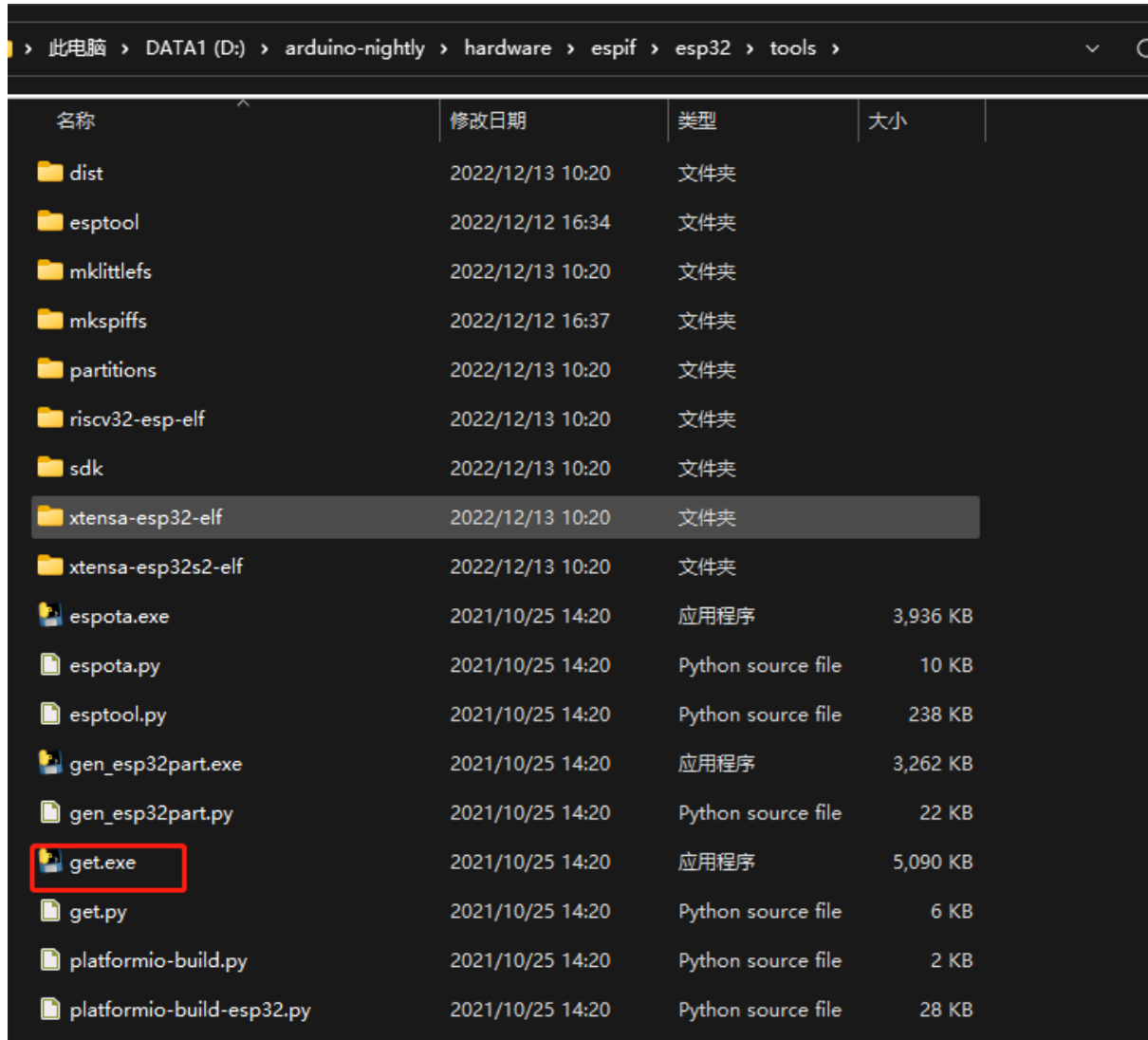

The screenshot shows a Windows File Explorer window with the following path: 此电脑 > DATA1 (D:) > arduino-nightly > hardware > espif > esp32 > tools >. The window displays a list of files and folders with columns for Name (名称), Modified Date (修改日期), Type (类型), and Size (大小). The file 'get.exe' is highlighted with a red box.

名称	修改日期	类型	大小
dist	2022/12/13 10:20	文件夹	
esptool	2022/12/12 16:34	文件夹	
mklittlefs	2022/12/13 10:20	文件夹	
mkspiiffs	2022/12/12 16:37	文件夹	
partitions	2022/12/13 10:20	文件夹	
riscv32-esp-elf	2022/12/13 10:20	文件夹	
sdk	2022/12/13 10:20	文件夹	
xtensa-esp32-elf	2022/12/13 10:20	文件夹	
xtensa-esp32s2-elf	2022/12/13 10:20	文件夹	
esptota.exe	2021/10/25 14:20	应用程序	3,936 KB
esptota.py	2021/10/25 14:20	Python source file	10 KB
esptool.py	2021/10/25 14:20	Python source file	238 KB
gen_esp32part.exe	2021/10/25 14:20	应用程序	3,262 KB
gen_esp32part.py	2021/10/25 14:20	Python source file	22 KB
get.exe	2021/10/25 14:20	应用程序	5,090 KB
get.py	2021/10/25 14:20	Python source file	6 KB
platformio-build.py	2021/10/25 14:20	Python source file	2 KB
platformio-build-esp32.py	2021/10/25 14:20	Python source file	28 KB

Note: This step requires a python environment

Either way, in the end:

The final effect is to open the arduino and you can see the esp32

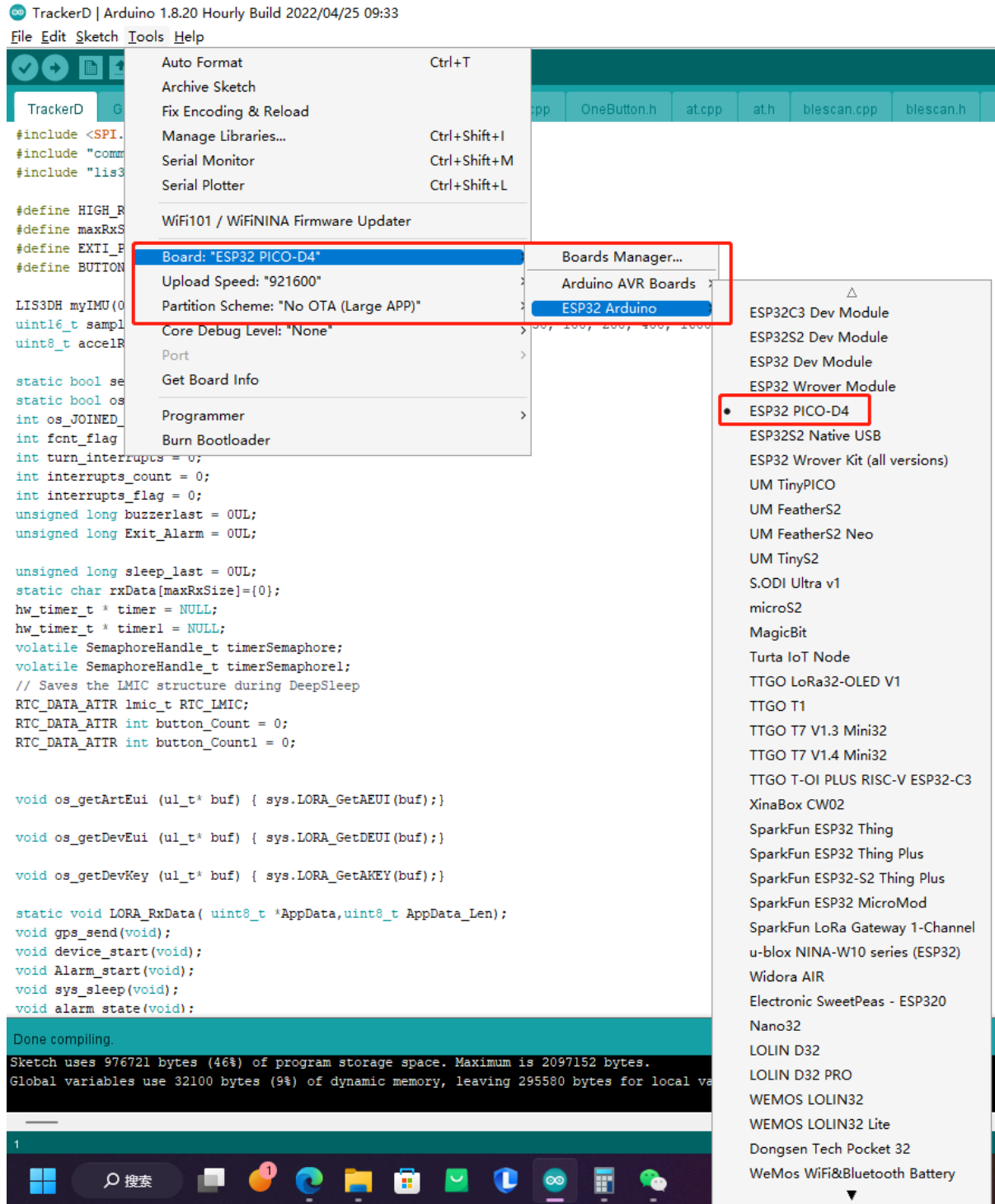

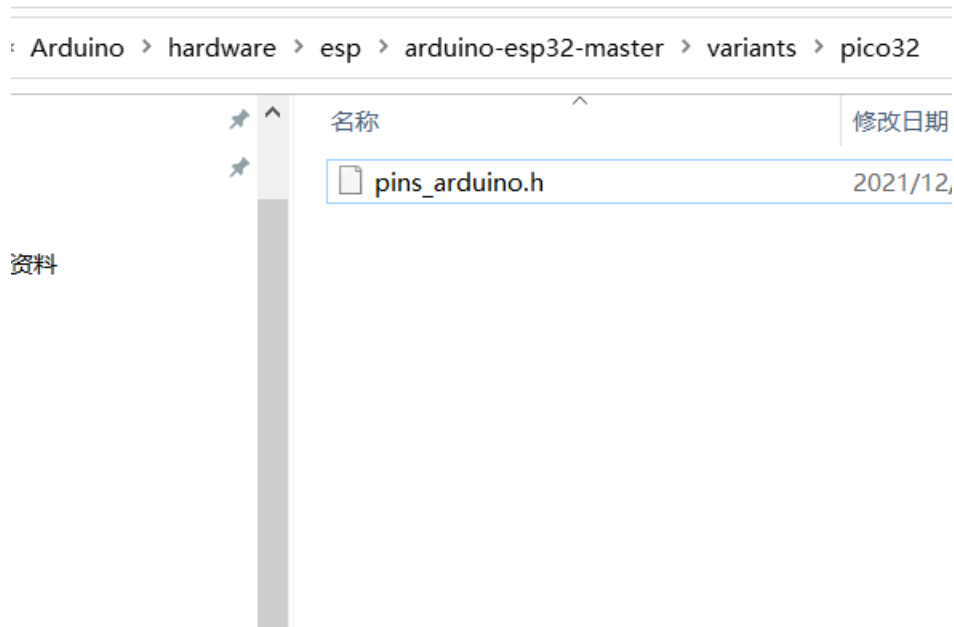

Figure1

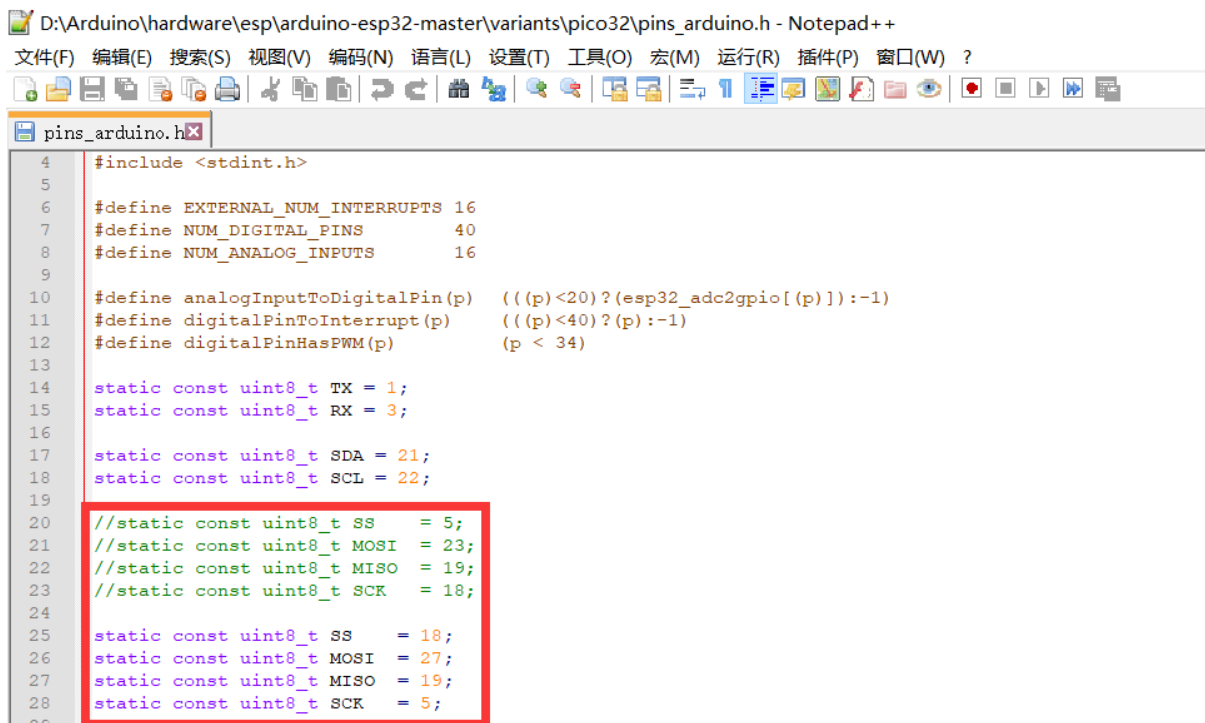

Figure2

- Download the latest TrackerD from the dragino github: <https://github.com/dragino/TrackerD>

Put the Library in the TrackerD directory into the libraries file in the Arduino directory:

› Data (D:) › Arduino › libraries

名称	修改日期
Adafruit_Circuit_Playground	2021/12/23 14:35
arduino-lmic	2022/9/19 17:35
Bridge	2021/12/23 14:35
Esplora	2021/12/23 14:35
Ethernet	2021/12/23 14:35
Firmata	2021/12/23 14:35
GSM	2021/12/23 14:35
Keyboard	2021/12/23 14:35
LiquidCrystal	2021/12/23 14:35
Mouse	2021/12/23 14:35
Robot_Control	2021/12/23 14:35
Robot_Motor	2021/12/23 14:35
RobotIRremote	2021/12/23 14:35
SD	2021/12/23 14:35
Servo	2021/12/23 14:35
SpacebrewYun	2021/12/23 14:35
Stepper	2021/12/23 14:35
Temboo	2021/12/23 14:35
TFT	2021/12/23 14:35

6.2 Source Code

- [Open the example in the TrackerD file](#), please select the correct port in the IDE, as shown below:

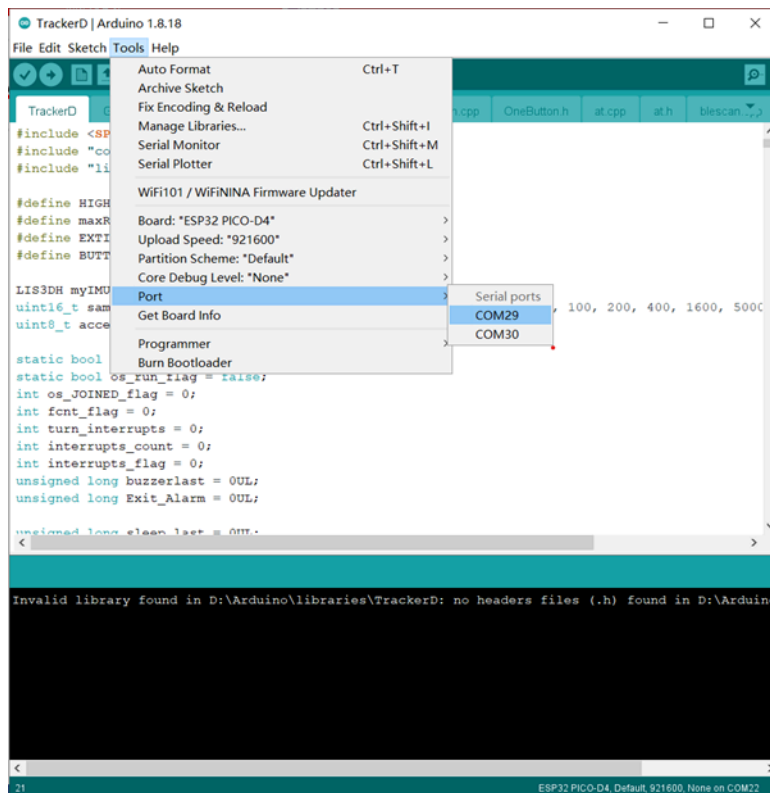

- [Click to upload](#)

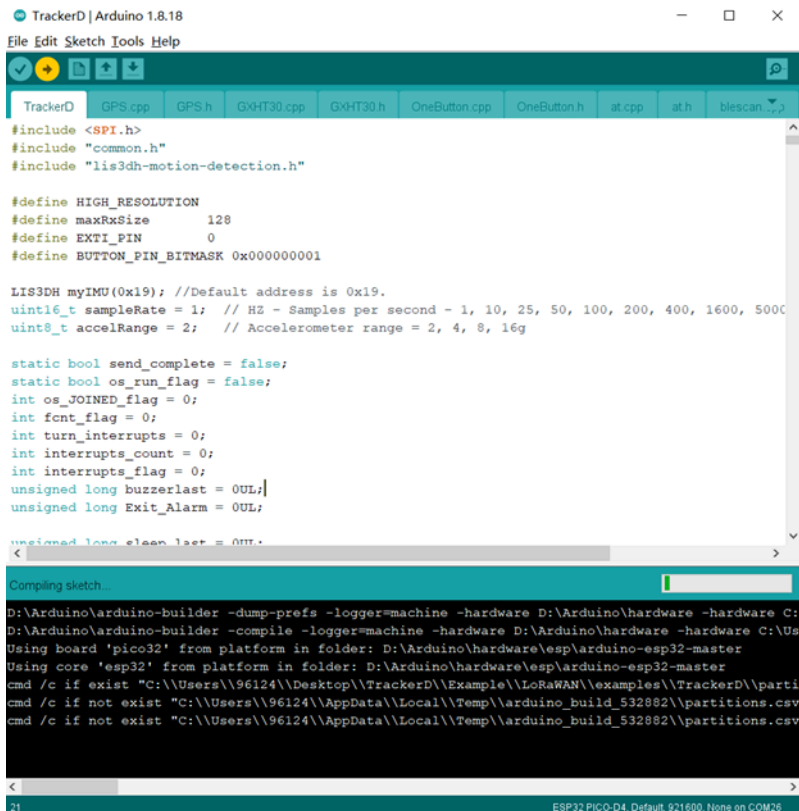

- [Check the result, if the upload is successful, as shown below, open the serial port to view the data](#)

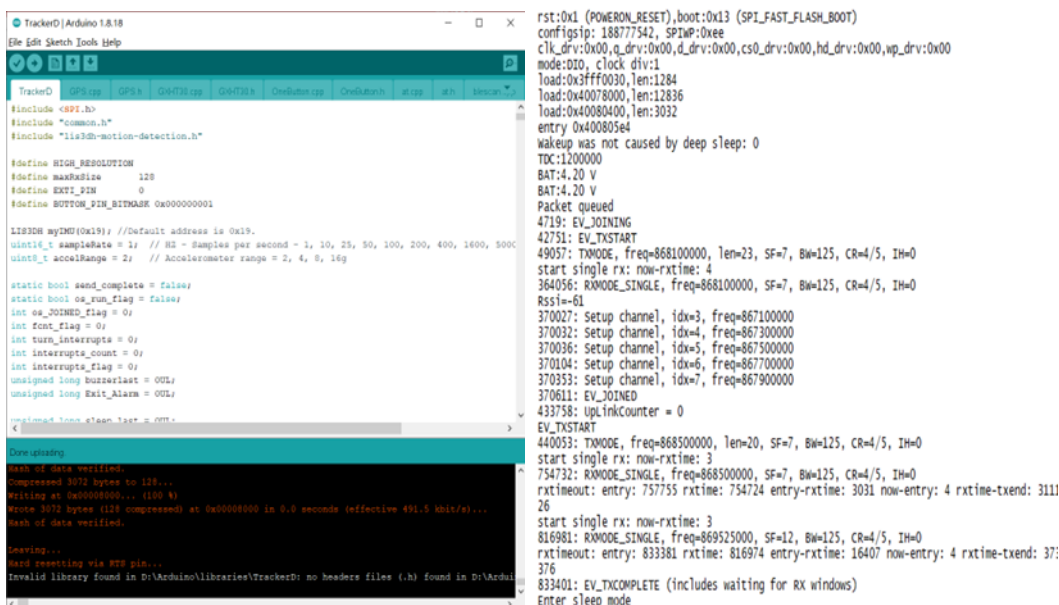

7. FAQ

7.1 How to change the LoRa Frequency Bands/Region?

User can follow the introduction for [how to upgrade image](#). When download the images, choose the required image file for download.

7.2 What is the pin mapping for the USB program cable?

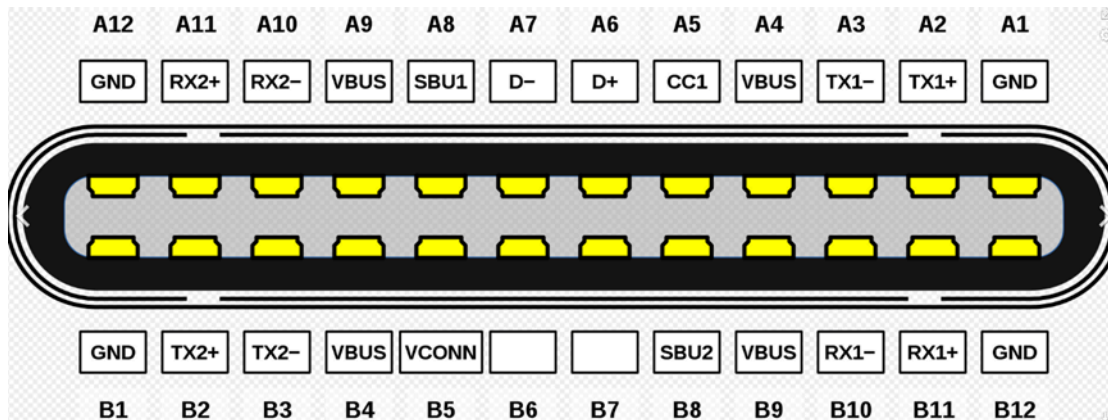

Pin	Color	USB Pin
A4,B4,A9,B9	Red	VCC
A7,B7	White	D- (N/A)
A6,B6	Green	D+(N/A)
A1,B1,A12,B12	Black	GND
A5	Purple	MTDC/GPIO13
B5	Blue	MTDC/GPIO12
A8	Yellow	MTMS/GPIO14
B8	Grey	MTDO/GPIO15

7.3 Notes on using different serial port tools for TrackerD

7.3.1 Serial port utility

Serial port utility requires you to automatically add data streams.

Need to adjust the data stream to RTS/CTS on physical restart.

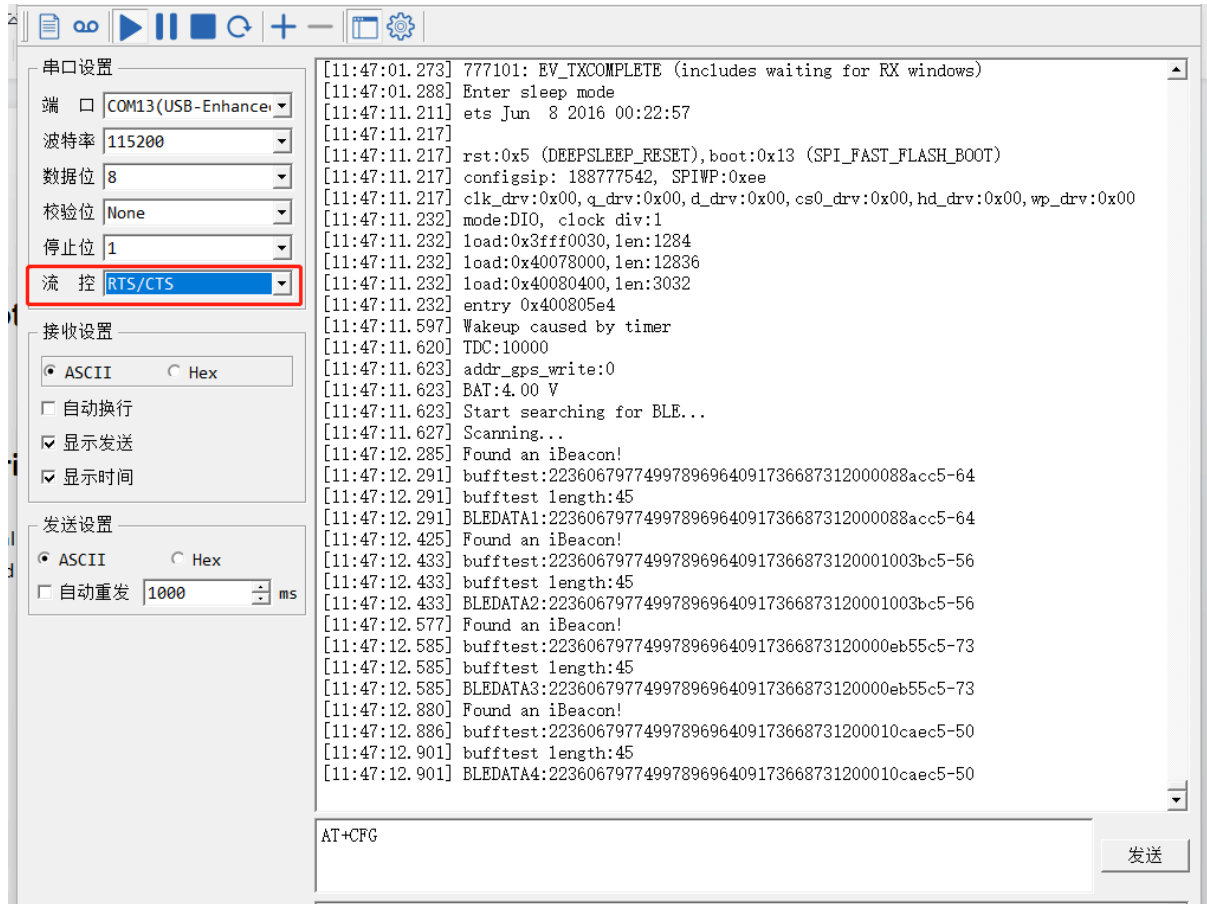

When using AT commands, the data flow needs to be adjusted to XON/XOFF

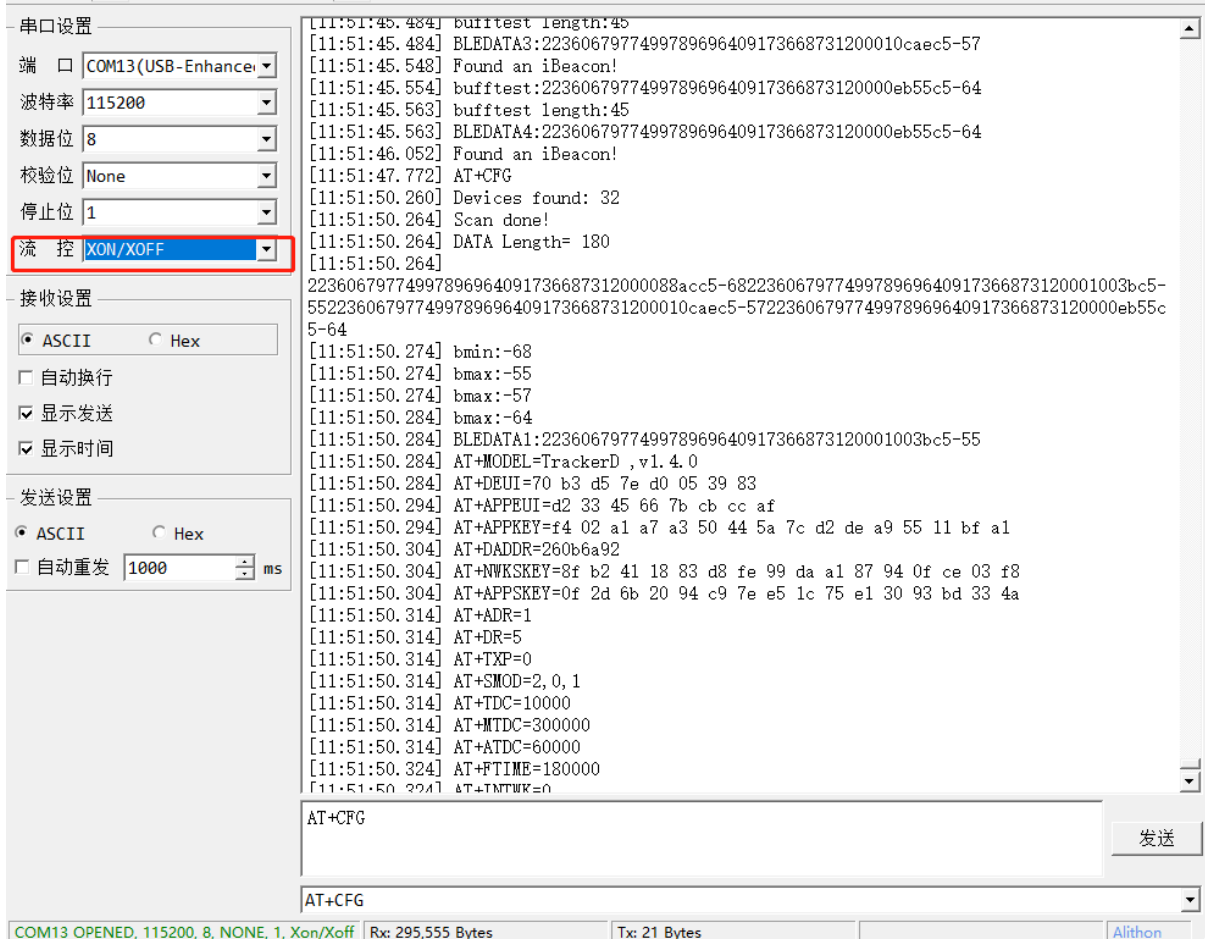

7.3.2 SecureCRT

The default command window of SecureCRT is not displayed. Entering a command requires a complete input of the entire command. You can open the command window in the view.

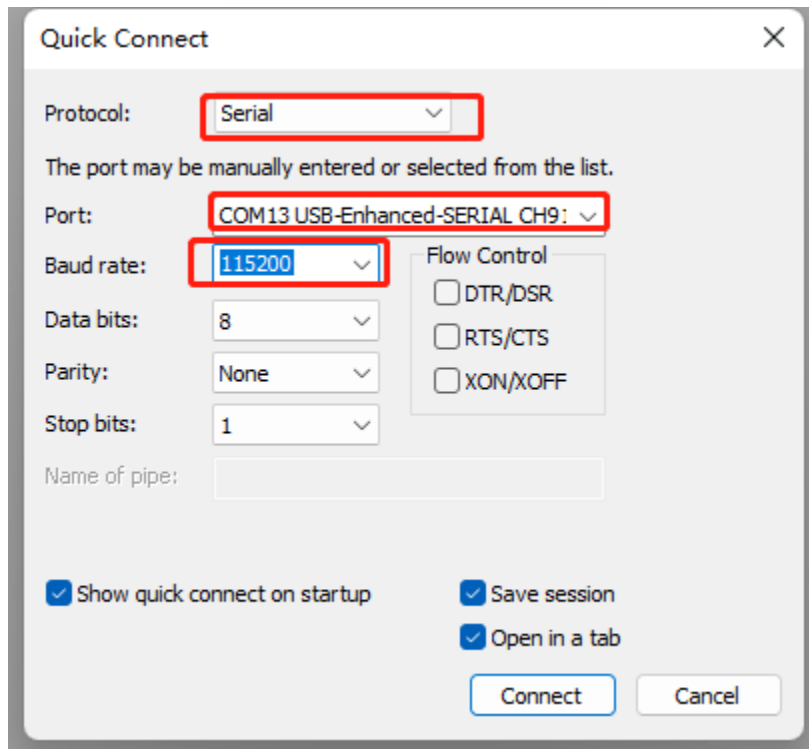

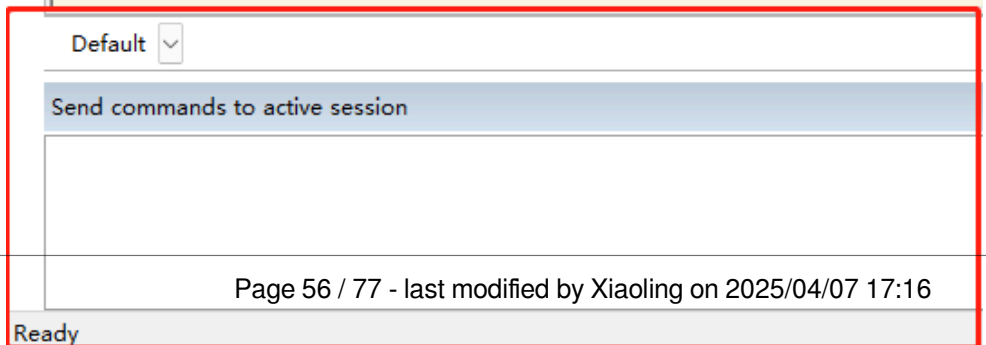
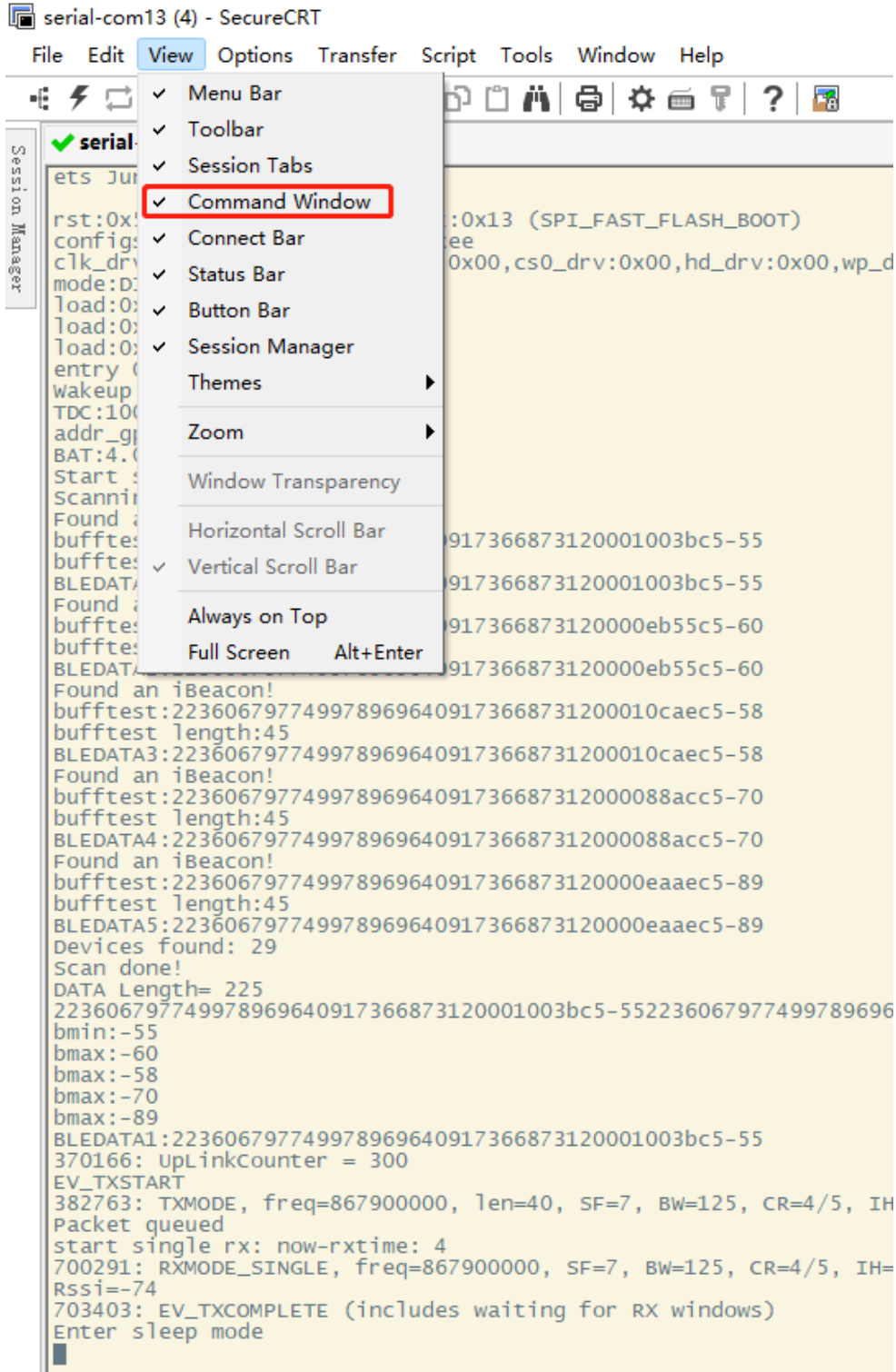

7.3.3 PUTTY

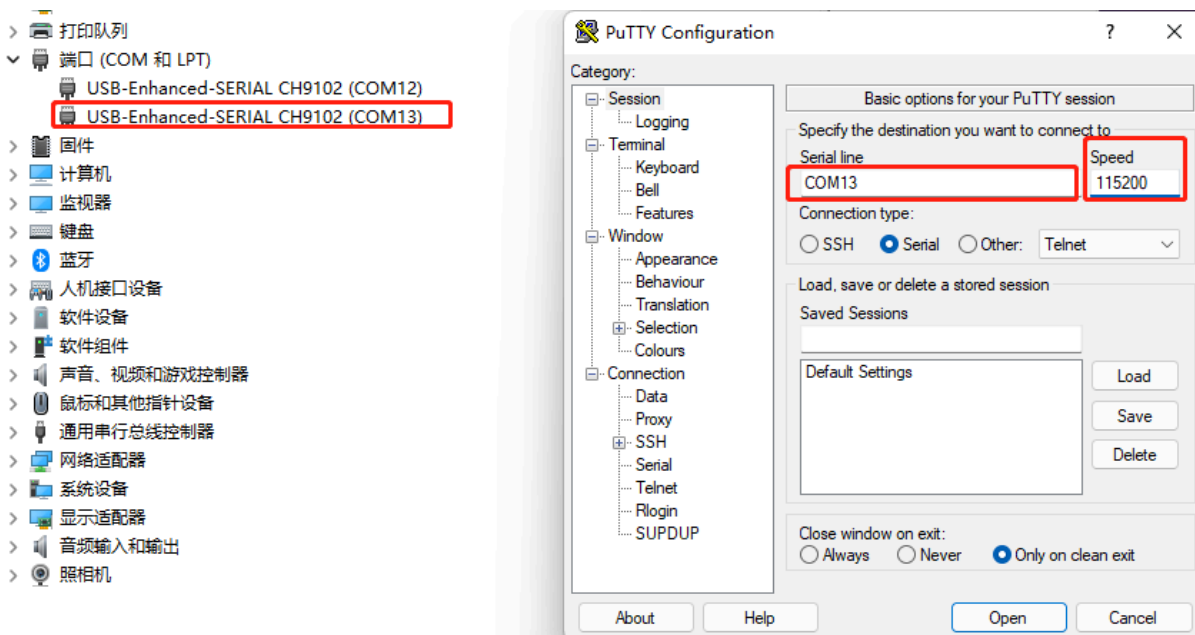

Since putty does not have a command window, you need to fill in the complete command externally, and then copy it to putty. The information copied outside can be pasted by right-clicking the mouse in putty.

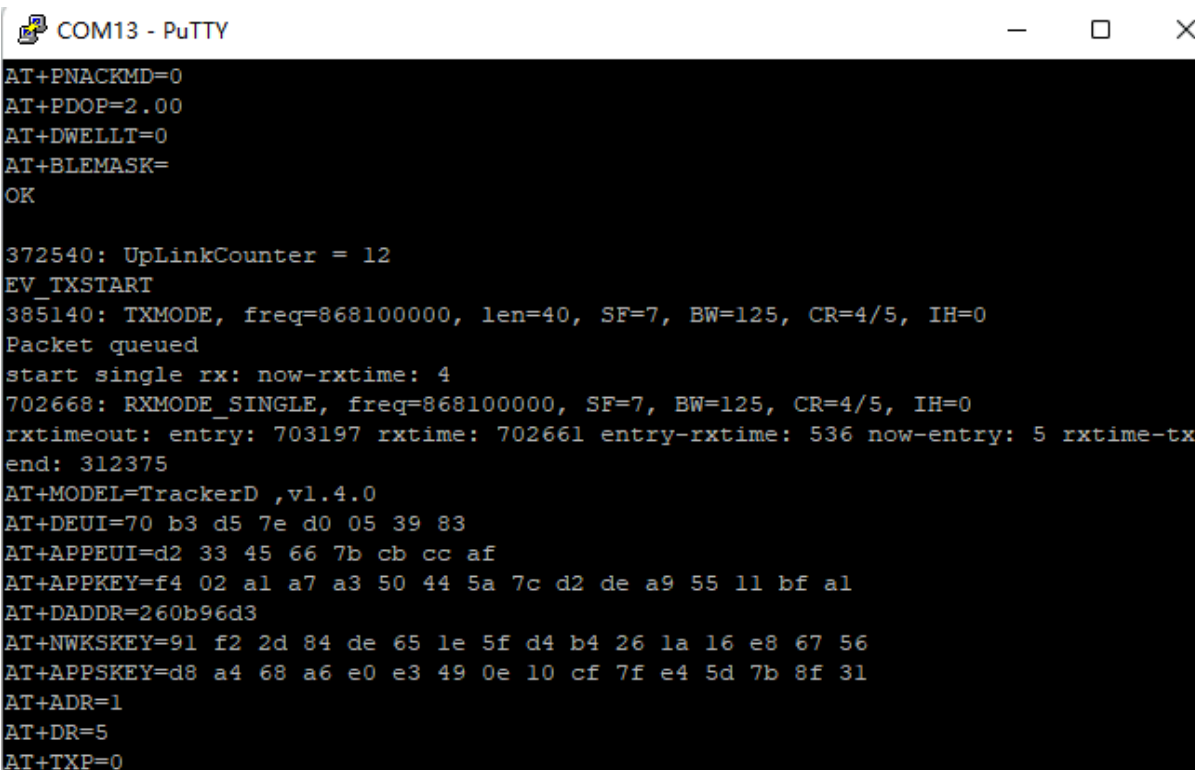

7.4 How to modify source code to compile different frequency band bin file?

Important: Developer **MUST** follow the Arduino Environment Instruction exactly include change the SPI pin mappings.

See : [Set Up Arduino Compile Environment for TrackerD.](#)

1. When compiling the frequency band, you need to find LMIC_PROJECT_CONFIG.H file.

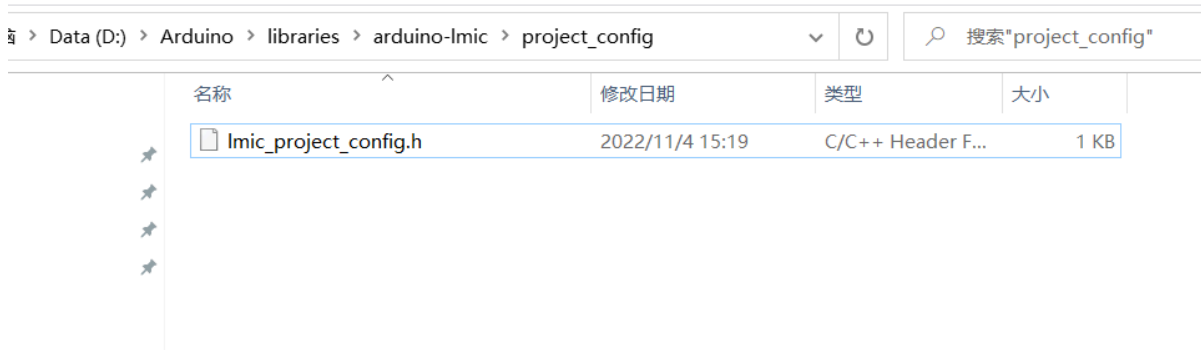

2. Open LMIC_PROJECT_CONFIG.H, find the corresponding macro definition and open it(AS923_2,AS923_3,AS923_4 except).

```
lmic_project_config.h
1 // project-specific definitions
2 #define CFG_eu868 1
3 //#define CFG_us915 1
4 //#define CFG_au915 1
5 //#define CFG_as923 1
6 // #define LMIC_COUNTRY_CODE LMIC_COUNTRY_CODE_JP /* for as923-JP; also define CFG_as923 */
7 //#define CFG_kr920 1
8 //#define CFG_in866 1
9 //#define CFG_kz865 1
10 //#define CFG_ru864 1
11 //#define CFG_ma869 1
12 #define CFG_sx1276_radio 1
13
14 #define LMIC_DEBUG_LEVEL 2
15 //#define LMIC_USE_INTERRUPTS
16
```

3. Compile the AS923_JP band, please refer to the intention shown

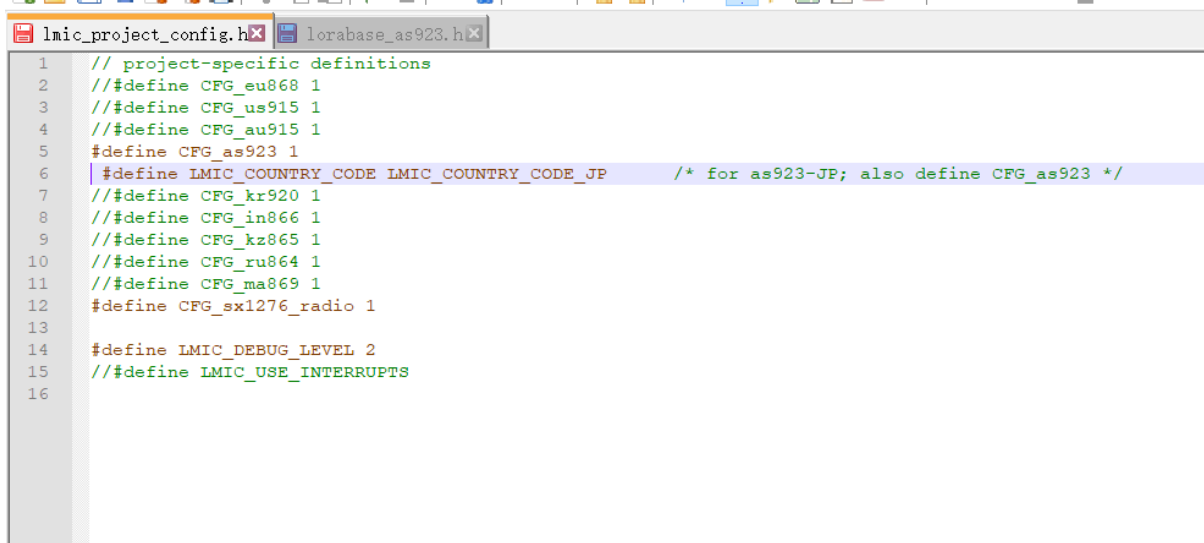

```
1 // project-specific definitions
2 //#define CFG_eu868 1
3 //#define CFG_us915 1
4 //#define CFG_au915 1
5 #define CFG_as923 1
6 #define LMIC_COUNTRY_CODE LMIC_COUNTRY_CODE_JP /* for as923-JP; also define CFG_as923 */
7 //#define CFG_kr920 1
8 //#define CFG_in866 1
9 //#define CFG_kz865 1
10 //#define CFG_ru864 1
11 //#define CFG_ma869 1
12 #define CFG_sx1276_radio 1
13
14 #define LMIC_DEBUG_LEVEL 2
15 //#define LMIC_USE_INTERRUPTS
16
```

4. In other frequency bands in AS923, you need to find Lorabase_as923.H, path arduino-lmic \src \lmic, as shown in the figure below.

Data (D:) > Arduino > libraries > arduino-lmic > src > lmic

搜索"lmic"

名称	修改日期	类型	大小
lmic_bandplan_kr920.h	2021/10/11 11:38	C/C++ Header F...	4 KB
lmic_bandplan_kz865.h	2022/8/26 17:48	C/C++ Header F...	4 KB
lmic_bandplan_ma869.h	2022/8/29 15:00	C/C++ Header F...	4 KB
lmic_bandplan_ru864.h	2022/8/29 14:18	C/C++ Header F...	4 KB
lmic_bandplan_us915.h	2021/10/11 11:38	C/C++ Header F...	4 KB
lmic_channelshuffle.c	2021/10/11 11:38	C Source File	7 KB
lmic_compat.h	2021/10/11 11:38	C/C++ Header F...	5 KB
lmic_compliance.c	2021/10/11 11:38	C Source File	22 KB
lmic_compliance.h	2021/10/11 11:38	C/C++ Header F...	5 KB
lmic_config_preconditions.h	2022/8/29 15:55	C/C++ Header F...	12 KB
lmic_env.h	2021/10/11 11:38	C/C++ Header F...	8 KB
lmic_eu_like.c	2021/10/11 11:38	C Source File	12 KB
lmic_eu_like.h	2021/10/11 11:38	C/C++ Header F...	5 KB
lmic_eu868.c	2021/10/11 11:38	C Source File	14 KB
lmic_in866.c	2021/10/11 11:38	C Source File	10 KB
lmic_kr920.c	2021/10/11 11:38	C Source File	11 KB
lmic_kz865.c	2022/8/29 14:35	C Source File	10 KB
lmic_ma869.c	2022/8/29 16:14	C Source File	10 KB
lmic_ru864.c	2022/8/29 14:13	C Source File	13 KB
lmic_us_like.c	2021/10/11 11:38	C Source File	15 KB
lmic_us_like.h	2021/10/11 11:38	C/C++ Header F...	6 KB
lmic_us915.c	2021/10/11 11:38	C Source File	10 KB
lmic_util.c	2021/10/11 11:38	C Source File	10 KB
lmic_util.h	2021/10/11 11:38	C/C++ Header F...	1 KB
lorabase.h	2022/8/29 15:46	C/C++ Header F...	28 KB
lorabase_as923.h	2022/8/31 10:30	C/C++ Header F...	6 KB
lorabase_au915.h	2022/9/2 11:20	C/C++ Header F...	4 KB
lorabase_eu868.h	2021/10/11 11:38	C/C++ Header F...	4 KB

```

10  * * Redistributions of source code must retain the above copyright
11  *   notice, this list of conditions and the following disclaimer.
12  * * Redistributions in binary form must reproduce the above copyright
13  *   notice, this list of conditions and the following disclaimer in the
14  *   documentation and/or other materials provided with the distribution.
15  * * Neither the name of the <organization> nor the
16  *   names of its contributors may be used to endorse or promote products
17  *   derived from this software without specific prior written permission.
18  *
19  * THIS SOFTWARE IS PROVIDED BY THE COPYRIGHT HOLDERS AND CONTRIBUTORS "AS IS" AND
20  * ANY EXPRESS OR IMPLIED WARRANTIES, INCLUDING, BUT NOT LIMITED TO, THE IMPLIED
21  * WARRANTIES OF MERCHANTABILITY AND FITNESS FOR A PARTICULAR PURPOSE ARE
22  * DISCLAIMED. IN NO EVENT SHALL <COPYRIGHT HOLDER> BE LIABLE FOR ANY
23  * DIRECT, INDIRECT, INCIDENTAL, SPECIAL, EXEMPLARY, OR CONSEQUENTIAL DAMAGES
24  * (INCLUDING, BUT NOT LIMITED TO, PROCUREMENT OF SUBSTITUTE GOODS OR SERVICES;
25  * LOSS OF USE, DATA, OR PROFITS; OR BUSINESS INTERRUPTION) HOWEVER CAUSED AND
26  * ON ANY THEORY OF LIABILITY, WHETHER IN CONTRACT, STRICT LIABILITY, OR TORT
27  * (INCLUDING NEGLIGENCE OR OTHERWISE) ARISING IN ANY WAY OUT OF THE USE OF THIS
28  * SOFTWARE, EVEN IF ADVISED OF THE POSSIBILITY OF SUCH DAMAGE.
29  */
30
31 #ifndef _lorabase_as923_h_
32 #define _lorabase_as923_h_
33
34 #ifndef _LMIC_CONFIG_PRECONDITIONS_H_
35 # include "lmic_config_preconditions.h"
36 #endif
37
38 #define AS923_2 1
39 // #define AS923_3 1
40 // #define AS923_4 1
41 /*****\
42 |
43 | Basic definitions for AS923 (always in scope)
44 |
45 | \*****/
46

```

7.5 Are there example python example for BLE Indoor Positioning?

[Operating instructions for BLE indoor positioning](#)

7.6 Can alert mode and transport mode be used together?

Yes, you can also press the panic button to sound the alarm if set to transport mode

7.7 Can i get the datalog record from console?

Since firmware TrackerD-v1.4.9, User is able to get the datalog record from console as well.

```

configsip: 188777542, SPIWP:0xee
clk_drv:0x00,q_drv:0x00,d_drv:0x00,cs0_drv:0x00,hd_drv:
0x00,wp_drv:0x00
mode:DIO, clock div:1
load:0x3fff0030,len:1284
load:0x40078000,len:12836
load:0x40080400,len:3032
entry 0x400805e4
Wakeup caused by timer
TDC:3600000
BAT:3318 mV
datalog count:2
GPS DATA:01 5a 79 66 06 cf 31 90 07 e8 03 1d 03 00 0a 00
00
addr_gps_read:17
3509: UpLinkCounter = 1
EU_TXSTART
16066: TXMODE, freq=905500000, len=33, SF=9, BW=125,
CR=4/5, IH=0
Packet queued
2
01 5a 79 66 06 cf 31 90 07 e8 03 1d 03 00 0a 00 00
addr_pdta_read:17
01 5a 79 c6 06 cf 31 48 07 e8 03 1d 03 01 02 00 00
addr pdta read:34
AT+PDTA=2

```

This shows how many pieces of data are recorded in the datalog.

Enter AT+PDTA=2 to display the actual stored data

7.8 FAQs for upgrading to version 1.4.9 or later

1.The device does not display version information or indicates low battery

Please set the device type

AT+DEVICE=13-->TrackerD
AT+DEVICE=22->TrackerD-LS

2.Unable to control the red button on trackerD

Due to the integration of the old and new versions of the software, we have added a judgment condition to the software. Sometimes it is necessary to judge the old and new versions and then the red button function can be used normally.

- For V1.4.9 and earlier versions, you need to set an 8-bit DADDR equal to or less than **01880788**.

Example:

AT+DADDR=01880688

- For new versions after V1.4.9, the user needs to set an 8-bit DADDR greater than **01880788**.

Example:

AT+DADDR=01880789

8 Trouble Shooting

8.1 TDC is changed to 4294947296 and cause no uplink.

Before firmware v1.4.0: When the Transport Mode is enabled (**AT+INTWK=1**), the **TDC** needs to be greater than **MTDC**, otherwise, TDC setting will because 4294947296 after wakre up from motion. This bug is fixed in firmware v1.4.1

8.2 Device not able get AT Command or show output after wake up from deep sleep mode

ESP32 is not able to accept the Interrupt from UART after wake up from deep sleep mode. User need to press the button (one click) and trackerD will be able to accept UART command, it there is no action in UART for 15 seconds. it will go to deep sleep mode.

8.3 Problem after Upgrading Firmware

8.3.1 "rst: (0x3 SW_RESET)" and Continue Restart after upgrading

Error Output

```
mode:DIO, clock div:1
load:0x3fff0030,len:1284
load:0x40078000,len:12836
load:0x40080400,len:3032
entry 0x400805e4
ets Jun  8 2016 00:22:57

rst:0x3 (SW_RESET),boot:0x13 (SPI_FAST_FLASH_BOOT)
configsip: 188777542, SPIWP:0xee
clk_drv:0x00,q_drv:0x00,d_drv:0x00,cs0_drv:0x00,hd_drv:0x00,wp_drv:0x00
mode:DIO, clock div:1
load:0x3fff0030,len:1284
load:0x40078000,len:12836
load:0x40080400,len:3032
entry 0x400805e4
ets Jun  8 2016 00:22:57

rst:0x3 (SW_RESET),boot:0x13 (SPI_FAST_FLASH_BOOT)
configsip: 188777542, SPIWP:0xee
clk_drv:0x00,q_drv:0x00,d_drv:0x00,cs0_drv:0x00,hd_drv:0x00,wp_drv:0x00
mode:DIO, clock div:1
load:0x3fff0030,len:1284
load:0x40078000,len:12836
load:0x40080400,len:3032
entry 0x400805e4
ets Jun  8 2016 00:22:57

rst:0x3 (SW_RESET),boot:0x13 (SPI_FAST_FLASH_BOOT)
configsip: 188777542, SPIWP:0xee
clk_drv:0x00,q_drv:0x00,d_drv:0x00,cs0_drv:0x00,hd_drv:0x00,wp_drv:0x00
mode:DIO, clock div:1
load:0x3fff0030,len:1284
load:0x40078000,len:12836
load:0x40080400,len:3032
entry 0x400805e4
```

Some partition is missed during upgrade, please upgrade below four files as example:

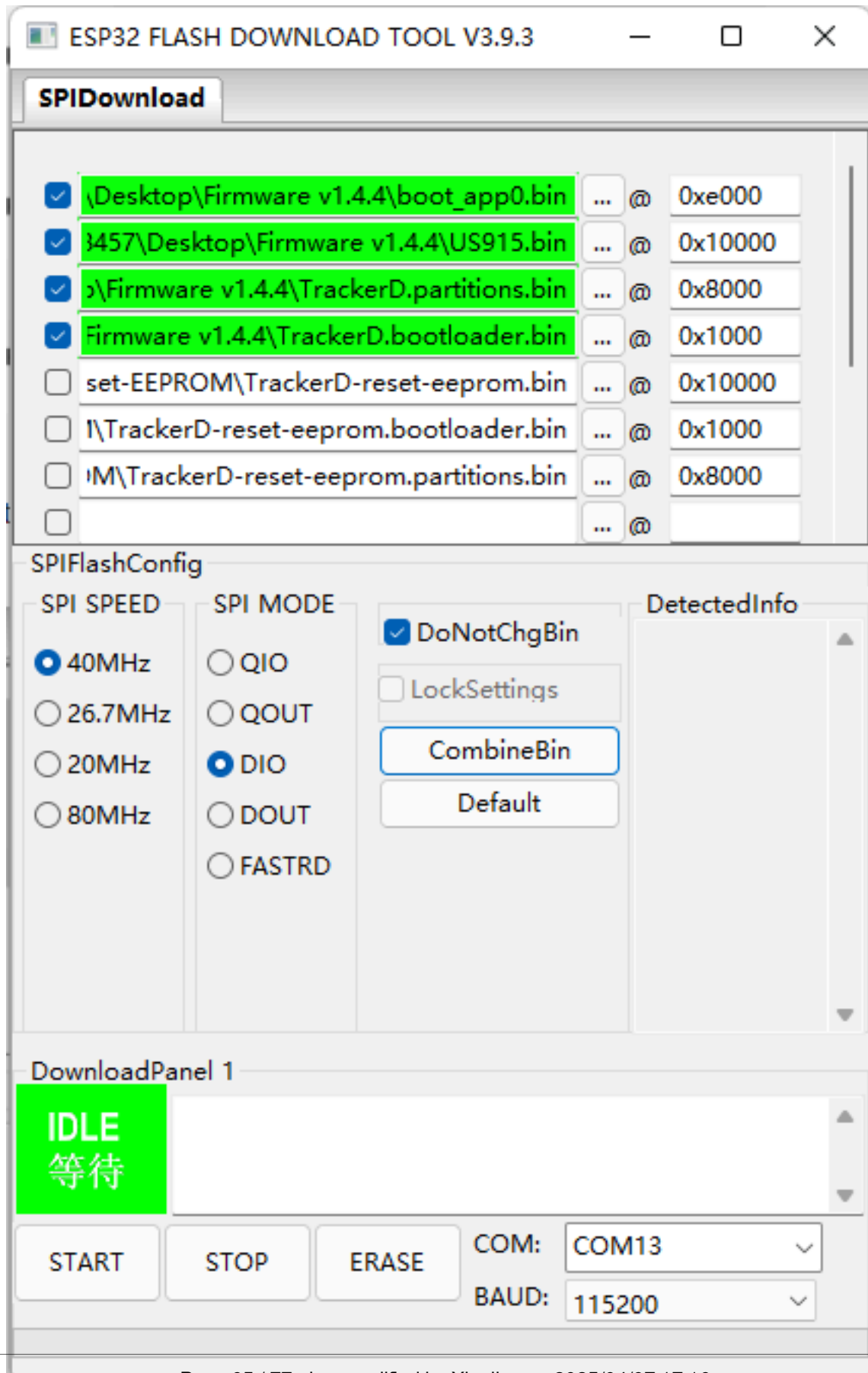

8.3.2 TrackerD's led light is always GREEN on after upgrading

It is because the partitions are different when upgrading versions above 1.4.1, and a new partition file needs to be added. Please refer to the operation steps in chapter 8.3.1

8.3.3 "flash read err" after upgrade firmware

Error shows below, user might erase the entire flash include u-boot partition which cause this issue.

```
rst:0x1 (POWERON_RESET),boot:0x13 (SPI_FAST_FLASH_BOOT)
flash read err, 1000
ets_main.c 371
ets Jun  8 2016 00:22:57

rst:0x10 (RTCWDT_RTC_RESET),boot:0x13 (SPI_FAST_FLASH_BOOT)
flash read err, 1000
ets_main.c 371
ets Jun  8 2016 00:22:57

rst:0x10 (RTCWDT_RTC_RESET),boot:0x13 (SPI_FAST_FLASH_BOOT)
flash read err, 1000
ets_main.c 371
ets Jun  8 2016 00:22:57

rst:0x10 (RTCWDT_RTC_RESET),boot:0x13 (SPI_FAST_FLASH_BOOT)
flash read err, 1000
ets_main.c 371
ets Jun  8 2016 00:22:57

rst:0x10 (RTCWDT_RTC_RESET),boot:0x13 (SPI_FAST_FLASH_BOOT)
flash read err, 1000
ets_main.c 371
ets Jun  8 2016 00:22:57

rst:0x10 (RTCWDT_RTC_RESET),boot:0x13 (SPI_FAST_FLASH_BOOT)
flash read err, 1000
ets_main.c 371
ets Jun  8 2016 00:22:57
```

User need to upgrade again with below four files to solve this issue.

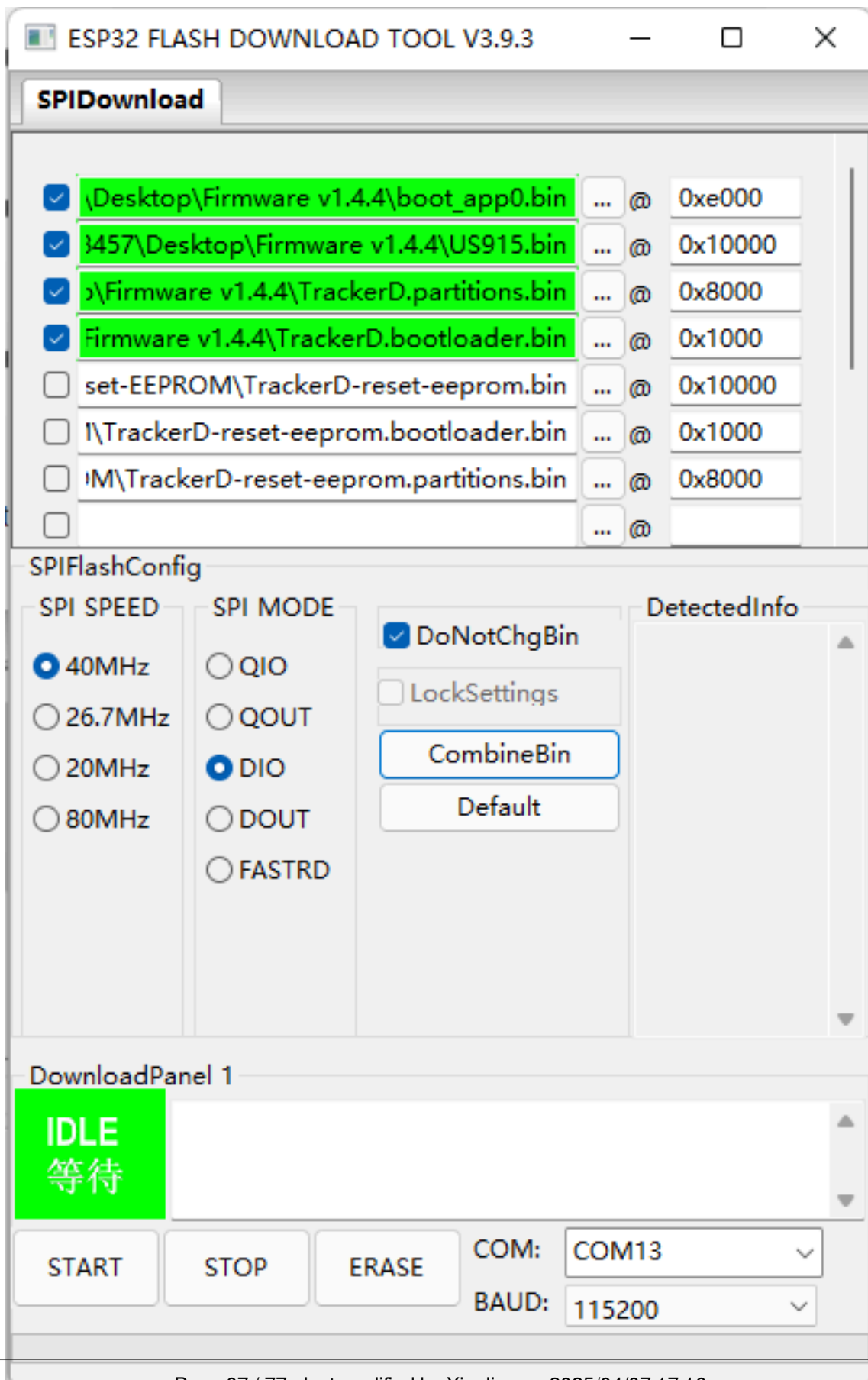

Figure 2

8.3.4 "Device Key become ff ff ff ff ff ff ff " after upgrade firmware

User might erase the entire flash include keys and default settings which cause this issue.

After the upgrade is completed, enter **AT+CFG** as shown in the figure below.

```

100/0: 1MODEL, freq=903/00000, len=23, sr=10, bw=125, cr=4/5, ih=0
AT+MODEL=TrackerD ,v1.4.2
AT+DEUI=ff ff ff ff ff ff ff ff
AT+APPEUI=ff ff ff ff ff ff ff ff
AT+APPKEY=ff ff ff ff ff ff ff ff ff ff ff ff ff ff ff ff ff
AT+DADDR=ffffffff
AT+NWKSKEY=ff ff ff ff ff ff ff ff ff ff ff ff ff ff ff ff
AT+APPSKEY=ff ff ff ff ff ff ff ff ff ff ff ff ff ff ff ff
AT+ADR=0
AT+DR=255
AT+TXP=255
AT+SMOD=255,255,255
AT+TDC=4294967295
AT+MTDC=4294967295
AT+ATDC=4294967295
AT+FTIME=4294967295
AT+INTWK=255
AT+LON=255
AT+CHE=255
AT+NMEA353=255
AT+NMEA886=255
AT+CFM=255
AT+PNACKMD=255
AT+PDOP=255.00
AT+DWELLT=255
AT+SHOWID=0
AT+BLEMASK=
AT+wifimask=

OK

```

Please **AT+FDR** which will reset all settings to factory settings. , and then input the following keys by the information on the label.

After AT+FDR. please set

- **AT+PDOP=7**
- **AT+FTIME=180000**

Example:

AT+PDOP=7.00

AT+FTIME=180

AT+DEUI=70B3D57ED0053981

AT+APPEUI=D23345667BCBCCAF

AT+APPKEY=F402A1A7A350445A7CD2DEA95511BFA1

AT+DADDR=260b4dce (no need for OTAA)

AT+NWKSKEY=71cb7672441f573a53d4f34d307fc61d (no need for OTAA)

AT+APPSKEY=dacce2299ecd97a73ee3f80b5a46a559 (no need for OTAA)

8.4 When positioning, it will restart or the PDOP setting is unsuccessful

Please download version 1.4.2 again

8.5 How to deal with unsuccessful GPS positioning?

- 1) Make Sure the device is in Open Area where can see the sky.
- 2) Set PDOP to a higher value.
 - **AT+PDOP=2** (can be positioned *precisely*.)
 - **AT+PDOP=7** (Quickly locate in open *spaces*)
 - **AT+PDOP=14.7** (Positioning can be acquired in complex *environments*)

Please refer to this [link](#) on how to set up PDOP

8.6 When upgrading the firmware, the data is not completely erased, and the information does not return to normal after multiple resets

When upgrading, use the erase button to upgrade

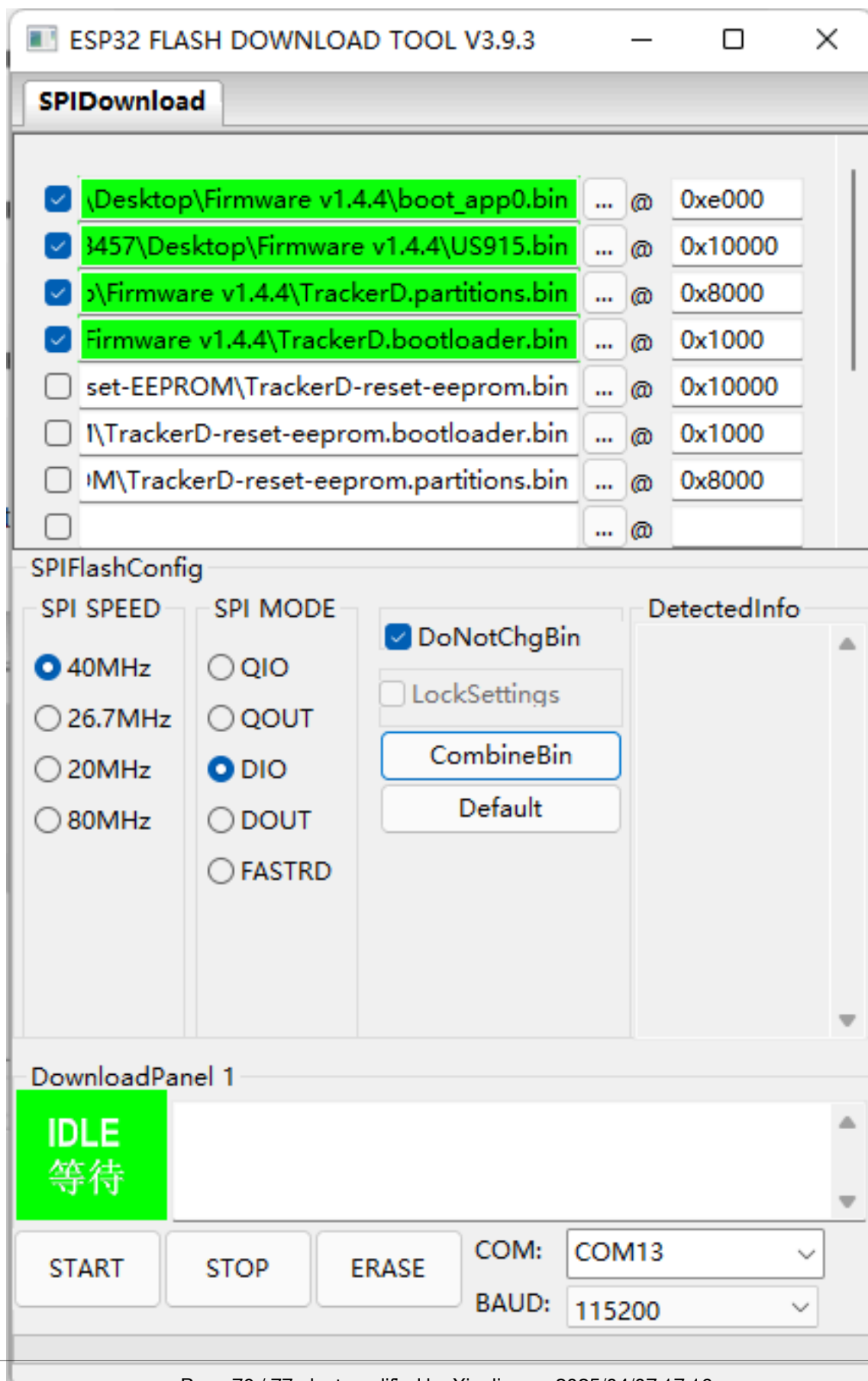

The parameters are displayed abnormally and cannot be fixed using AT+FDR

```
[17:10:39.865] AT+CFG
[17:10:39.874] AT+MODEL=TrackerD ,v1.4.3
[17:10:39.877] AT+DEUI=ff ff ff ff ff ff ff aa
[17:10:39.877] AT+APPEUI=ff ff ff ff ff ff ff aa
[17:10:39.887] AT+APPKEY=ff ff ff ff ff ff ff ff ff ff ff ff ff ff ff ff aa
[17:10:39.887] AT+DADDR=260b5151
[17:10:39.887] AT+NWKSKEY=a9 b5 f6 84 d4 26 7a b0 6e a3 b7 26 31 7f 3d 4f
[17:10:39.896] AT+APPSKEY=fd a0 3d c0 69 c3 60 de 12 fb 30 5f 90 e9 b4 8f
[17:10:39.906] AT+ADR=0
[17:10:39.906] AT+DR=255
[17:10:39.906] AT+TXP=255
[17:10:39.906] AT+SMOD=1, 0, 0
[17:10:39.906] AT+TDC=60
[17:10:39.906] AT+MTDC=4294967295
[17:10:39.906] AT+ATDC=4294967295
[17:10:39.917] AT+FTIME=180000
[17:10:39.917] AT+INTWK=255
[17:10:39.917] AT+LON=255
[17:10:39.917] AT+CHE=255
[17:10:39.917] AT+NMEA353=255
[17:10:39.917] AT+NMEA886=255
[17:10:39.917] AT+CFM=255
[17:10:39.917] AT+PNACKMD=255
[17:10:39.920] AT+PDOP=7.00
[17:10:39.926] AT+DWELLT=255
[17:10:39.926] AT+SHOWID=0
[17:10:39.926] AT+RI RMASK=
```

Please upgrade these four files, [link](#) (The boot_app0 file is in the version folder you need)

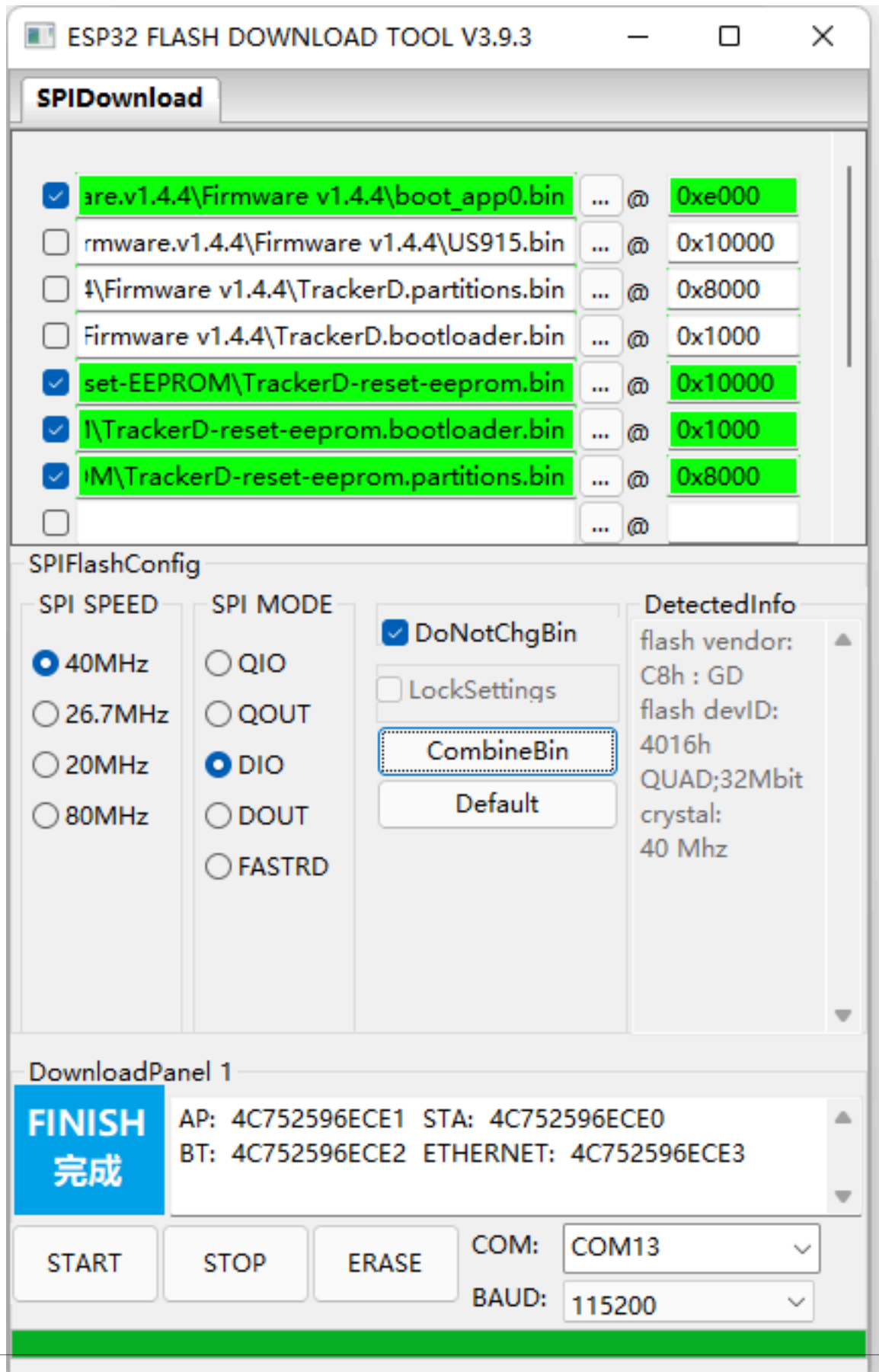

Reboot information after upgrade

```
[11:00:27.377] ets Jun  8 2016 00:22:57
[11:00:27.380]
[11:00:27.380] rst:0xc (SW_CPU_RESET),boot:0x13 (SPI_FAST_FLASH_BOOT)
[11:00:27.390] configsip: 188777542, SPIWP:0xee
[11:00:27.390] clk_drv:0x00, q_drv:0x00, d_drv:0x00, cs0_drv:0x00, hd_drv:
0x00, wp_drv:0x00
[11:00:27.390] mode:DIO, clock div:1
[11:00:27.401] load:0x3fff0030,len:1284
[11:00:27.401] load:0x40078000,len:12836
[11:00:27.401] load:0x40080400,len:3032
[11:00:27.401] entry 0x400805e4
[11:00:27.562] Wakeup was not caused by deep sleep: 0
[11:00:27.589] sys.alarm:0
[11:00:27.591] gps_start:1
[11:00:27.591] gps_count:0
[11:00:27.591] TDC:1200000
[11:00:27.591] addr_gps_write:0
[11:00:27.591] BAT:4.00 V
[11:00:27.591] BAT:4.00 V
[11:00:27.591] Packet queued
[11:00:27.591] 3619: EV_JOINING
[11:00:31.254] 233218: UpLinkCounter = 0
[11:00:31.360] TX on freq: 868.5MHz LMIC.datarate: 5 LMIC.txpow: 14
[11:00:31.371] Received nack
[11:00:31.371] EV_TXSTART
[11:00:31.371] 239568: TXMODE, freq=868500000, len=23, SF=7, BW=125,
```

Use **AT+FDR** command to reset and then use **AT+CFG** to check whether the configuration is back to normal

```
OK=4/b, 1H=0
[11:00:33.060] AT+CFG

[11:00:33.070] AT+MODEL=LGT92 ,v1.0.0
[11:00:33.071] AT+MOD=0
[11:00:33.071] AT+SMOD=1
[11:00:33.071] AT+DEUI=ff ff ff ff ff ff ff ff
[11:00:33.081] AT+APPEUI=ff ff ff ff ff ff ff ff
[11:00:33.081] AT+APPKEY=ff ff ff ff ff ff ff ff ff ff ff ff ff ff ff ff
[11:00:33.092] AT+DADDR=2608b913
[11:00:33.092] AT+NWKSKEY=ea 59 a8 59 d2 fa 15 68 44 da 2e 7d 06 42 e2 1d
[11:00:33.101] AT+APPSKEY=c8 22 d2 b8 19 11 a4 22 80 8a 85 2a d8 15 62 1f
[11:00:33.102] AT+ADR=1
[11:00:33.102] AT+DR=0
[11:00:33.102] AT+TXP=0
[11:00:33.102] AT+TDC=1200000
[11:00:33.102] AT+FTIME=180000
[11:00:33.102] AT+LON=1
[11:00:33.102] AT+CHE=0
[11:00:33.102] AT+FRAME=0
[11:00:33.102]
[11:00:33.102] OK
[11:00:33.102]
[11:00:36.420] start single rx: now-rxtime: 4
[11:00:36.422] 555819: RXMODE_SINGLE, freq=868500000, SF=7, BW=125,
```

After the parameters return to normal, upgrade to the version you need again

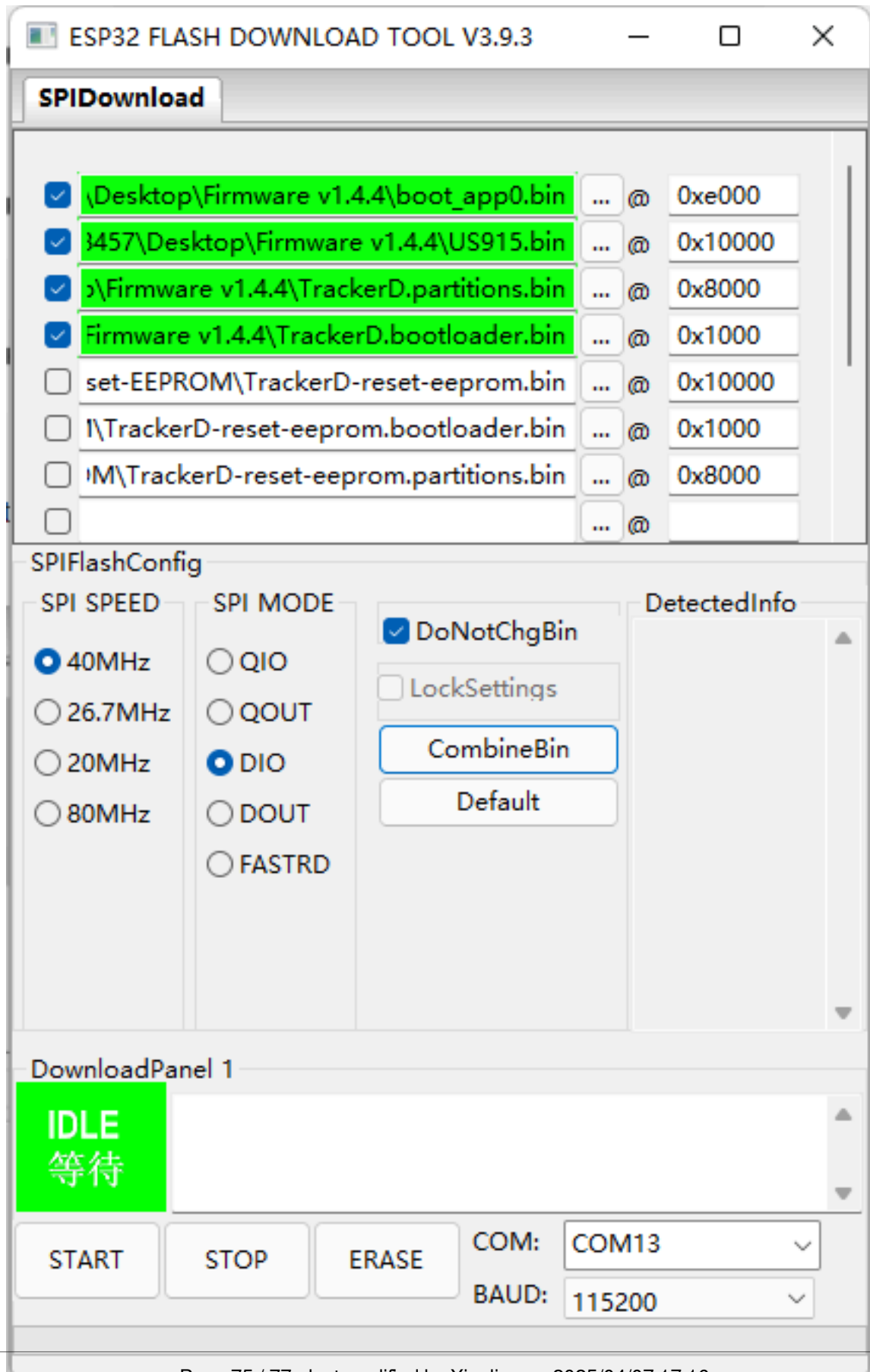

At this point, the parameters return to normal after running AT+FDR again

```
[11:02:58.155] AT+CFG
[11:02:58.165] AT+MODEL=TrackerD ,v1.4.3
[11:02:58.166] AT+DEUI=ff ff ff ff ff ff ff ff
[11:02:58.166] AT+APPEUI=ff ff ff ff ff ff ff ff
[11:02:58.176] AT+APPKEY=ff ff ff ff ff ff ff ff ff ff ff ff ff ff ff ff
[11:02:58.176] AT+DADDR=2608baec
[11:02:58.176] AT+NWKSKEY=fa 71 c6 da 68 76 6a 68 09 1d 24 50 4e af 29 a9
[11:02:58.186] AT+APPSKEY=28 6e 1e 76 2e 96 d6 5d d7 84 87 e7 5e e8 2d 9a
[11:02:58.196] AT+ADR=1
[11:02:58.196] AT+DR=5
[11:02:58.196] AT+TXP=1
[11:02:58.196] AT+SMOD=1,0,0
[11:02:58.196] AT+TDC=1200000
[11:02:58.196] AT+MTDC=1280
[11:02:58.196] AT+ATDC=131073
[11:02:58.206] AT+FTIME=180000
[11:02:58.206] AT+INTWK=0
[11:02:58.206] AT+LON=32
[11:02:58.206] AT+CHE=0
[11:02:58.206] AT+NMEA353=0
[11:02:58.206] AT+NMEA886=0
[11:02:58.206] AT+CFM=0
[11:02:58.206] AT+PNACKMD=0
[11:02:58.206] AT+PDOP=7.00
[11:02:58.206] AT+DWELLT=0
[11:02:58.217] AT+SHOWID=0
```

8.7 If you encounter the following problems, please upgrade to the latest version

1. Press and hold the red button (more than 5 seconds), and the device and server do not respond.
2. Send some commands through the serial port to prompt an error (Example: AT+SMOD=1,0,1)

8.8 Why when using some serial consoles, only inputting the first string port console will return "error"?

Need to enter the entire command at once, not a single character.
User can open a command window or copy the entire command to the serial console.

8.9 When the device is connected to the serial port, it cannot send Uplink, the light color is abnormal, and it does not respond to commands.

ESP32 hardware is affected by the flow control of the serial port control program, which causes abnormal phenomena.

Please do not select flow control when using the serial port tool.

Please refer to this link to use the serial port tool

<http://wiki.dragino.com/xwiki/bin/view/Main/User%20Manual%20for%20LoRaWAN%20End%20Nodes/TrackerD/#H7.3NotesonusingdifferentserialporttoolsforTrackerD>

9. Order Info

Part Number: **TrackerD-XXX**

XXX: The default frequency band

- **EU433**: Default frequency band EU433
- **EU868**: Default frequency band EU868
- **IN865**: Default frequency band IN865
- **KR920**: Default frequency band KR920
- **AS923**: Default frequency band AS923
- **AU915**: Default frequency band AU915
- **US915**: Default frequency band US915

10. Packing Info

Package Includes:

- TrackerD LoRaWAN GPS/BLE Tracker x 1
- USB recharge & program cable x 1

Dimensions and Weight:

- Device Size: 85 x 48 x 15 mm
- Weight: 50g

11. Support

- Support is provided Monday to Friday, from 09:00 to 18:00 GMT+8. Due to different timezones we cannot offer live support. However, your questions will be answered as soon as possible in the before-mentioned schedule.
- Provide as much information as possible regarding your enquiry (product models, accurately describe your problem and steps to replicate it etc) and send a mail to support@dragino.com.

12. Reference

- [Firmware in Bin format](#)
- [Source Code](#)
- [Hardware Source](#)